

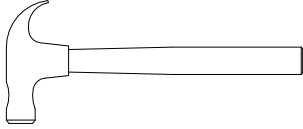

Tools Needed:

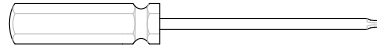

2 lbs Hammer



T-20 Torx Driver



T-27 Torx Bit
(2.75" or longer)

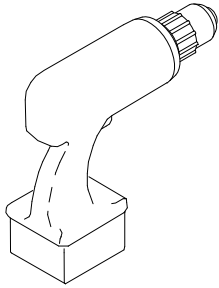

Power Driver



Small Flathead
Screwdriver



Safety Glasses

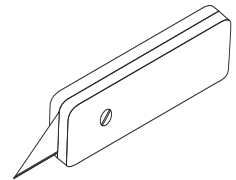

Utility Knife

Materials Identification and Segregation:

Where possible, plastic components are marked with recycling codes. Use these codes to identify material type for recycling. Non marked components should be treated as mixed plastic. Ferrous metals can be identified using a small magnet for recycling. Non-ferrous metals should be separated and recycled separately.

Disassembly Steps:

1

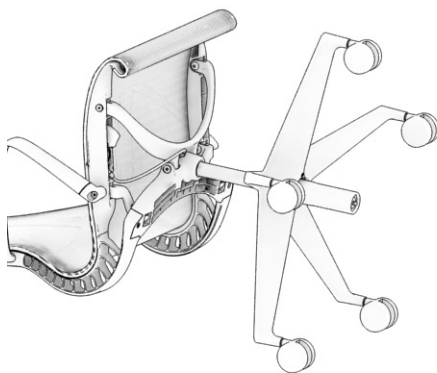

1.1. Lay chair on back.

2

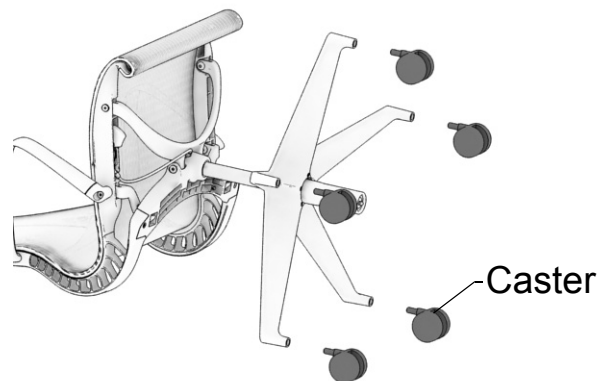

2.1. Grasp and pull to remove Casters from the Base.

HermanMiller

© 2010 Herman Miller, Inc. Zeeland, Michigan. Printed in the U.S.A.
© HermanMiller, Action Office, Mirra and Setu are among the registered trademarks of Herman Miller, Inc. Part no. 1b5vn8 rev A.
Vivo® is among the trademarks of Herman Miller, Inc.

Illustrations and specifications are based on the latest product information available at the time of publication.
The right is reserved to make changes in design and specifications at any time, without notice, and also to discontinue products.

3

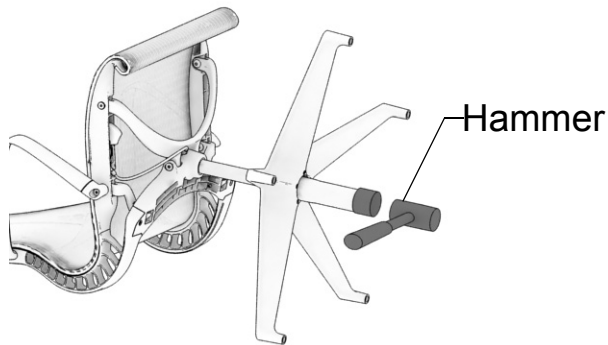

3.1. Hold Base legs firmly and strike the bottom of cylinder with a 2 pound hammer until Base comes loose.

4

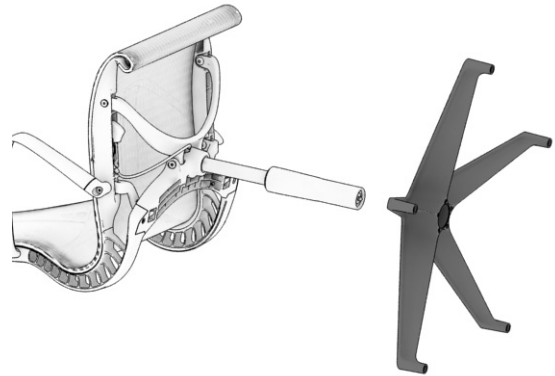

4.1. Remove Base.

5

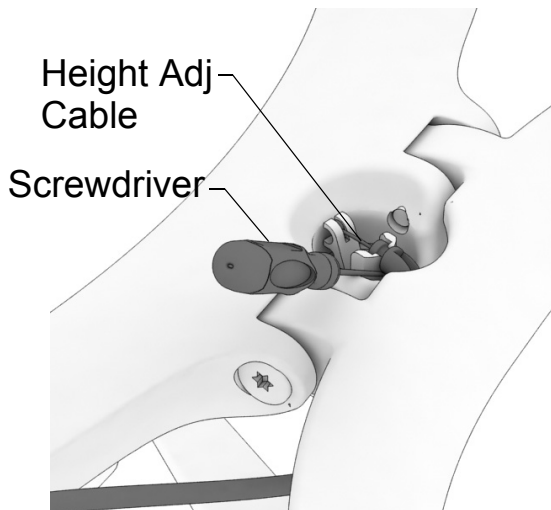

5.1. Use small Flathead Screwdriver to disengage black plastic connector of Height Adjustment Cable from top of Cylinder.

6

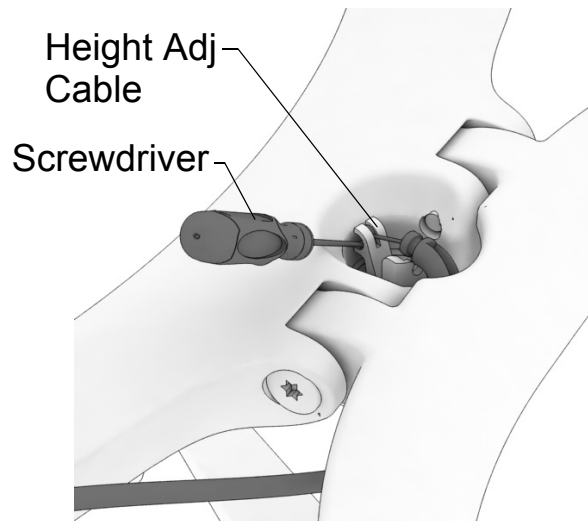

6.1. Use small Flathead Screwdriver to disengage ball of Height Adjustment Cable from top of Cylinder.

HermanMiller

© 2010 Herman Miller, Inc. Zeeland, Michigan. Printed in the U.S.A.
© Herman Miller, Action Office, Mirra and Setu are among the registered trademarks of Herman Miller, Inc. Part no. 1b5vn8 rev A.
Vivo® is among the trademarks of Herman Miller, Inc.

Illustrations and specifications are based on the latest product information available at the time of publication.
The right is reserved to make changes in design and specifications at any time, without notice, and also to discontinue products.

7

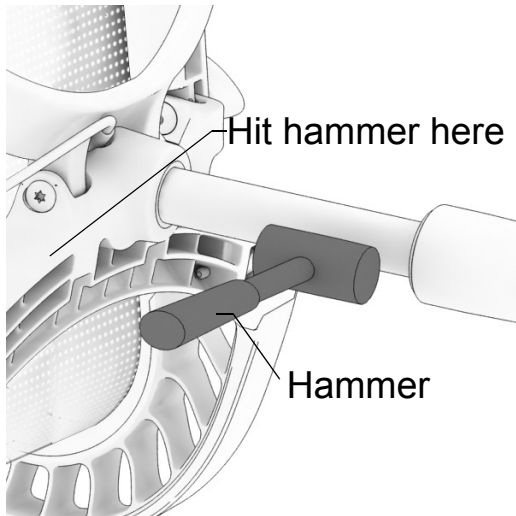

7.1. Place one hand on can of Cylinder and hit the bottom of the chair with hammer until Cylinder separates from chair.

8

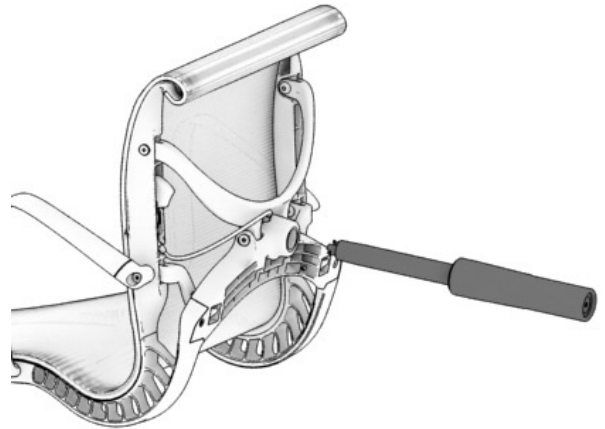

8.1. Remove Cylinder.

9

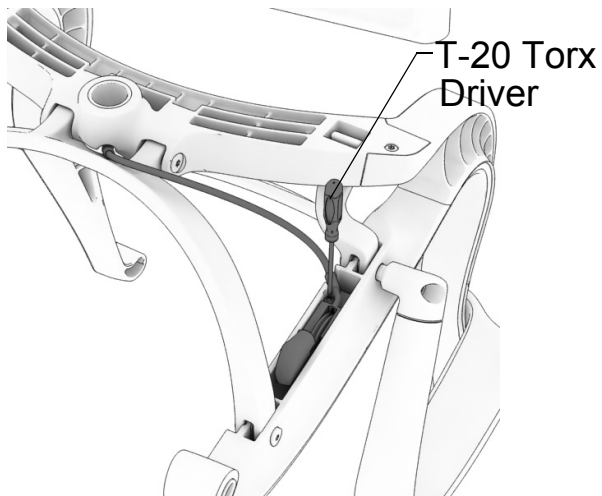

9.1. Use a T-20 Torx Driver to remove screws.

10



10.1. Remove Height Adjustment Assembly

HermanMiller

© 2010 Herman Miller, Inc. Zeeland, Michigan. Printed in the U.S.A.
© Herman Miller, Action Office, Mirra and Setu are among the registered trademarks of Herman Miller, Inc. Part no. 1b5vn8 rev A.
Vivo® is among the trademarks of Herman Miller, Inc.

Illustrations and specifications are based on the latest product information available at the time of publication.
The right is reserved to make changes in design and specifications at any time, without notice, and also to discontinue products.

11



11.1. Using a Utility Knife cut Seat Fabric in half.

12



12.1. Using a PowerDriver with a T-27 bit, remove Shoulder Bolt.



12.2. Remove Shoulder Bolts.

HermanMiller

© 2010 Herman Miller, Inc. Zeeland, Michigan. Printed in the U.S.A.
© HermanMiller, Action Office, Mirra and Setu are among the registered trademarks of Herman Miller, Inc. Part no. 1b5vn8 rev A.
Vivo® is among the trademarks of Herman Miller, Inc.

Illustrations and specifications are based on the latest product information available at the time of publication.
The right is reserved to make changes in design and specifications at any time, without notice, and also to discontinue products.

13

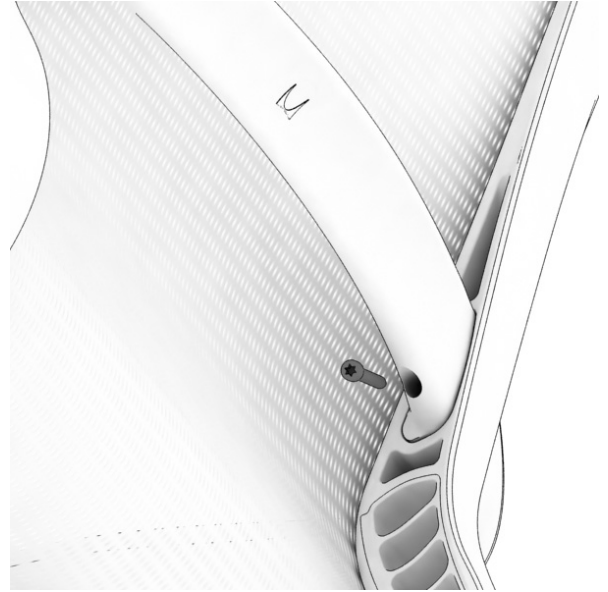
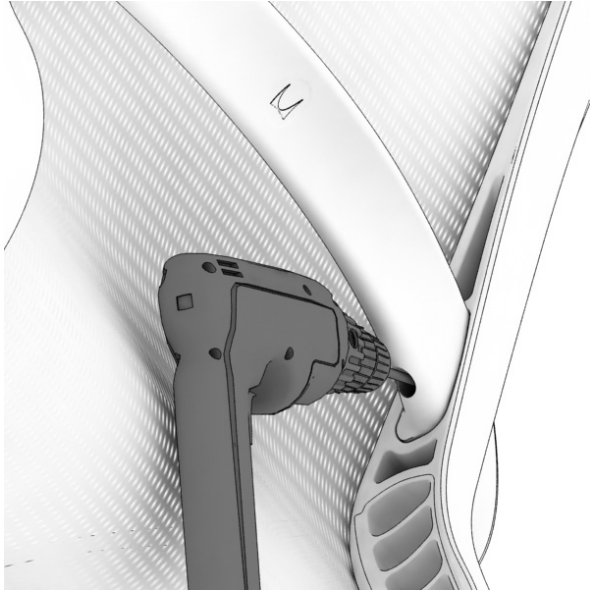

13.1. Using a PowerDriver with a T-27 bit, remove Bolt.

14

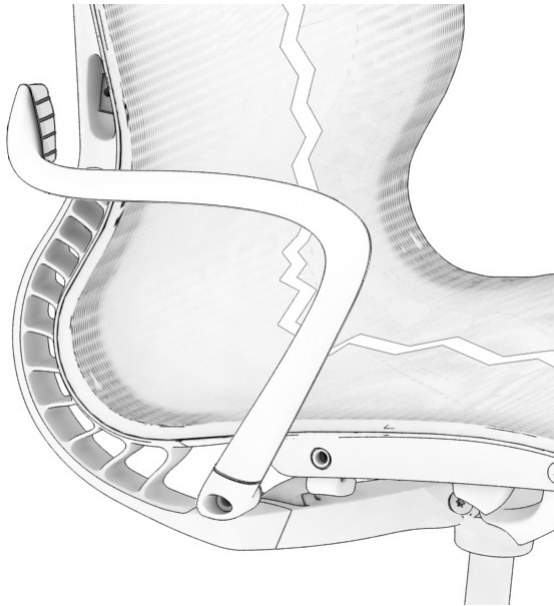

14.1. Remove Arms.

15



15.1. Remove Inner Bushing.

HermanMiller

© 2010 Herman Miller, Inc. Zeeland, Michigan. Printed in the U.S.A.
© HermanMiller, Action Office, Mirra and Setu are among the registered trademarks of Herman Miller, Inc. Part no. 1b5vn8 rev A.
Vivo® is among the trademarks of Herman Miller, Inc.

Illustrations and specifications are based on the latest product information available at the time of publication.
The right is reserved to make changes in design and specifications at any time, without notice, and also to discontinue products.

16

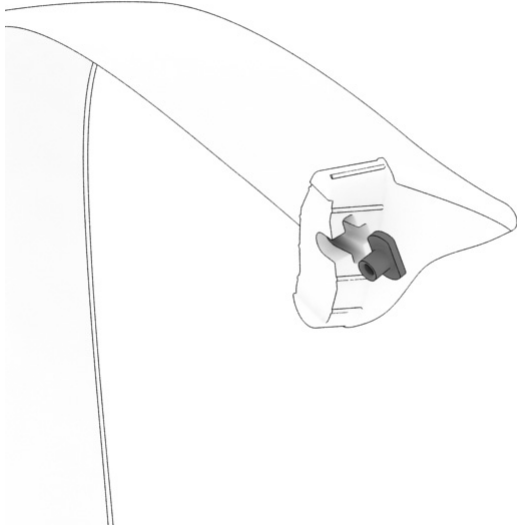

16.1. Remove T-Nut from Arm.

17



17.1. Remove No Arm Plug from opening in Beam.

18

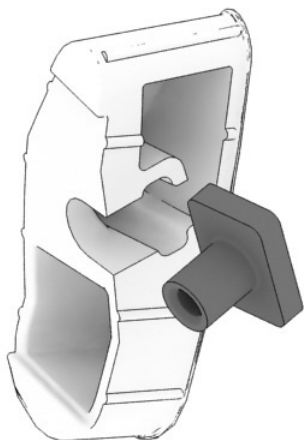

18.1. Remove T-Nut from No Arm Plug.

HermanMiller

© 2010 Herman Miller, Inc. Zeeland, Michigan. Printed in the U.S.A.
© HermanMiller, Action Office, Mirra and Setu are among the registered trademarks of Herman Miller, Inc. Part no. 1b5vn8 rev A.
Vivo® is among the trademarks of Herman Miller, Inc.

Illustrations and specifications are based on the latest product information available at the time of publication.
The right is reserved to make changes in design and specifications at any time, without notice, and also to discontinue products.

19



19.1. Using a PowerDriver with a T-27 bit, remove Shoulder Bolts.

20



20.1. Remove Inner Bushings.

HermanMiller

© 2010 Herman Miller, Inc. Zeeland, Michigan. Printed in the U.S.A.
© Herman Miller, Action Office, Mirra and Setu are among the registered trademarks of Herman Miller, Inc. Part no. 1b5vn8 rev A.
Vivo® is among the trademarks of Herman Miller, Inc.

Illustrations and specifications are based on the latest product information available at the time of publication.
The right is reserved to make changes in design and specifications at any time, without notice, and also to discontinue products.

21

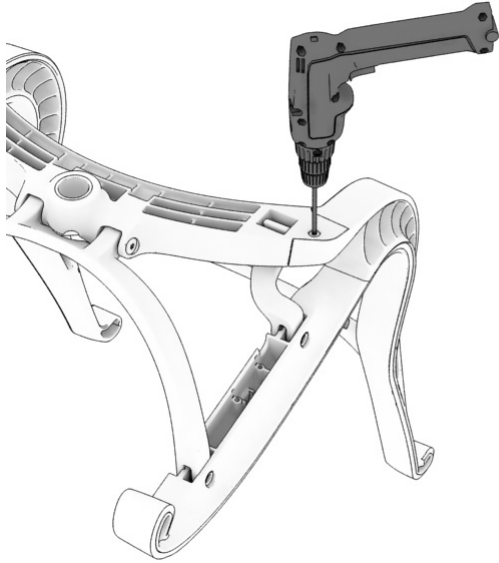

21.1. Using a PowerDrill with a T-27 bit, Remove Screw.

22

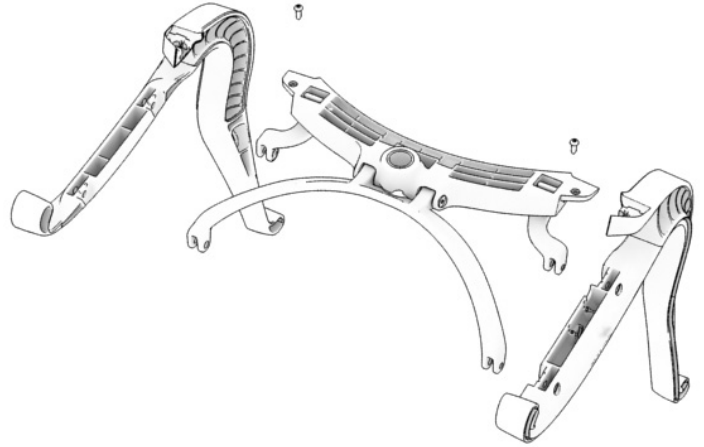

22.1. Remove Tilt Assembly from Seat Assembly.

23

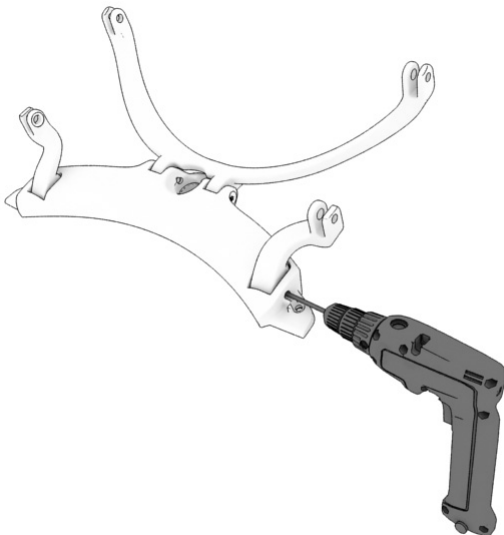

23.1. Using a PowerDrill with a T-27 bit, remove Shoulder Bolt.

24

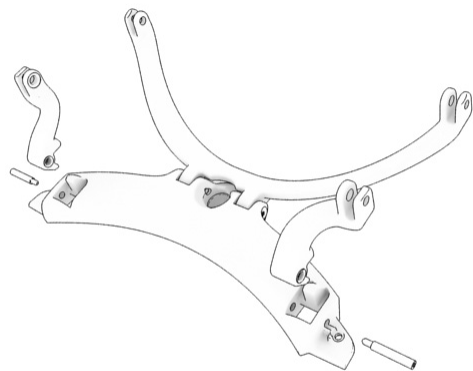

24.1. Remove Yoke.

HermanMiller

© 2010 Herman Miller, Inc. Zeeland, Michigan. Printed in the U.S.A.
© Herman Miller, Action Office, Mirra and Setu are among the registered trademarks of Herman Miller, Inc. Part no. 1b5vn8 rev A.
Vivo® is among the trademarks of Herman Miller, Inc.

Illustrations and specifications are based on the latest product information available at the time of publication.
The right is reserved to make changes in design and specifications at any time, without notice, and also to discontinue products.

25

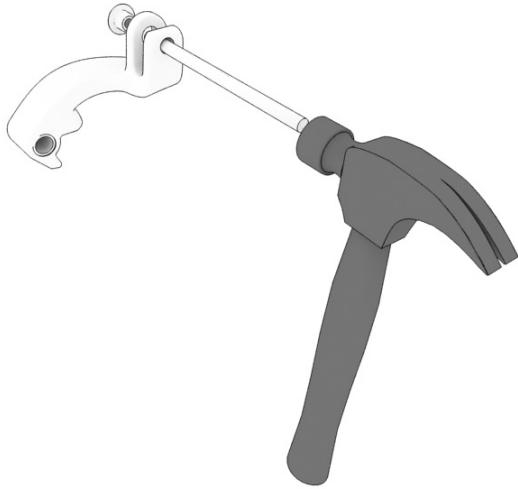

25.1. Using a small shaft or screw driver. Remove pressed T-Nut from both Yokes.

26



26.1. Pull Fabric out of groove in Seat frames to remove. Remove metal clips from fabric.

27

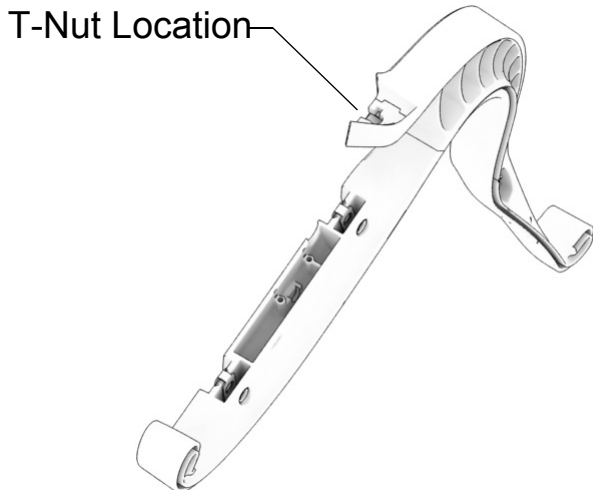

27.1. Remove T-Nuts from Seat frame.