

# HermanMiller

## Renew™ Link Installation

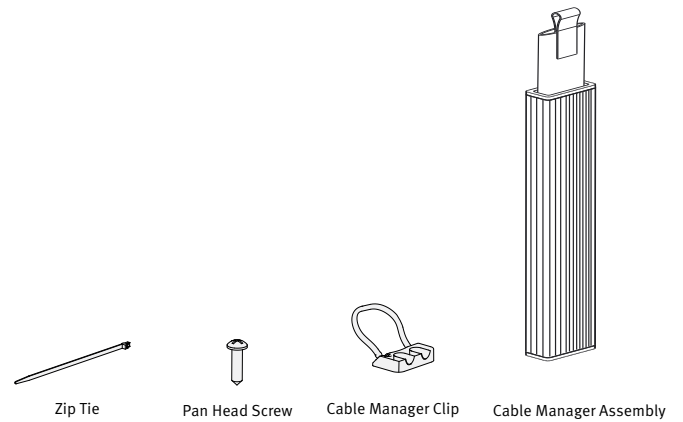

### Parts Included



## How to Install Cable Manager Assembly

### Tools Required



Illustrations and specifications are based on the latest product information available at the time of publication.

The right is reserved to make changes in design and specifications at any time, without notice, and also to discontinue products.

**Notice:** Some of the parts have been wrapped to protect them during shipping. Remove the plastic wrap before assembling the table.

Assemble products on a protective surface.  
For Nevi, Motia and Renew table

### Step 1

1.1 Feed the cables through the sleeve and through the back of the extrusion. Refer step 2.2

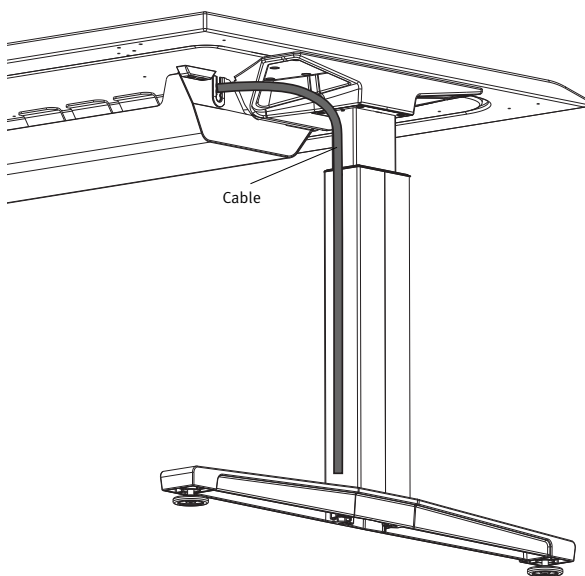

### Step 2

2.1 Align the extrusion assembly on the lowest section of the height adjustable leg allowing the magnets to attach to the leg. The product can be installed on whichever side of the leg is preferred.

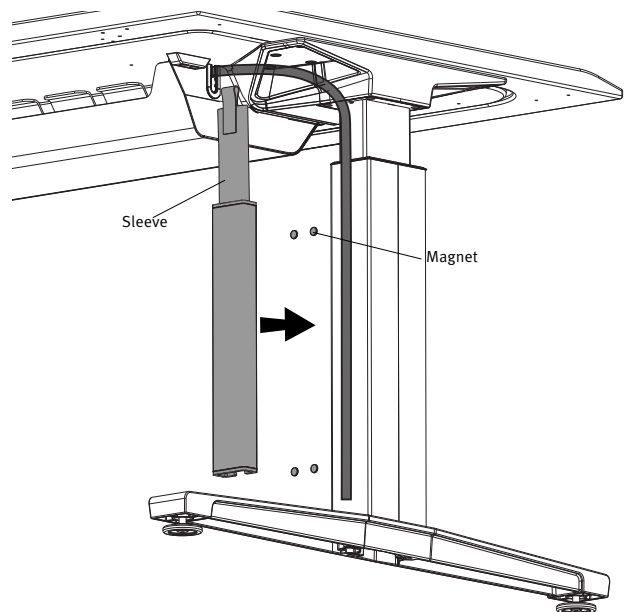

2.2 Cable fed into cable manger assembly and attached to the leg

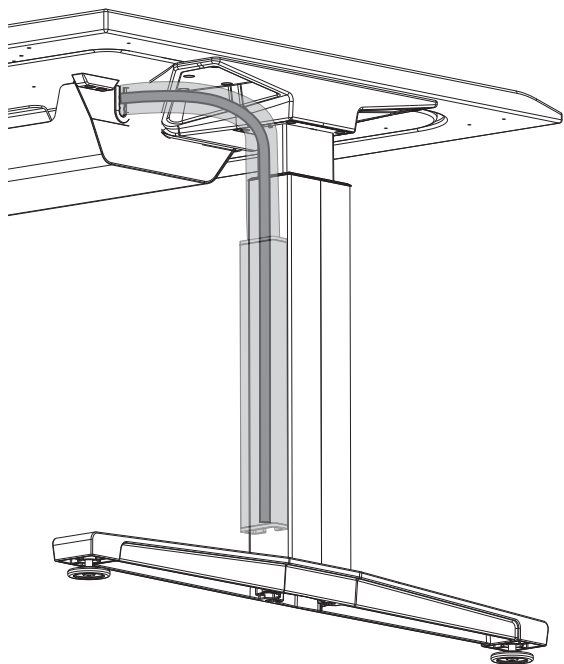

### Step 3

#### DU15B Only

3.1 Put the zip tie through the upper loops of the sleeve and tighten around the cord, push the zip tied connection up against the grommet of the High Density Trough.

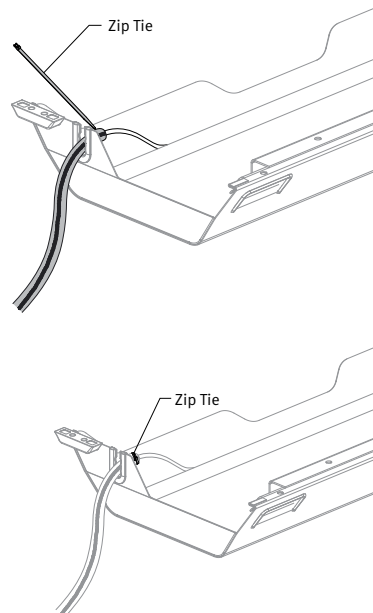

### Step 4

#### DU15S Only

4.1 Pre-drill holes for the worksurface clip using the 1/8" drill bit. Attach the work surface clip using the included screws.

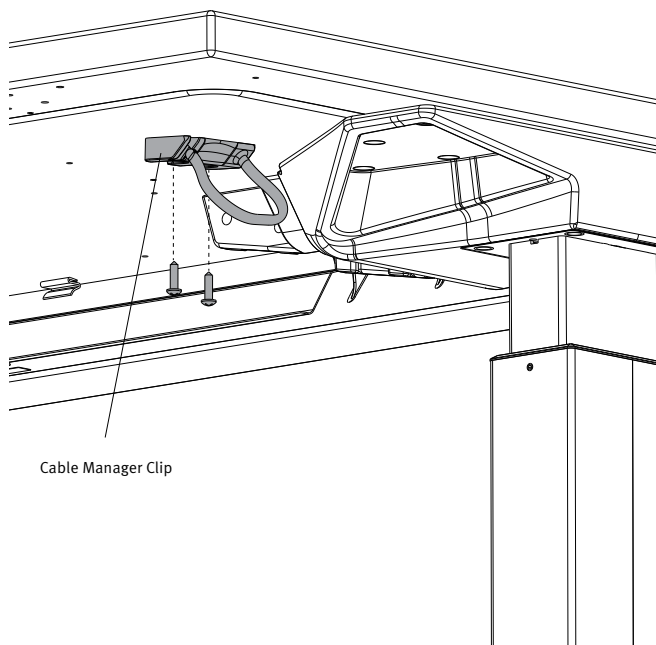

4.2 Loop the cable manager to the work surface clip.

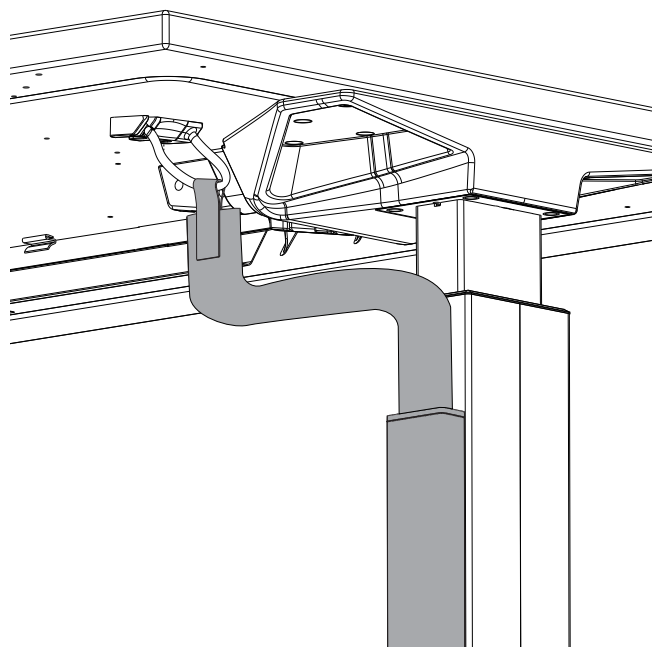

For more information about our products and services please visit us at [hermanmiller.com](http://hermanmiller.com) or call (800) 851 1196.

©2019 Herman Miller, Inc., Zeeland, Michigan Printed in U.S.A. Part No. 1BSB01