



Table of Contents

Mirra 2 [®] Seat Replacement.....	2
Mirra 2 [®] Back Replacement	9
Mirra 2 [®] Lumbar Stem Replacement.....	15
Mirra 2 [®] Lumbar Bow Replacement	23
Mirra 2 [®] Spine Replacement.....	25
Mirra 2 [®] Front Tilt Cover Replacement.....	33
Mirra 2 [®] Rear Tilt Cover Replacement	35
Mirra 2 [®] Bottom Tilt Cover Replacement	36
Mirra 2 [®] Tilt Replacement.....	38
Mirra 2 [®] Arm Replacement	59
Mirra 2 [®] Arm Pad Replacement	67
Mirra 2 [®] Arm Pad Plate Replacement.....	69
Mirra 2 [®] Seat Depth Mechanism Replacement	74
Mirra 2 [®] Base Replacement	81
Mirra 2 [®] Cylinder Replacement	84
Mirra 2 [®] Tilt Control Replacement	88
Mirra 2 [®] Fixed Lumbar Bow Replacement.....	96
Mirra 2 [®] Arm Casting Replacement.....	102
Mirra 2 [®] Sleeve Bearing Replacement/Hip Pivot Retainer/ Hip Pivot Bushing/ Arm Stem Sleeve.....	112
Mirra 2 [®] Arm Stem Assembly Replacement.....	126
Mirra 2 [®] Front Link Assembly Replacement.....	138
Mirra 2 [®] Footring Replacement	147



Parts Included:



Seat Assembly

Tools Required:



Small Flat Head
Screw Driver

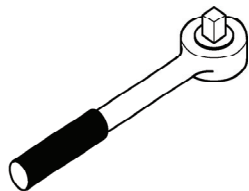

Ratchet Wrench



T40 Torx Bit



T25 Torx Bit

Steps:

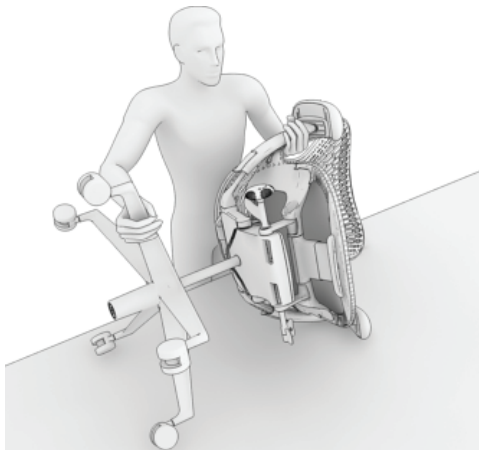

1. Lay chair on its side.

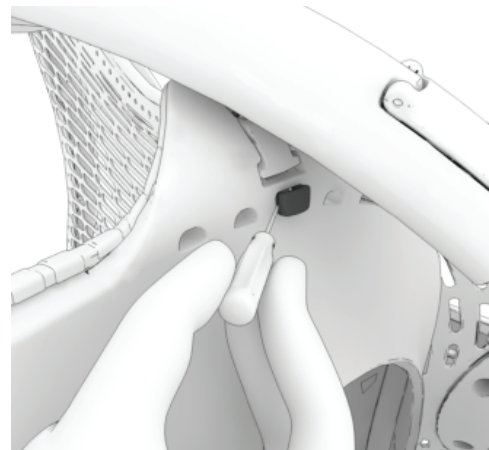

2. Remove the D-Plug from the retainer hole using the small screw driver. Repeat for the opposite side.

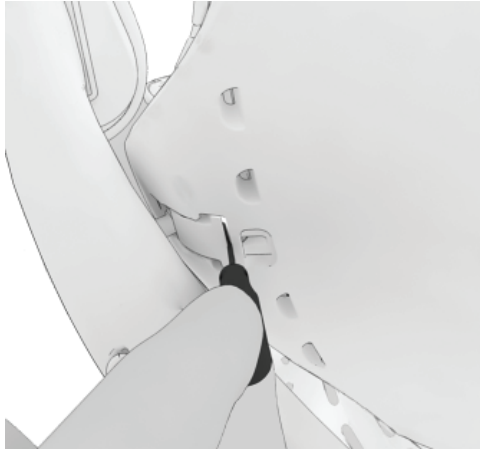

3. Slide the flat head screw driver into the slot and depress the spring clip.

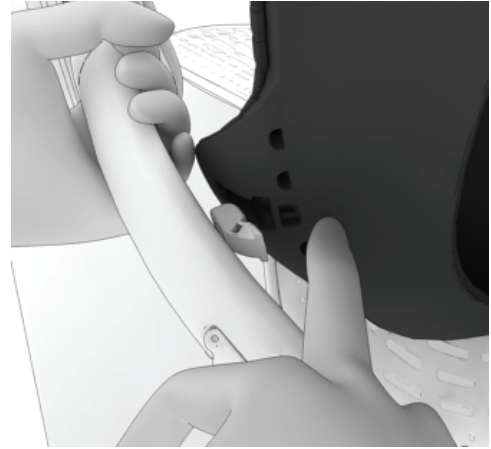

4. Lift up on the seat while depressing the spring clip. Repeat for the opposite side.

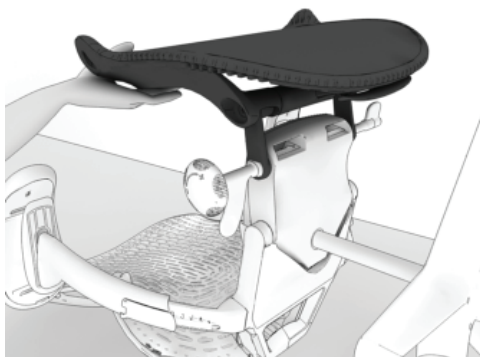

5. Tip seat assembly forward.

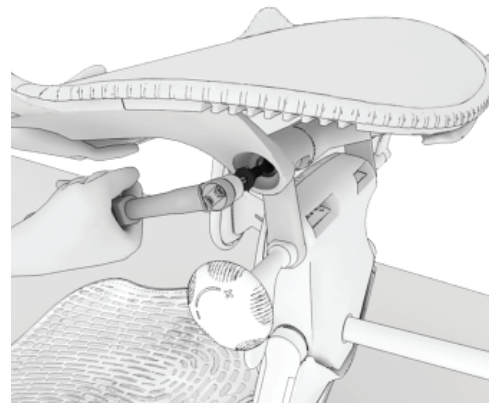

6. Using T40 torx bit remove the retainer bolt. Repeat for the other side.

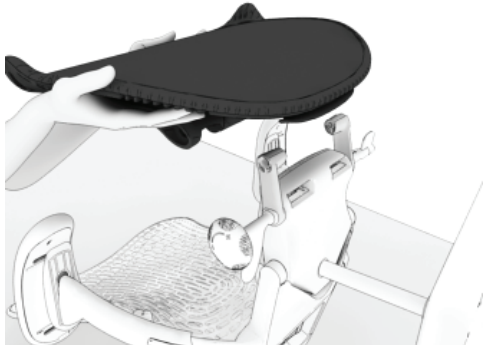

7. Remove the seat from chair.

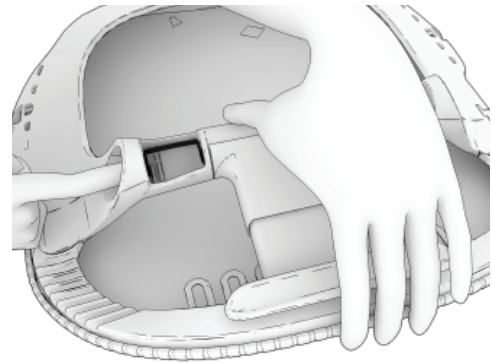

8. While compressing the seat depth mechanism push the bushing insert from the outside to remove.

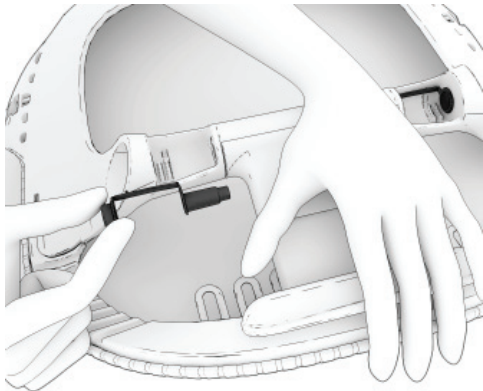

9. Carefully slide the seat link bushing from the seat depth mechanism and set aside. Repeat for opposite side.



10. Using a T27 torx bit remove the two screws from the seat depth mechanism.

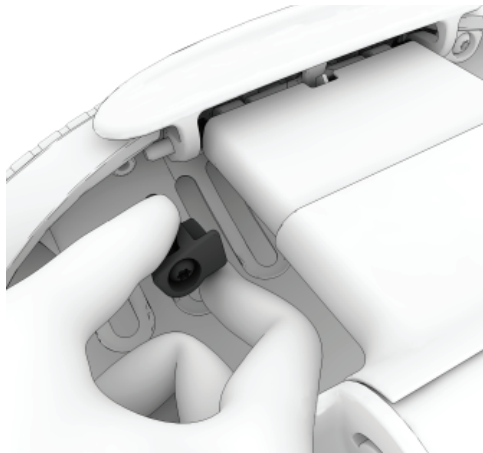

11. Remove the retainer caps.

Note: Caps are handed so note their original orientation before removing.



12. Remove seat depth mechanism from seat.

Re-assembly Steps:

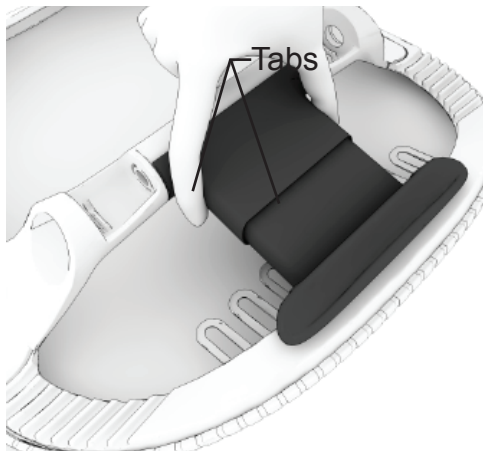

13. Locate the front edge first. Make sure the 2 tabs engage in the notches at the seat front.

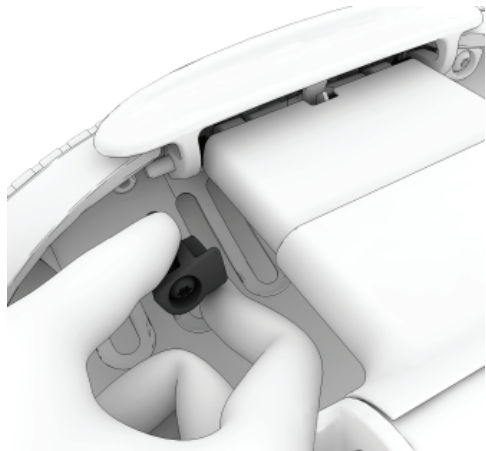

14. Install the retainer caps based on their original position and orientations.



15. Using T-27 torx bit install the two screws. Torque to 28 in/lbs.

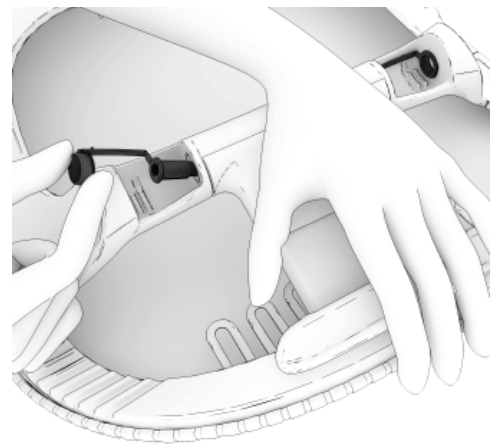

16. Position the back of the seat depth mechanism and compress to install the seat link bushings.

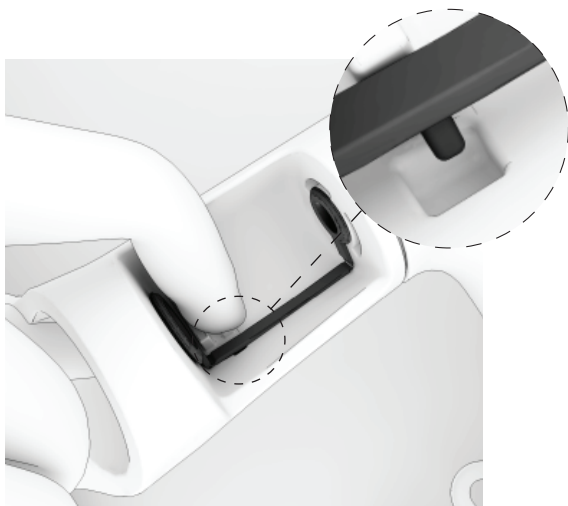

17. Make sure the tab on the bushing engages with the slot on seat frame.

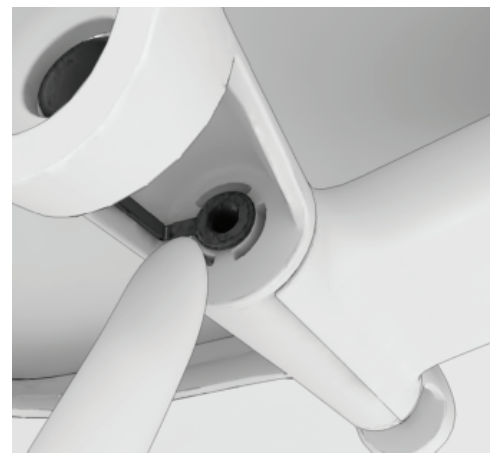

Note: Make sure the bushings are locked into the seat depth mechanism.

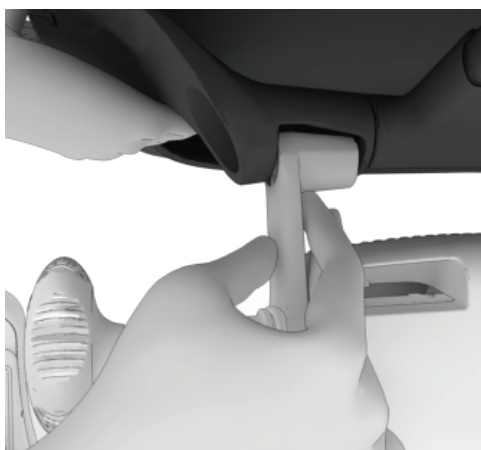

18. Rotate the seat down over the front links.

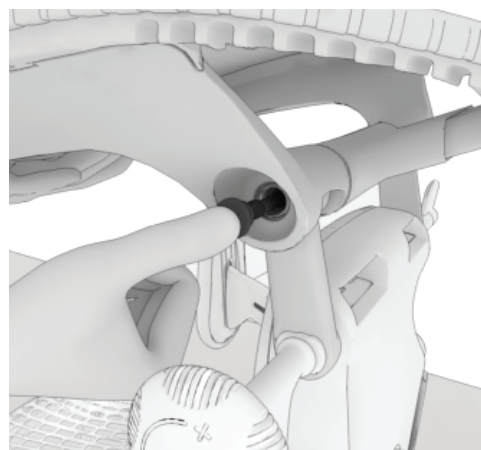

19. Install the bolts on both sides.

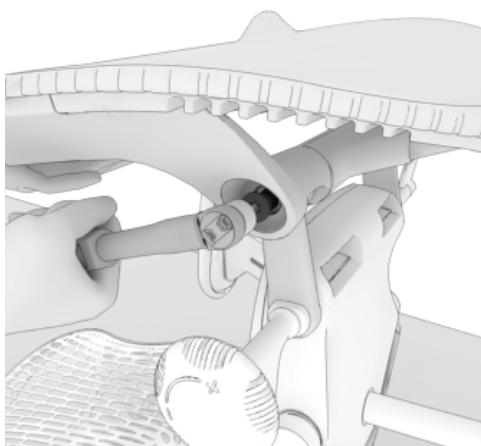

20. Using T40 torx bit, tighten the bolts to 300 in/lbs torque.

Caution: Do not over torque.

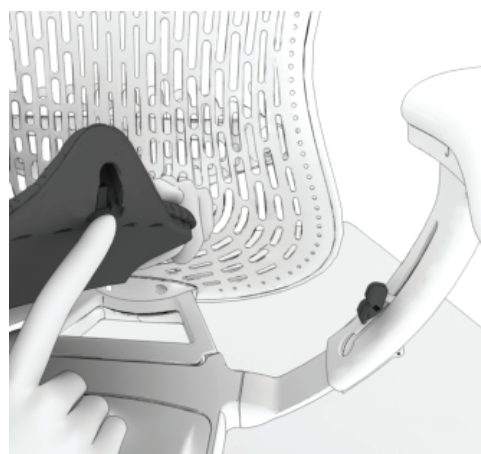

21. Rotate the seat to the end use position sliding the pivot bushing into the keyed opening in the seat.

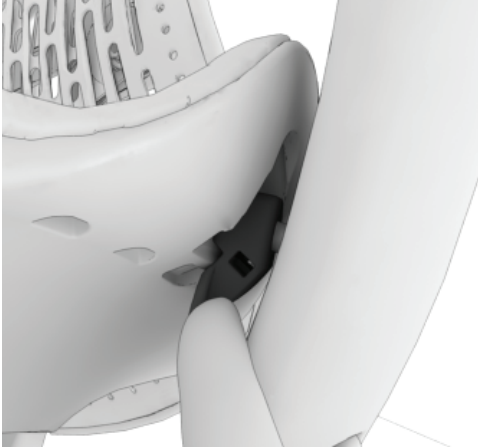

24. Push down until it snaps.
Repeat for the other side.

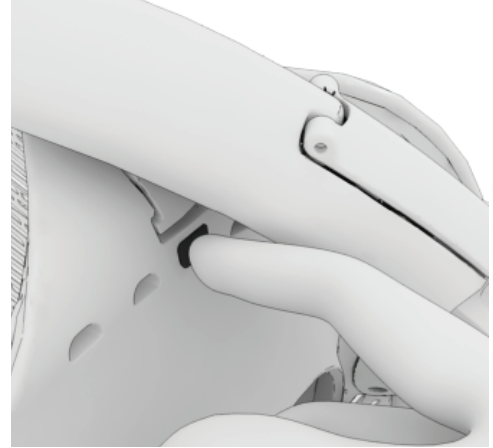

25. Instal the D-Clips into
seat. Repeat for the other
side.

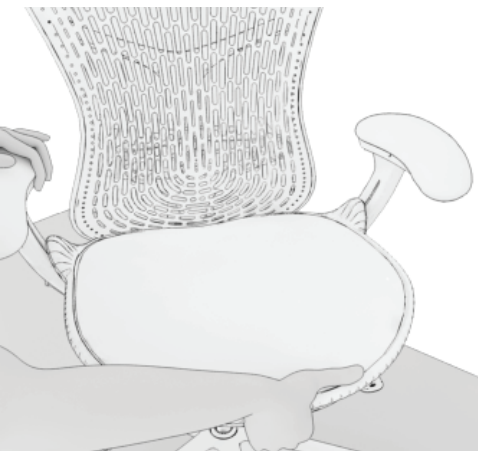

26. Check for proper function.



Parts Included:

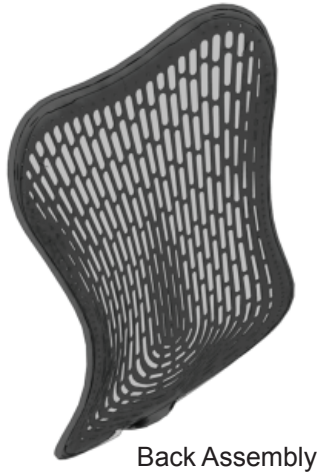

Back Assembly

Tools Required:



Small Flat Head
Screw Driver

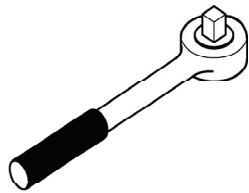

Ratchet Wrench



T40 Torx Bit

Steps:

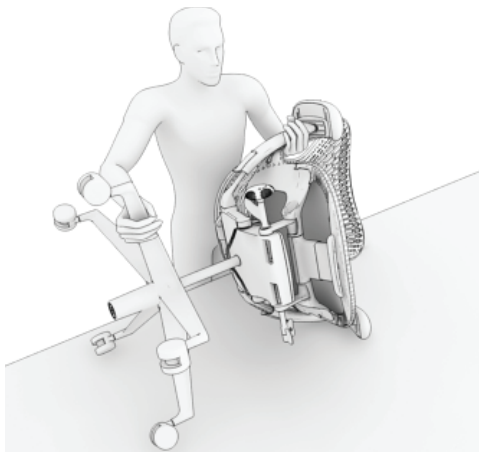

1. Lay chair on the side.

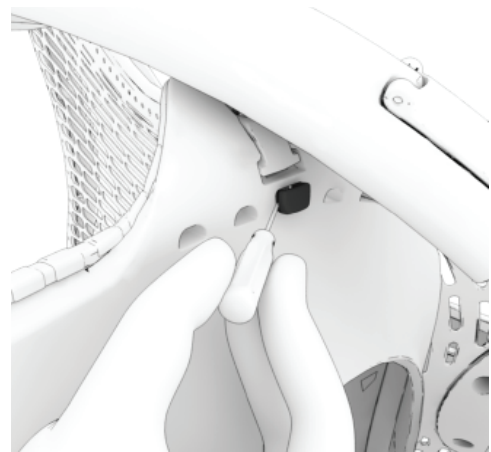

2. Remove the D-Plug from the retainer hole using the small screw driver. Repeat it for the opposite side.

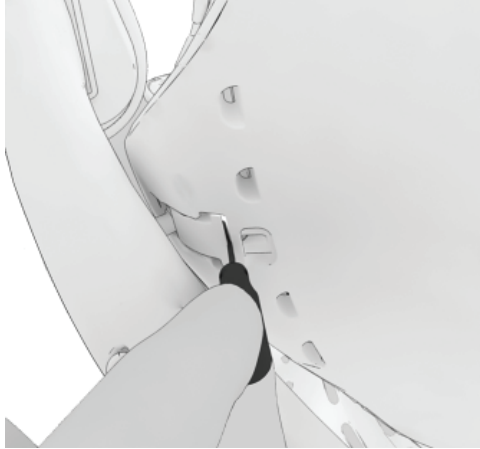

3. Slide the flat head screw driver into the slot and depress the spring clip.

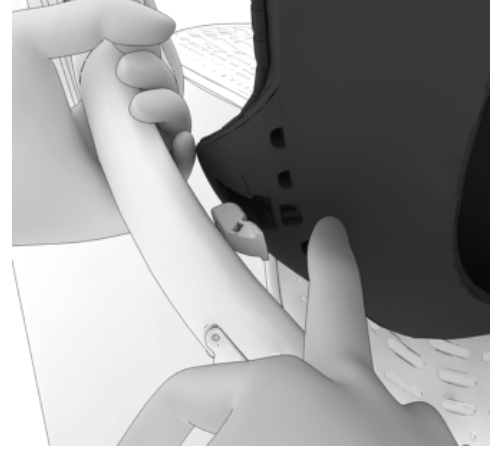

4. At the same time push the seat upward till the knob disengaged from seat. Repeat it for the other side.

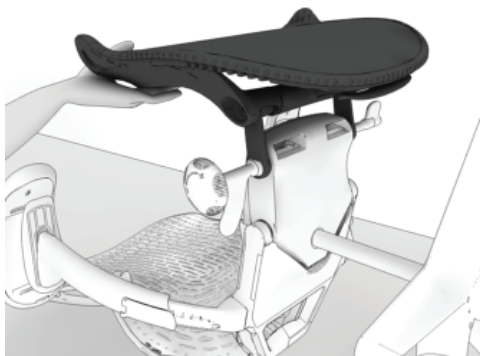

5. Make the seat loosen from the back.



6. Roll the seat forward.

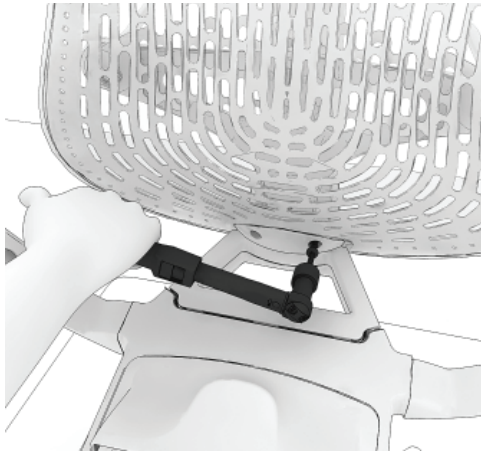

7. Using extended 2 inch long T27 torx bit remove the two screws at the lower bottom.



8. Remove the trim cover.

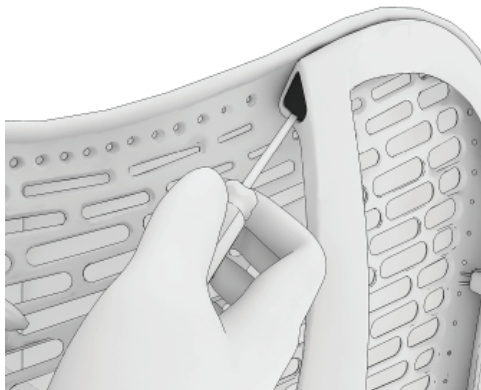

9. Using a small flat screw driver slide into the gap to remove oval shaped retainer clip.

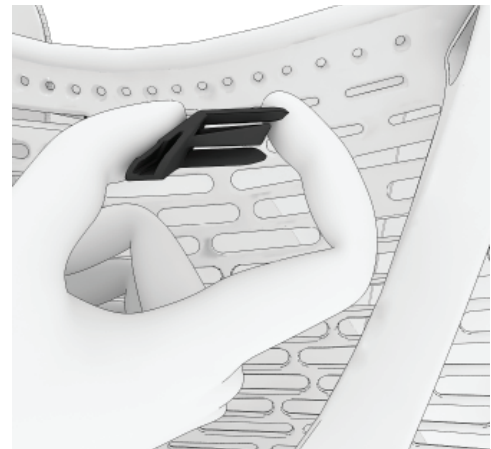

10. Remove the handed clip, Repeat for the opposite side.

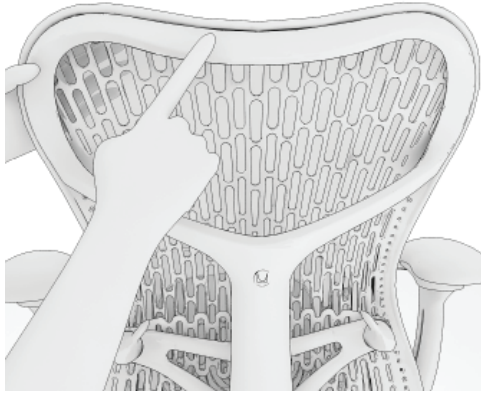

11. The back is hooked over the top of the loop.



12. Lift up on the bottom and top at the same time to completely take off the back part.

Re-assembly Steps:



13. To reinstall the back pad, ensure that each pocket has the steel tab in it.



14. Hook the top of the pad over the peg and push it down.

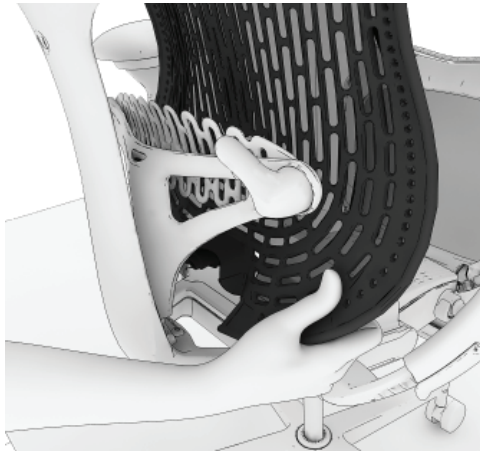

15. Flex the back around the spine and make sure the attachment point at the bottom end of the hook are in place.

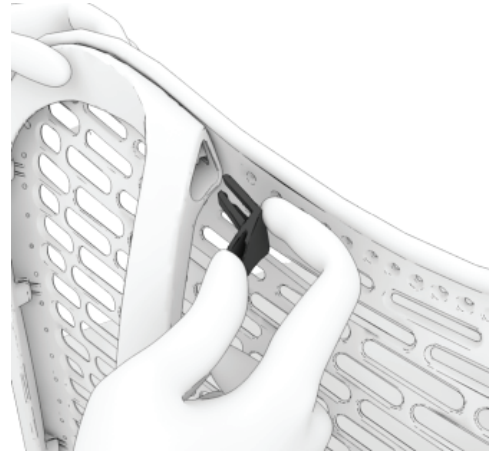

16. Reinstall the retainer clips for the upper back.

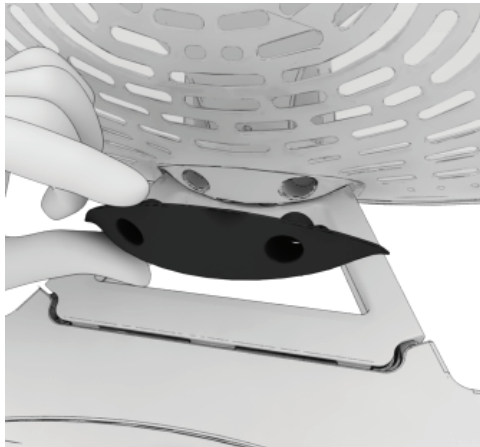

17. Reinstall the trim cover.

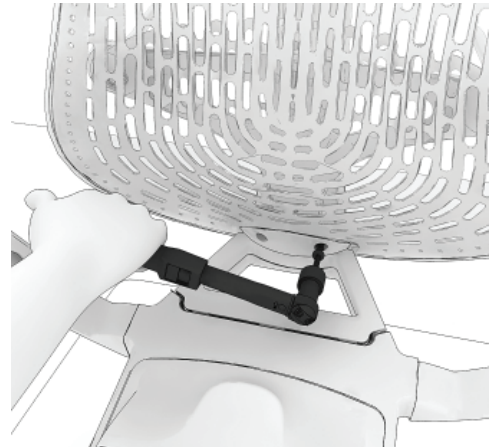

18. Reinstall the bolt using the extended T27 torx bits.

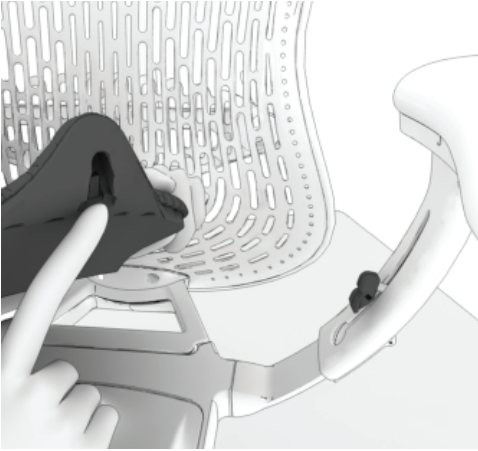

19. Rotate the seat back.
The bushing at the arm
should slide up into the
keyed opening on the seat.

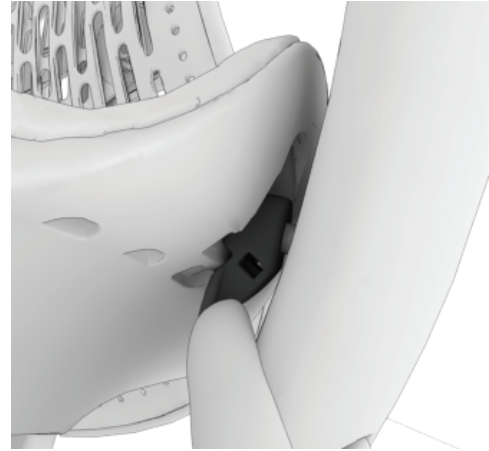

20. Slide it down until a snap.
Repeat it for the other side.

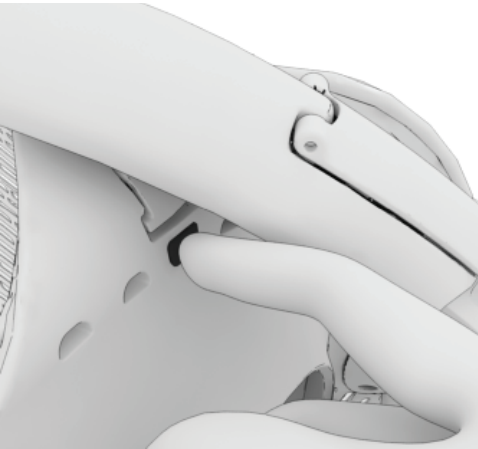

21. Instal the D-Clips into
seat. Repeat it for the other
side.

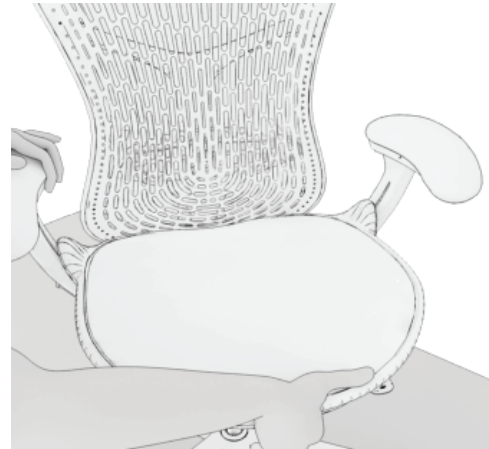

22. Check for proper function.



Parts Included:



Lumbar Stem

Tools Required:



Small Flat Head
Screw Driver

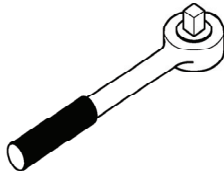

Ratchet Wrench



T40 Torx Bit

Steps:

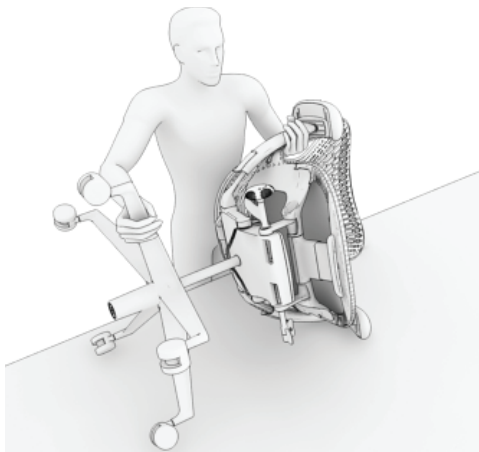

1. Lay the chair on its side.

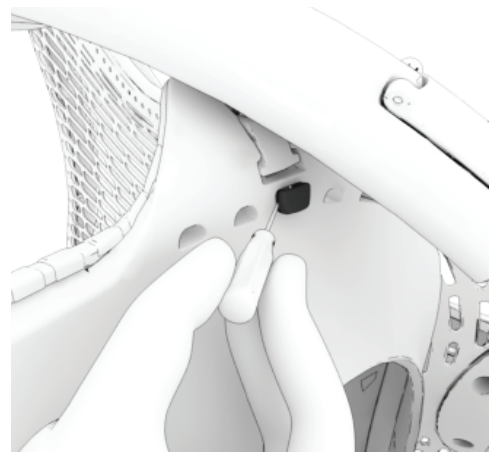

2. Remove the D-Plug from the retainer hole using the small screw driver. Repeat for the opposite side.

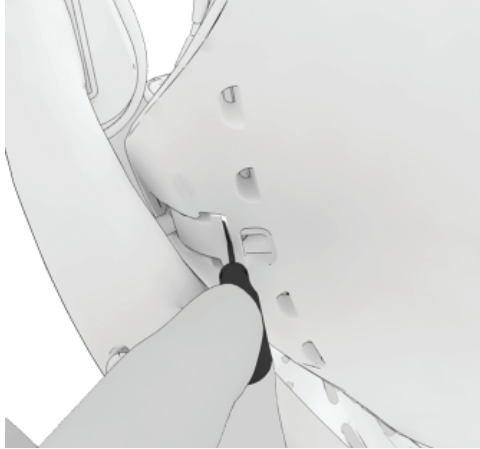

3. Slide the flat head screw driver into the slot and depress the spring clip.

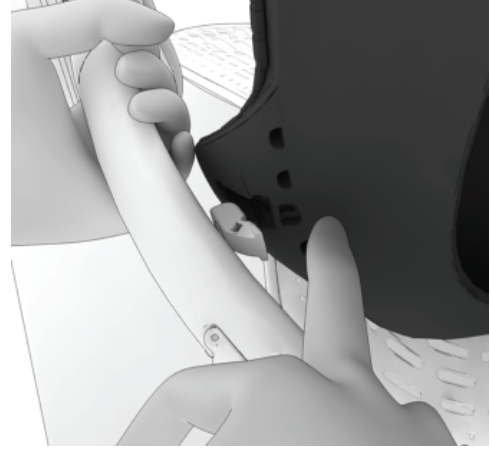

4. Lift up on the seat while depressing the spring clip. Repeat for the opposite side.



5. Stand the chair upright and roll the seat forward.

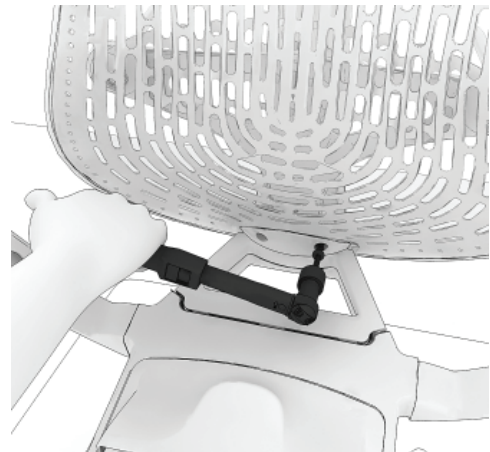

6. Use an extended 4 inch long T27 torx bit to remove the 2 screws at the bottom center of the back.

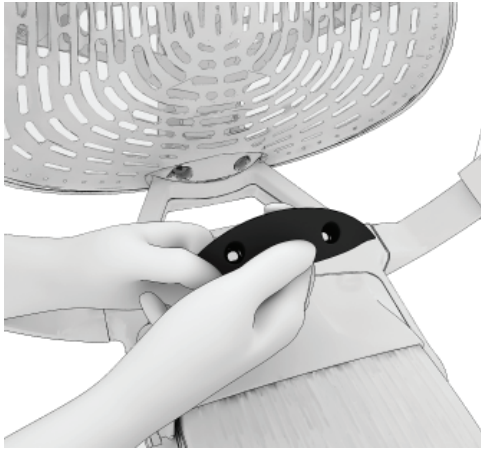

7. Remove the trim cover.

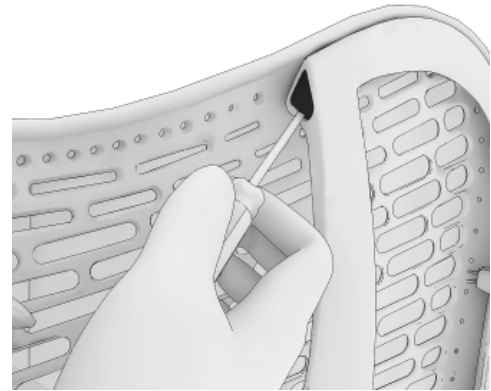

8. Slide a small flat screw driver into the gap to remove oval shaped retainer clip.

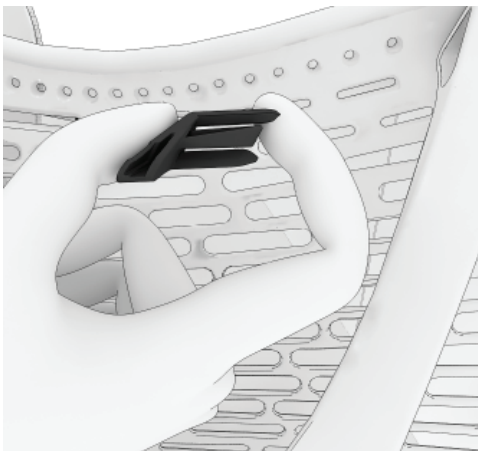

9. Remove the handed clip,
Repeat for the opposite side.



10. Lift up on the bottom and top at the same time to completely remove the back. (Note: Make sure the 4 metal teeth remain intact in the loop.)

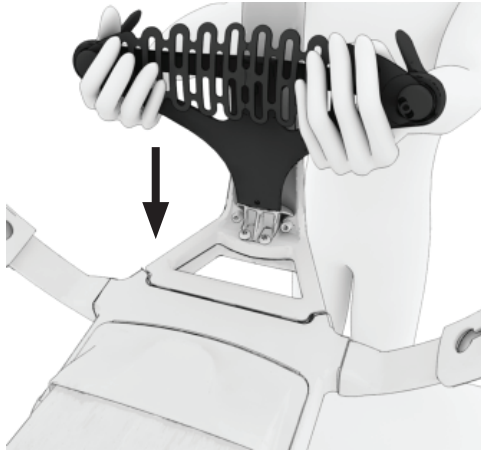

11. To disengage the lumbar bow assembly from stem, slide it all the way to the bottom.

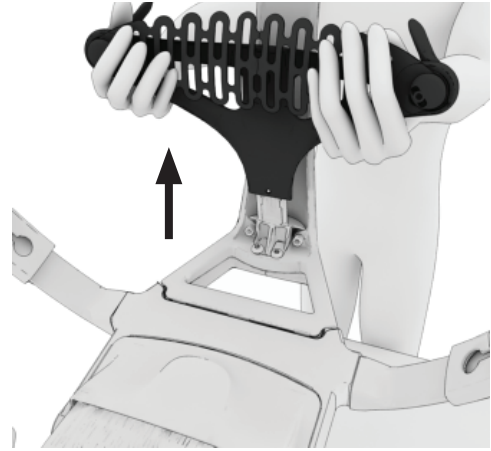

12. Jerk it up firmly until it comes off the stem.

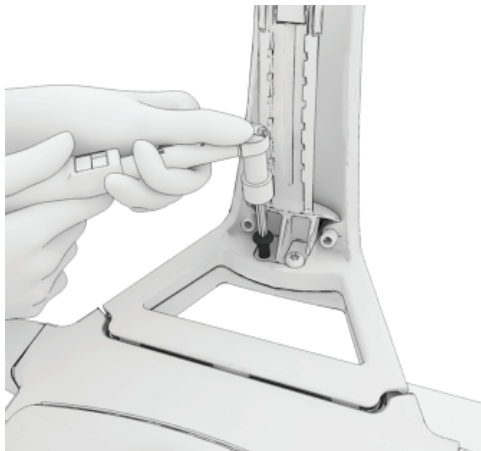

13. Using T40 torx bit remove the 2 bolts from the back yoke.



14. Remove the lumbar stem assembly.

Re-Assembly Steps:



15. Set the new lumbar stem assembly into the recess.

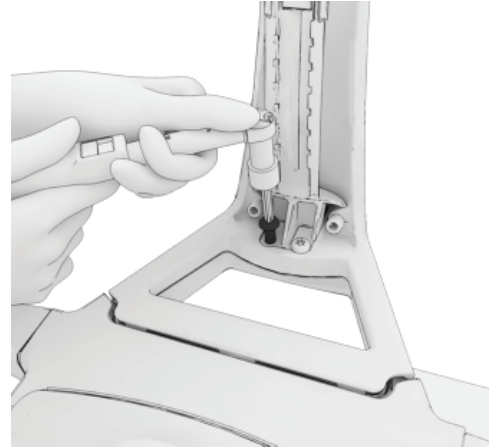

16. Using T40 torx bit reinstall the bolts. Torque to 220 in/lbs.

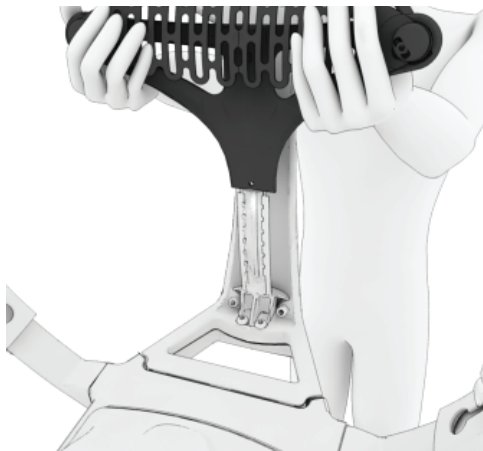

17. Place Lumbar assembly over the Lumbar post.

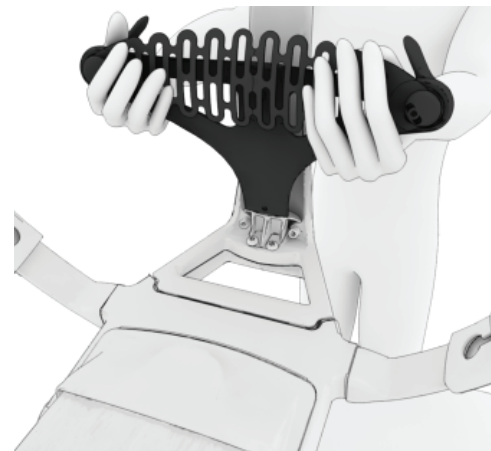

18. Push firmly down until the Lumbar snaps into position. Cycle up.



19. To reinstall the back pad, ensure that the 4 metal teeth are installed.



20. Hook the top of the pad over the teeth and push it down.

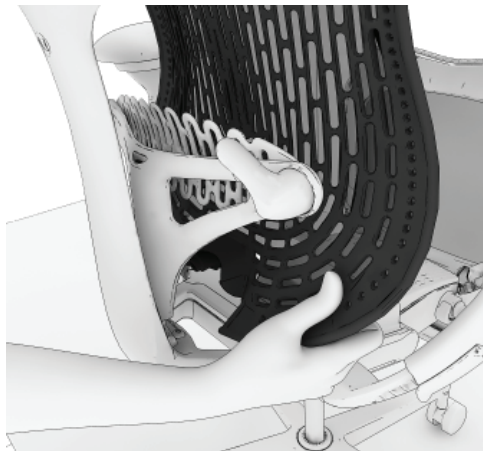

21. Flex the Back and slide around the bottom of the spine.

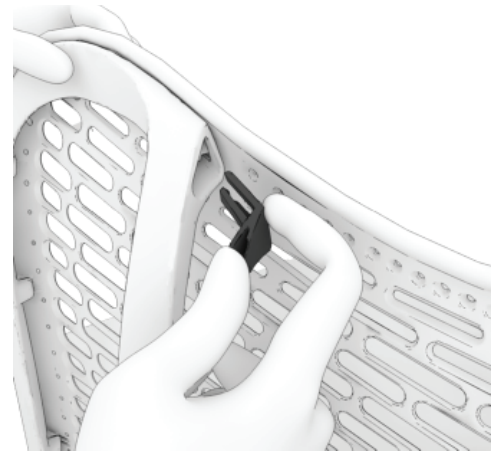

22. Reinstall the retainer clips for the upper back.

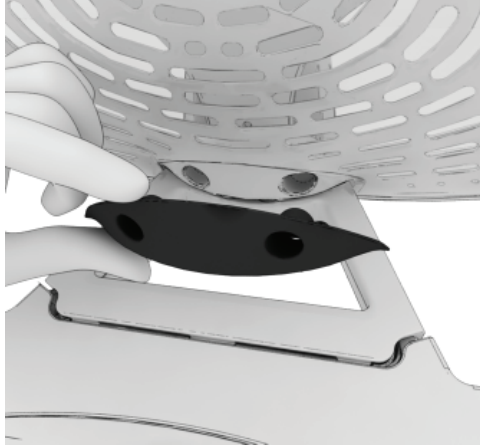

23. Reinstall the trim cover.

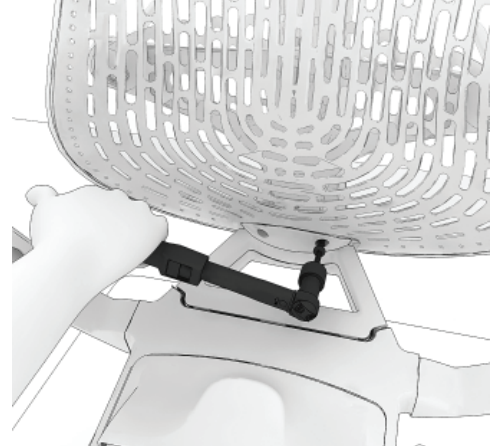

24. Tighten the bolts using the extended T27 torx bits. Torque to 70 in/lbs.

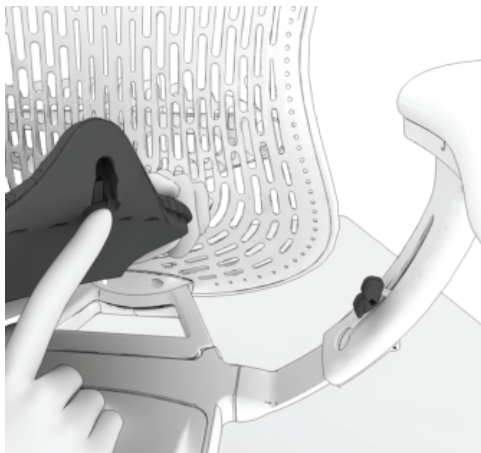

25. Rotate the seat to the end use position sliding the Pivot Bushing into the keyed opening in the seat.

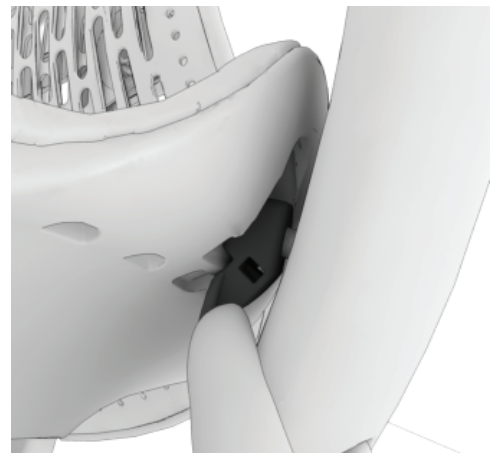

26. Push down until it snaps.

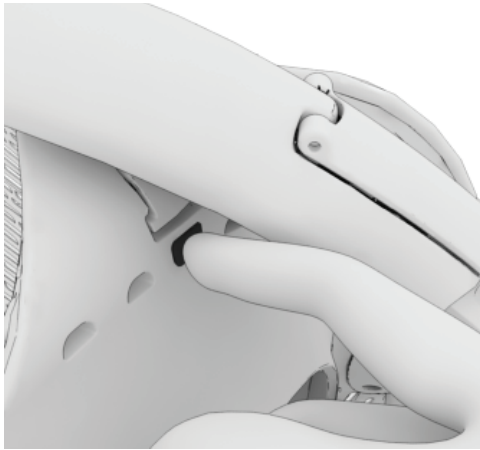

27. Re-install the D-Clips into seat. Repeat for the other side.

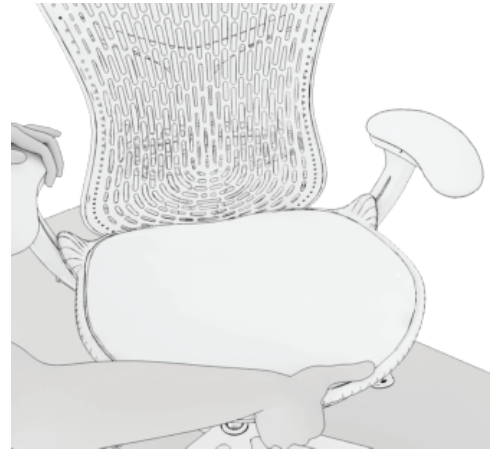

28. Check for proper function.



Parts Included:

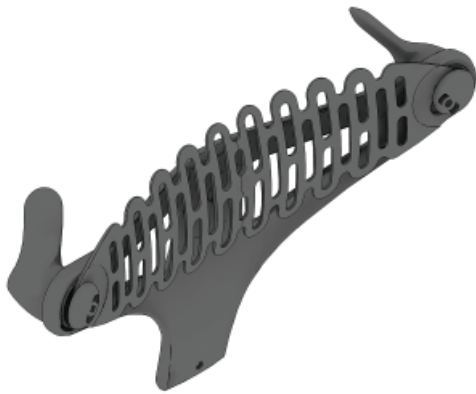

Lumbar Bow

Steps:

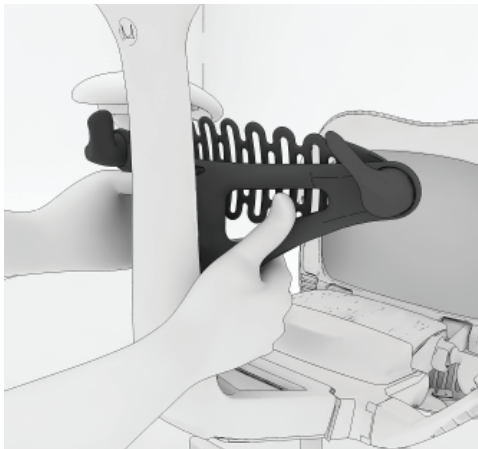

1. Slide the Lumbar to the lowest position.

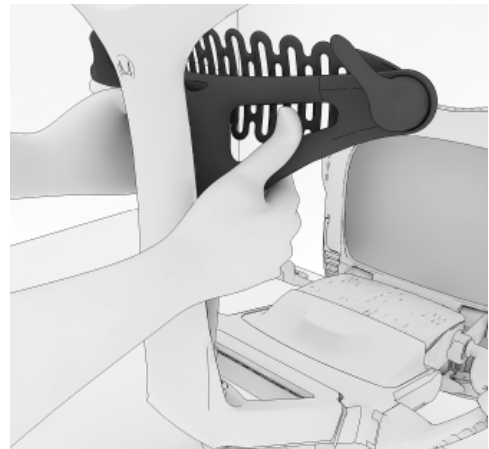

2. Pull up firmly and quickly to the top of the post to remove.

Re-Assembly Steps:

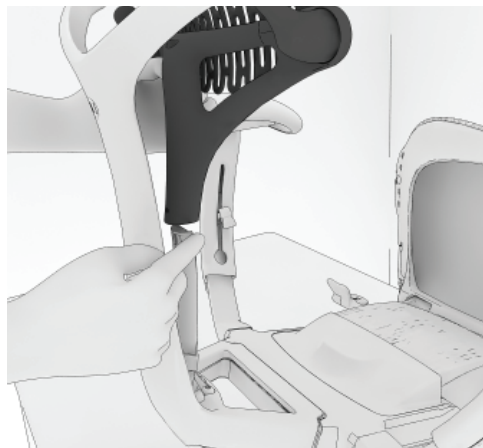

3. Place Lumbar assembly over the Lumbar post.

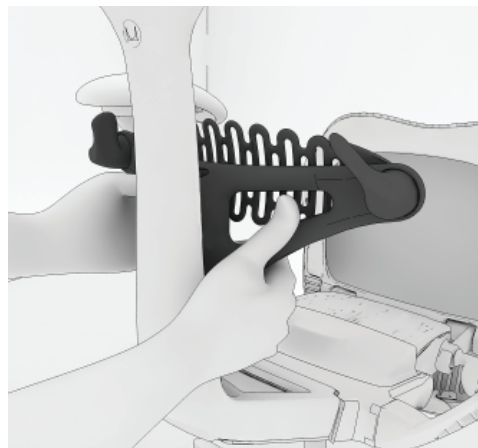

4. Push firmly down until the Lumbar snaps into position. Cycle up.



Parts Included:



Spine Assembly

Tools Required:



Small Flat Head
Screw Driver

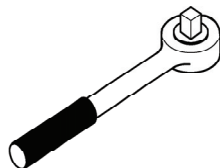

Ratchet Wrench



T27 Torx Bit

Steps:

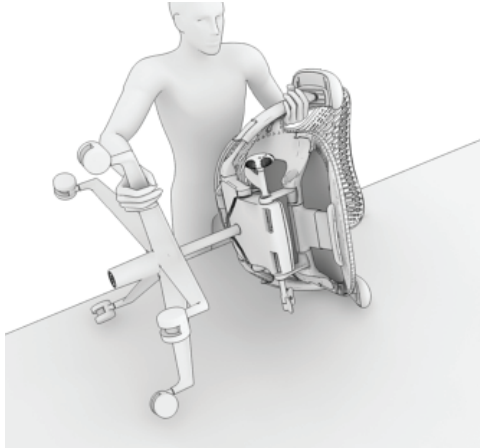

1. Lay the chair on its side.

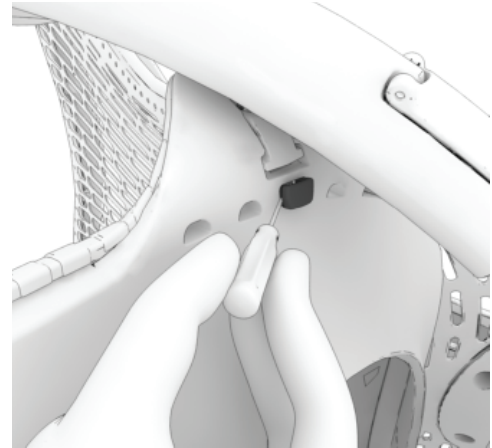

2. Remove the D-Plug from the retainer hole using the small screw driver. Repeat for the opposite side.

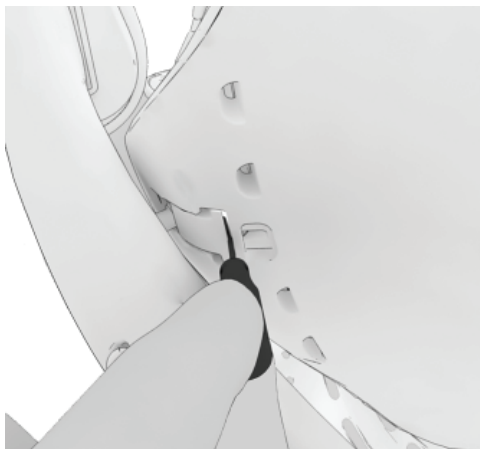

3. Slide the flat head screw driver into slot and depress the spring clip.

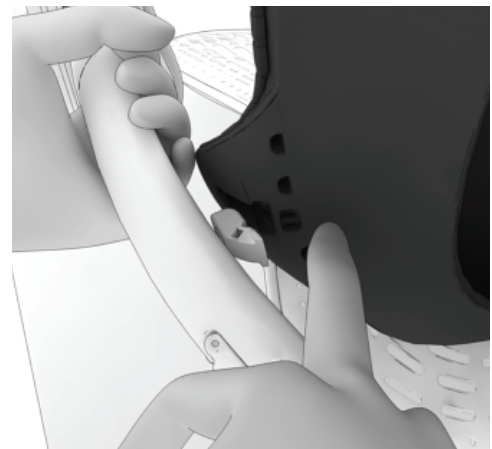

4. Lift up on the seat while depressing the spring clip. Repeat for the opposite side.



5. Stand the chair upright and roll the seat forward.

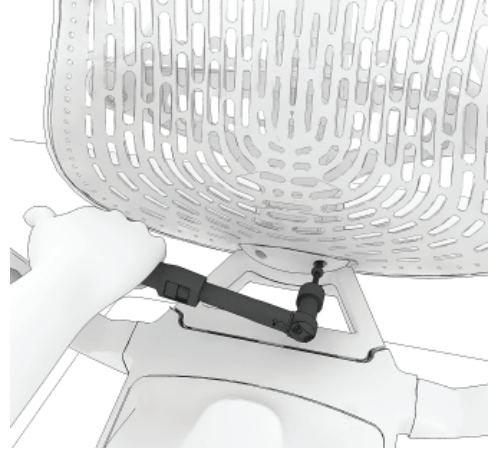

6. Use an extended 4 inch long T27 torx bit to remove the 2 screws at the bottom center of the back.

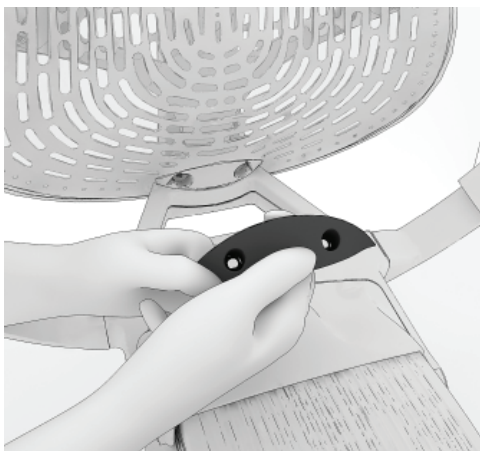

7. Remove the trim cover.

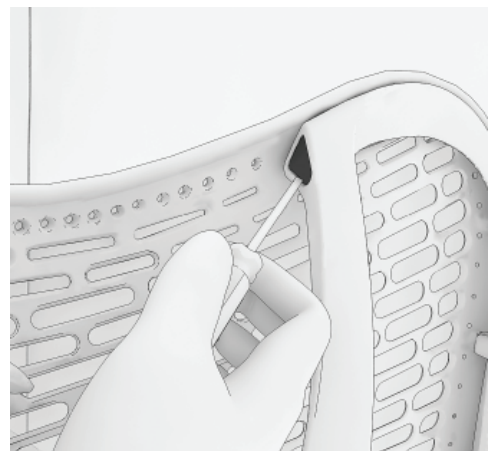

8. Using small flat head screw driver, slide into the gap to remove oval shaped retainer clip.

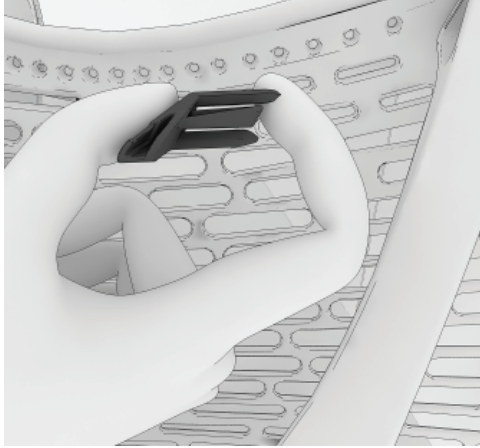

9. Remove the handed clip.
Repeat for the opposite side.

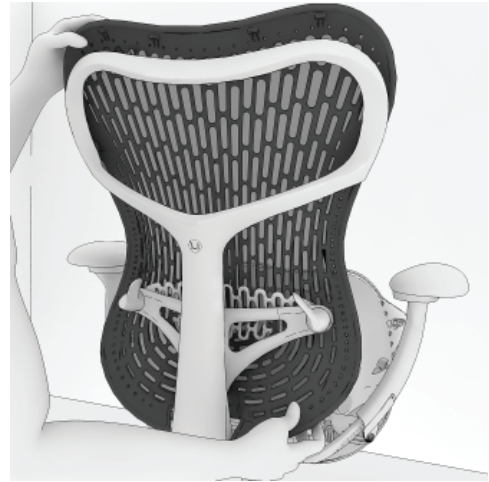

10. Lift up on the bottom and top at the same time to completely take off the back.

Note: Make sure the 4 metal teeth remain intact in the loop.

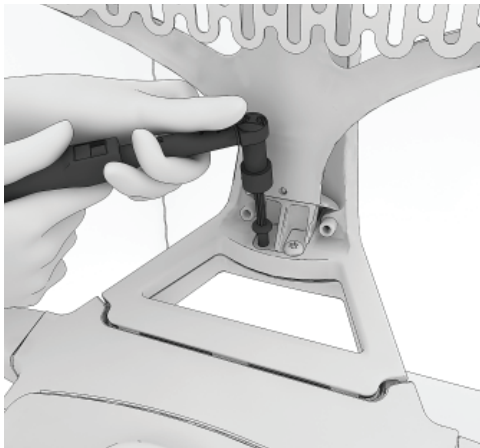

11. Using a T40 torx bit remove the bolts from the back yoke.

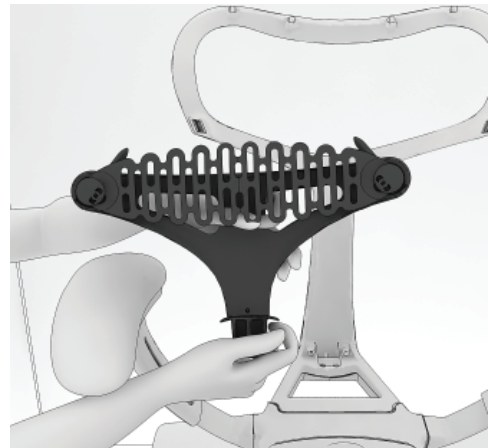

12. Remove the lumbar assembly.

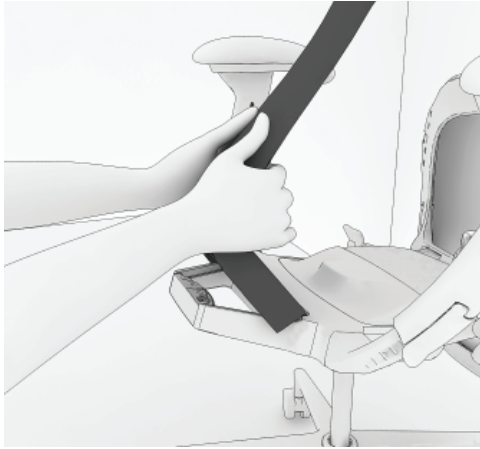

13. Tilt spine forward to remove the spine.

Re-Assembly Steps:

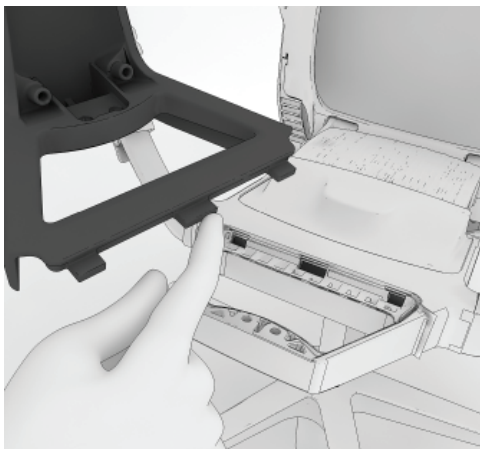

14. Hook the tabs under the slots by leaning the yoke forward.

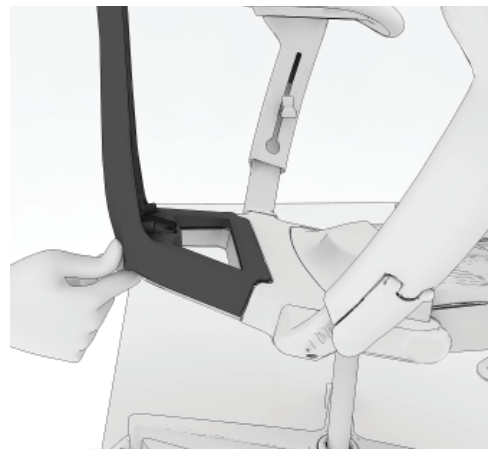

15. Drop it into place and lean back.

HermanMiller

Part no. 1BBSDX rev D.

© 2014 Herman Miller, Inc. Zeeland, Michigan. Printed in the U.S.A.
©  HermanMiller, Mirra 2 are among the registered trademarks of Herman Miller, Inc.

Illustrations and specifications are based on the latest product information available at the time of publication.
The right is reserved to make changes in design and specifications at any time, without notice, and also to discontinue products.

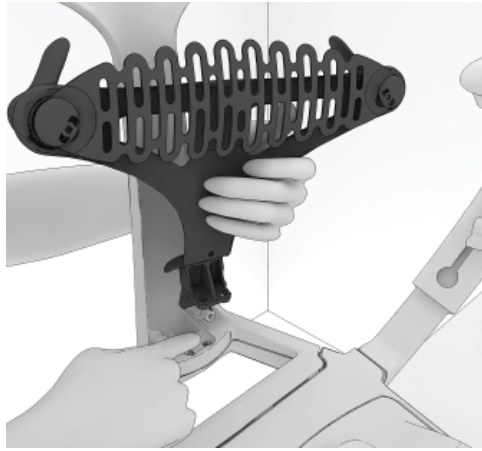

16. Set the Lumbar Assembly into the recess.

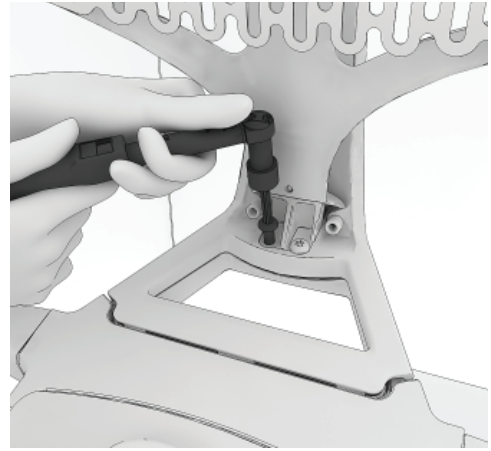

17. Reinstall the bolts. Torque to 220 in/lbs.



18. To reinstall the back pad, ensure that the 4 metal teeth are installed.



19. Hook the top of the pad over the teeth and push it down.

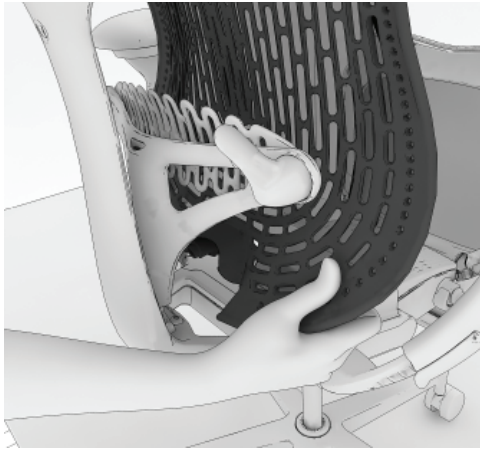

20. Flex the back and slide around the bottom of the spine.

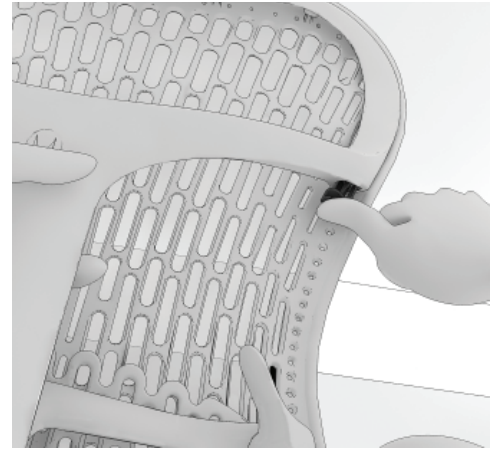

21. Reinsert the retainer clips for the upper back.

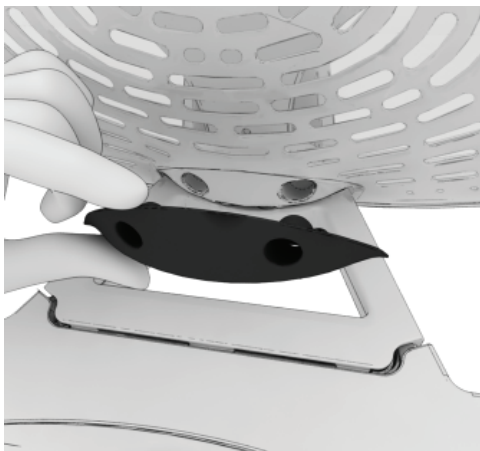

22. Reinstall the trim cover.

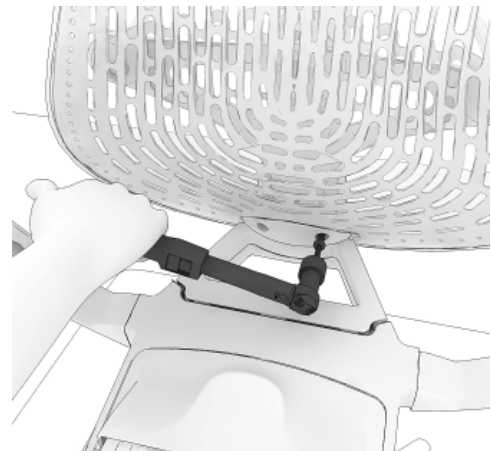

23. Reinstall the bolts using the extended T27 torx bolts. Torque to 70 in/lbs.

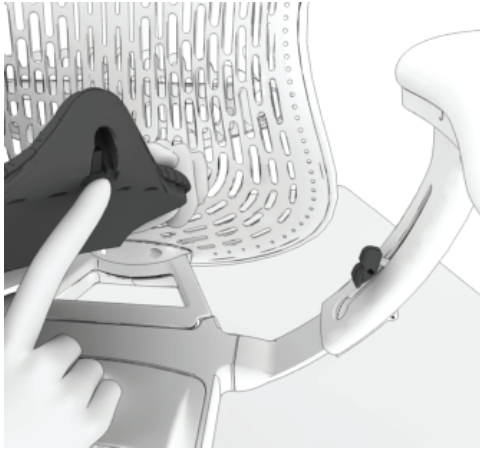

24. Rotate the seat to the In use position sliding the pivot bushing into the keyed opening in the seat.

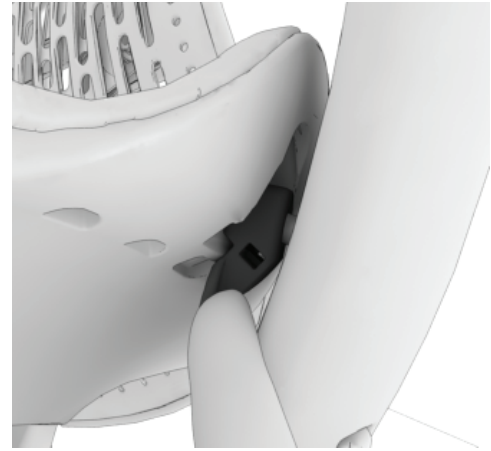

25. Push down until it snaps.

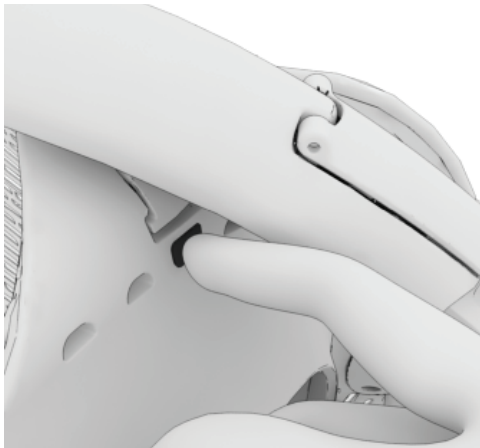

26. Reinstall D-Clips.



27. Check for proper function.



Parts Included:

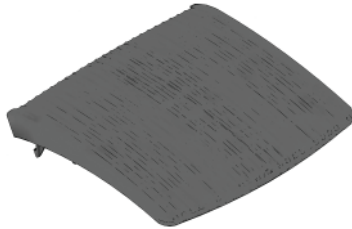

Front Tilt Cover

Tools Required:



Small Flat Head
Screw Driver

Steps:

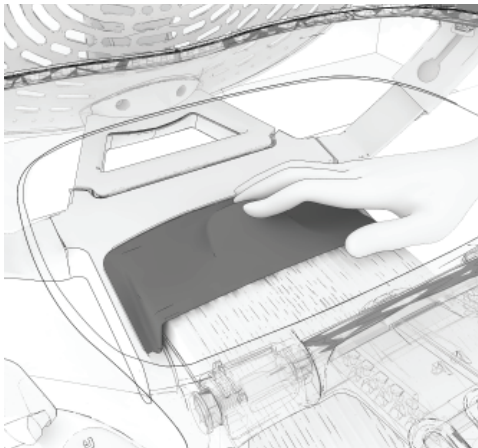

1. Using fingers lift the rear tilt cover.

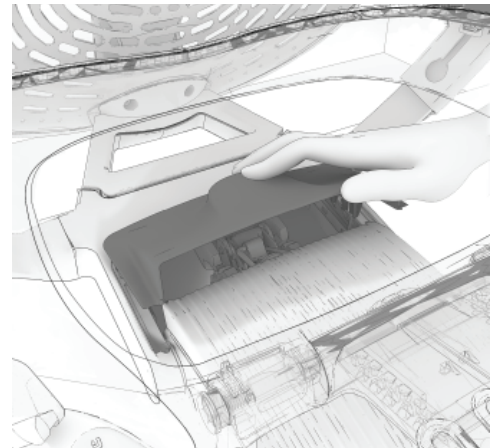

2. Remove cover from the tilt.

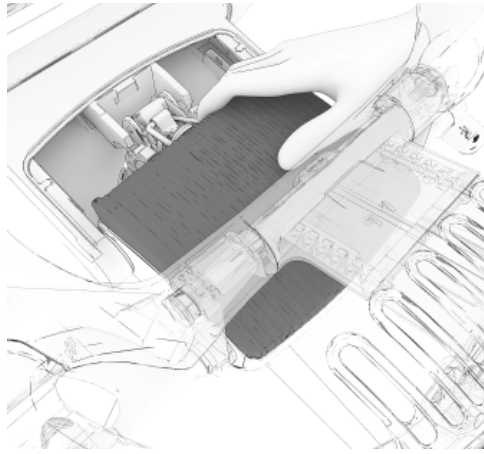

3. Using fingers pull-off the front tilt cover.

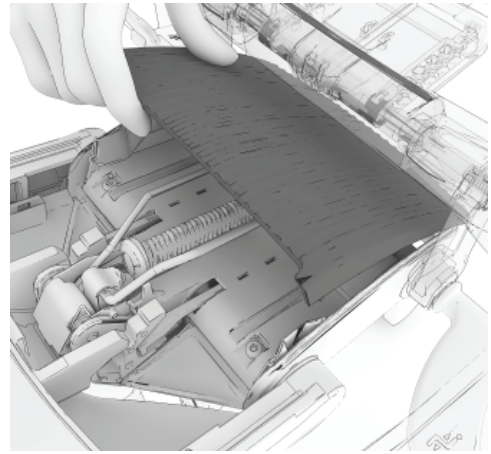

4. Front tilt cover removed from the tilt.

Re-Assembly Steps:

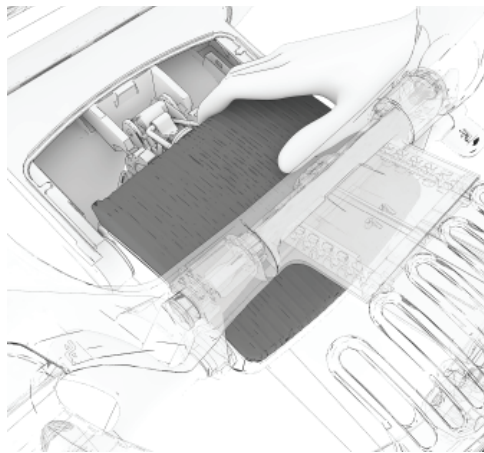

5. Position the new front tilt cover. Snap in place.

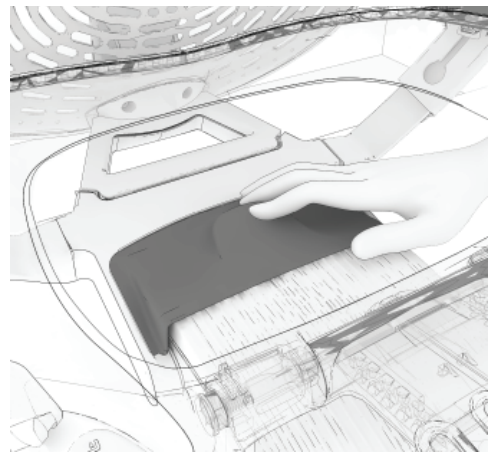

6. Reinstall rear cover.



Parts Included:

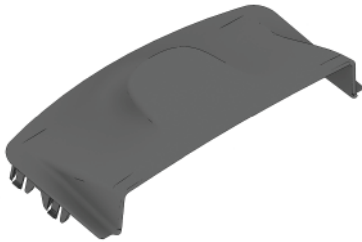

Rear Tilt Cover

Tools Required:



Small Flat Head
Screw Driver

Steps:

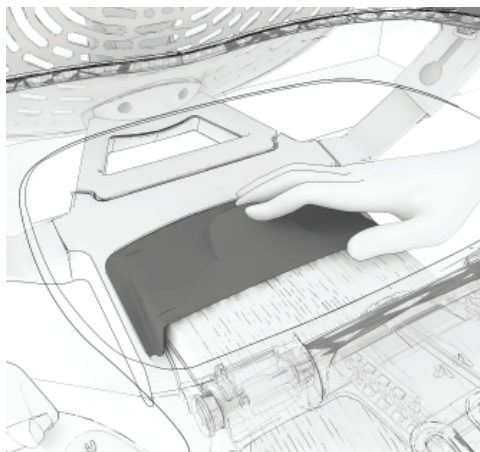

1. Using fingers lift the rear tilt cover and remove.

Re-Assembly Steps:

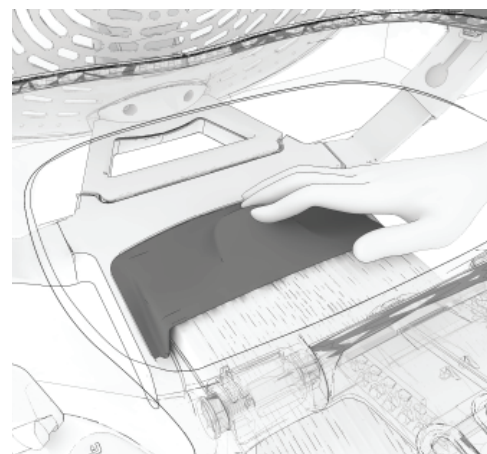

2. Install the new top rear tilt cover and make sure it is snapped in place.



Parts Included:



Bottom Tilt Cover

Tools Required:



Small Flat Head
Screw Driver

Steps:

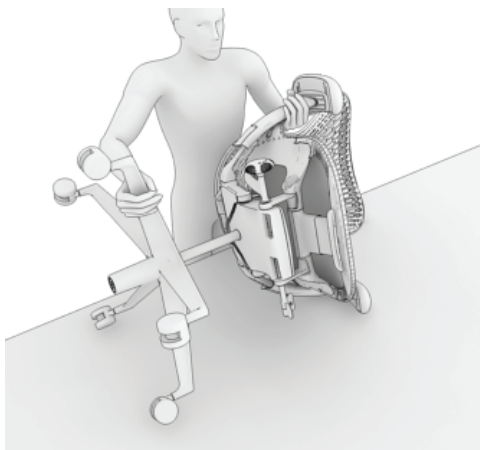

1. Lay the chair on the side.

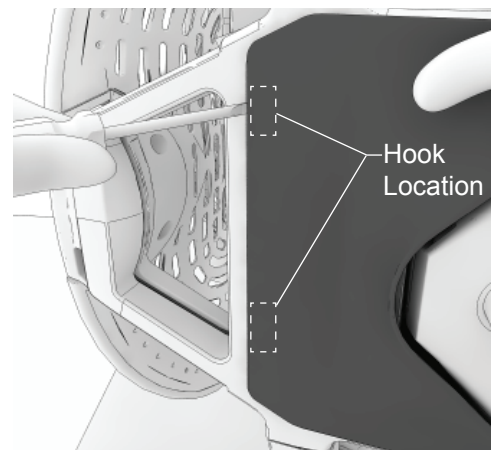

2. Using a small flat head screwdriver depress the two hooks in the back of the bottom tilt cover as shown. Remove the tilt cover.

Re-Assembly Steps:

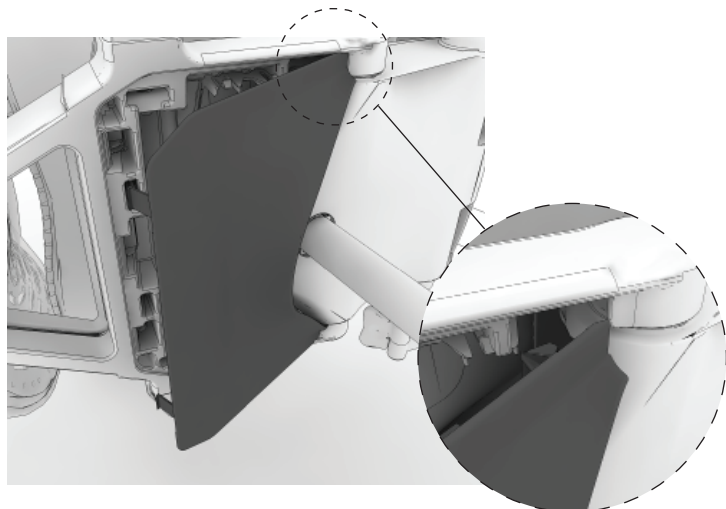

4. Position the open slots on the new bottom cover facing the front of the chair.

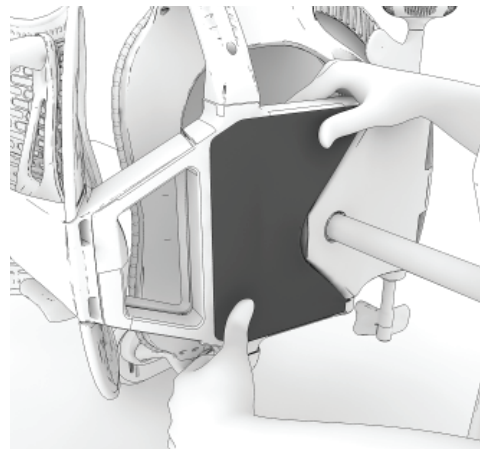

5. Snap cover in place.



Parts Included:

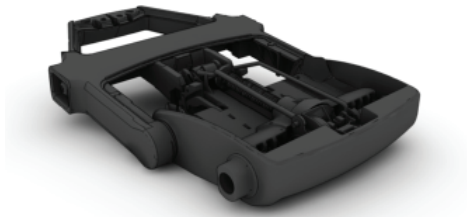

Tilt Assembly

Tools Required:



Small Flat Head
Screw Driver

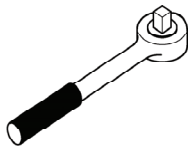

Ratchet Wrench



T40 Torx Bit



4" T30
Torx Bit



2" T27
Torx Bit



Nylon Cap



Lift-off Tool

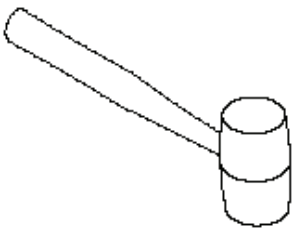

Rubber Mallet

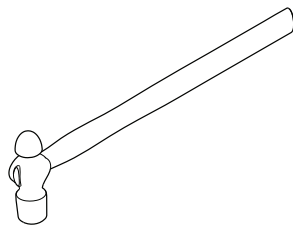

Hammer

Steps:

Seat Removal:

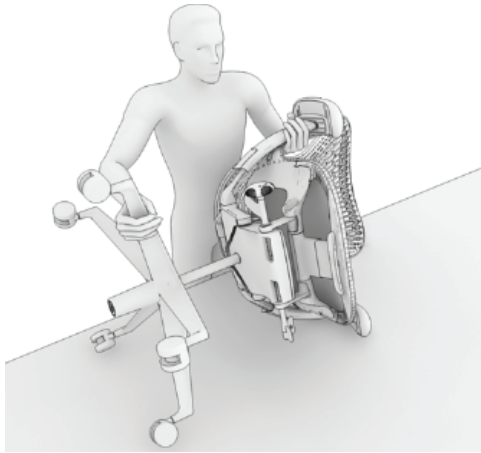

1. Lay chair on its side.

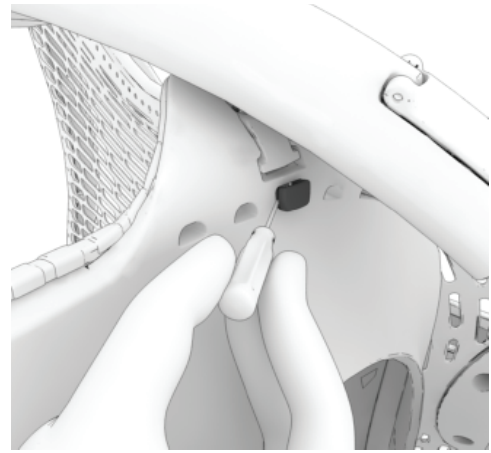

2. Remove the D-Plug from the retainer hole using the small screw driver. Repeat for the opposite side.

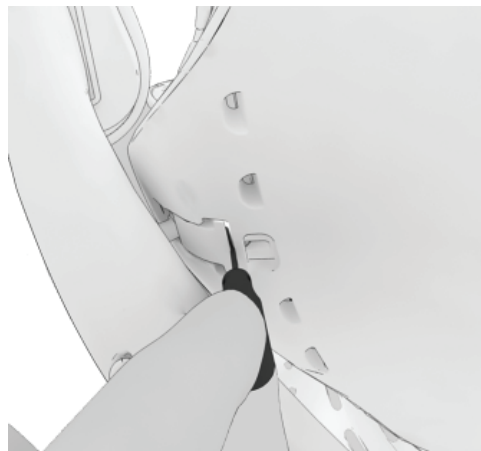

3. Slide the flat head screw driver into the slot and depress the spring clip.

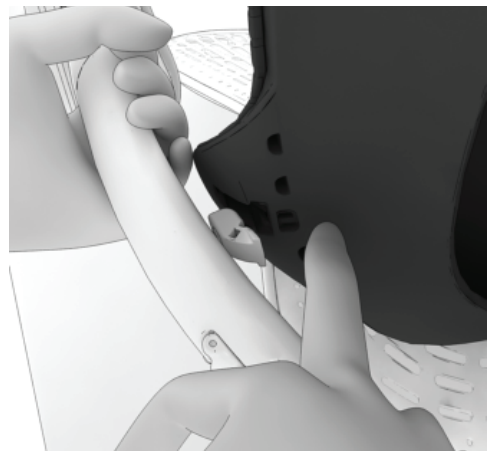

4. Lift upon the seat while depressing the spring clip. Repeat for the opposite side.

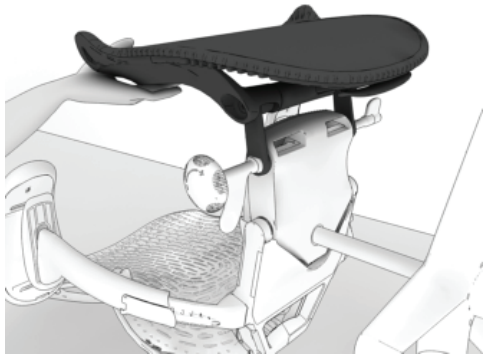

5. Make the seat loosen from the back.

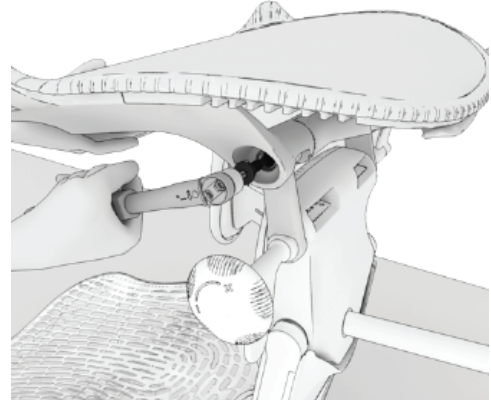

6. Using T40 torx bit remove the retainer bolt. Repeat for the other side.

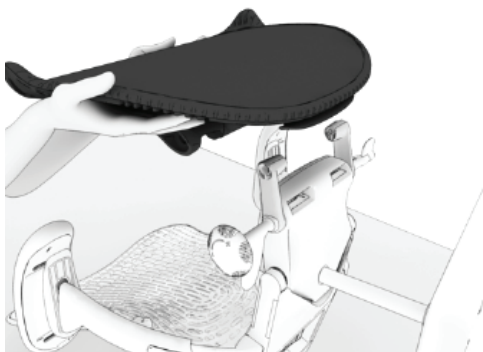

7. Remove the seat from chair.

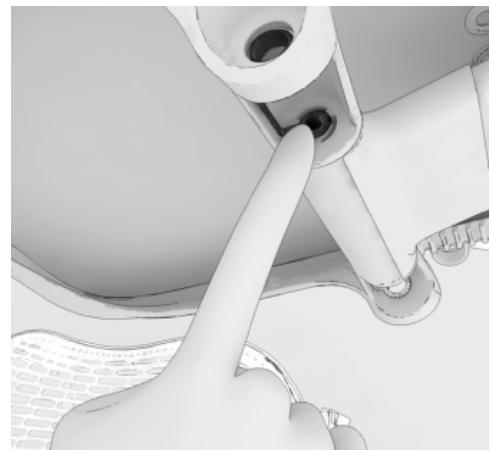

Note: Be careful, not to damage the bushings.

Arm Removal:

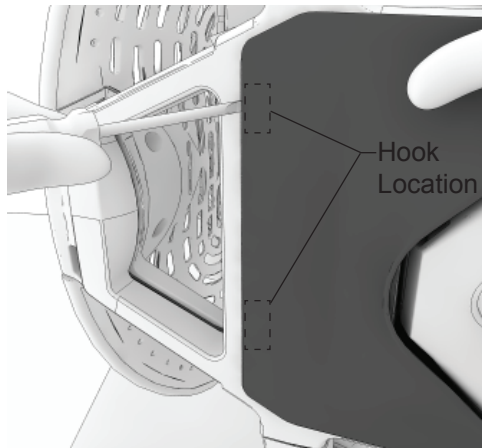

8. Using a small flat head screwdriver depress the two hooks in the back of the bottom tilt cover as shown. Remove the tilt cover.

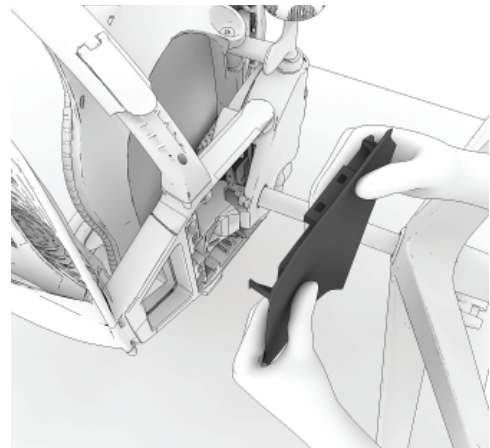

9. Bottom tilt cover removed from the tilt assembly.

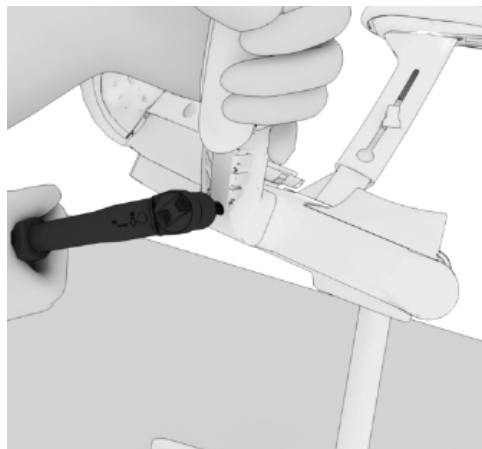

10. Using 6" T40 torx bit remove the arm from tilt assembly



11. While loosening the bolt pull the arm away from the housing and remove the bolt from arm casting.

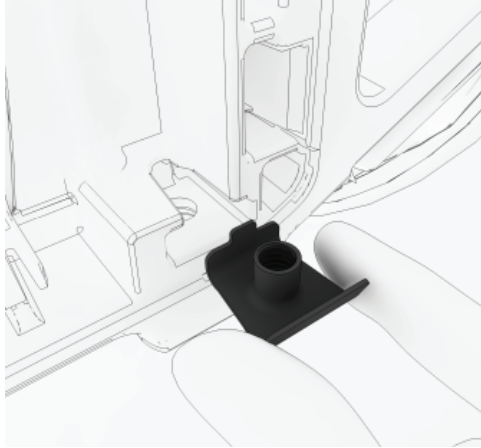

12. Remove the nut plate from the bottom of the tilt assembly.

Back Removal:

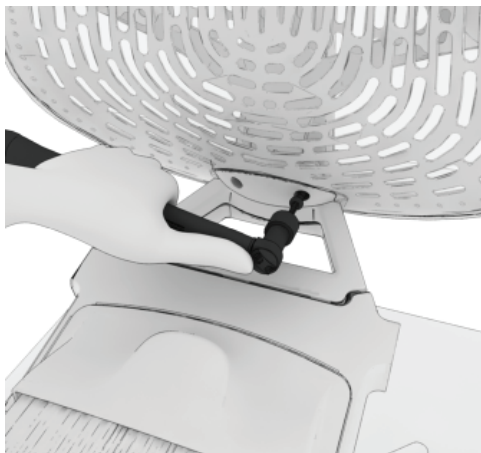

13. Using an extended 4 inch long T27 torx bit to remove the 2 screws at the bottom center of the back.

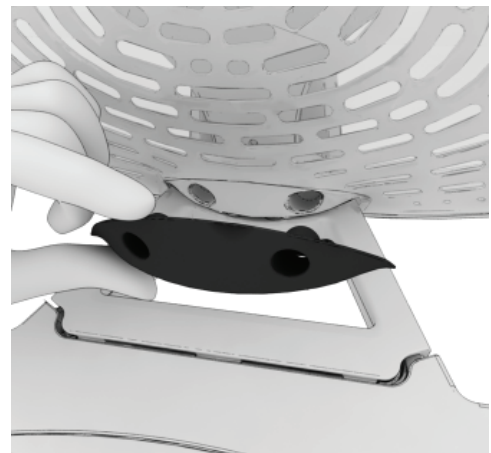

14. Remove the trim cover.

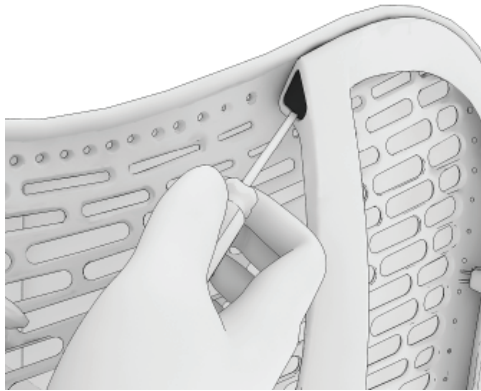

15. Using a small flat head screwdriver, slide into the gap to remove the oval shaped retainer clip.

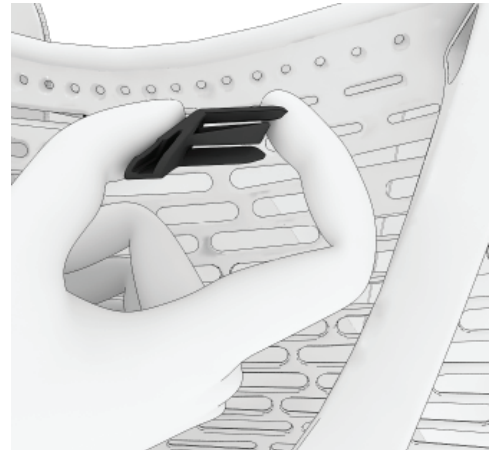

16. Remove the handed clip. Repeat for the opposite side.



17. Lift upon the bottom and top at the same time to completely remove the back.

Note: Make sure the 4 metal teeth remain intact in the loop.

Lumbar Removal:

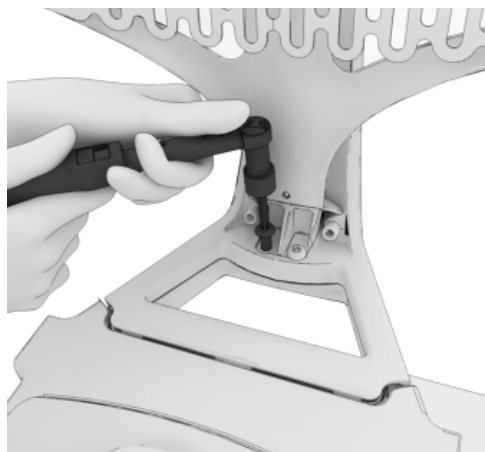

18. Using T40 torx bit remove the bolts from the back yoke.



19. Remove the lumbar stem assembly.

Spine Removal:

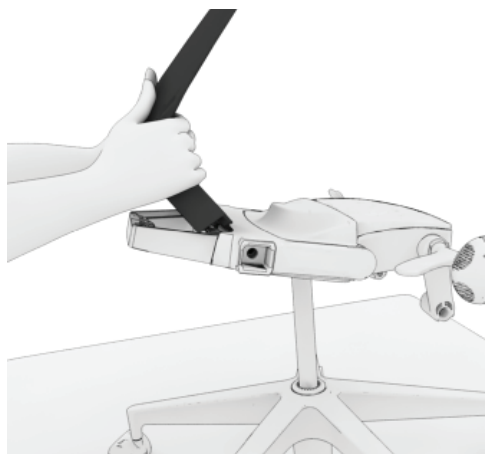

20. Tilt forward to remove the spine.

Tilt Rear Cover Removal:

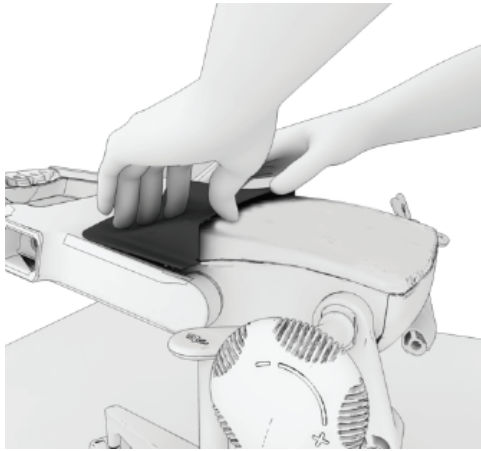

21. Using fingers lift the top rear tilt cover.

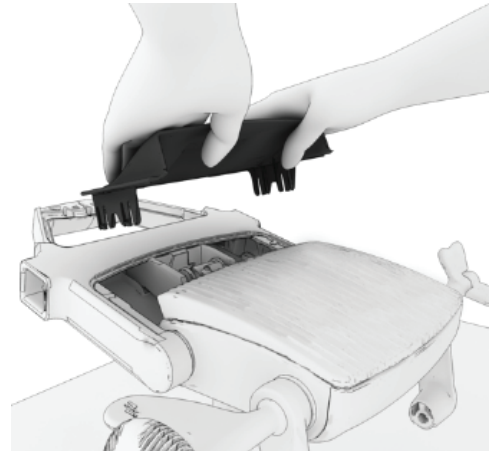

22. Remove the top rear tilt cover from tilt assembly.

Tilt Front Cover Removal:

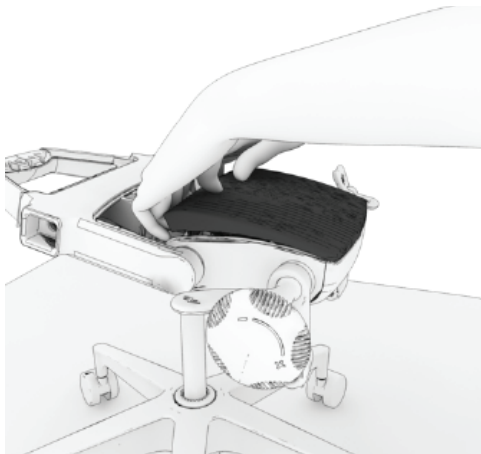

23. Using fingers pull off the top front tilt cover.

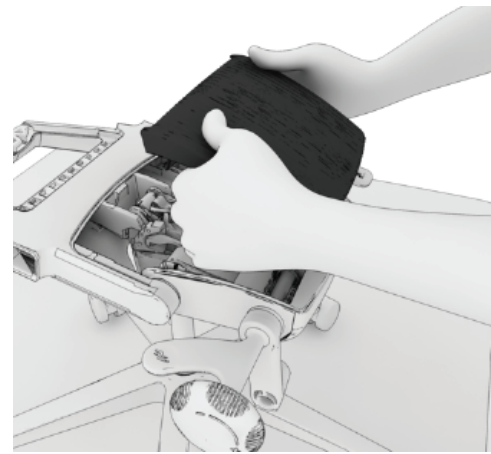

24. Remove the top front tilt cover from tilt assembly.

Bottom Tilt Cover Removal:

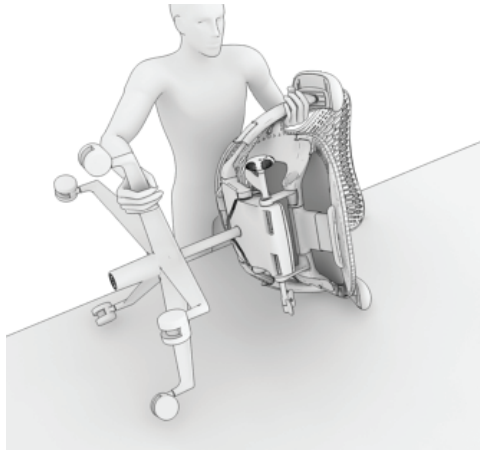

25. Lay the chair on the side.

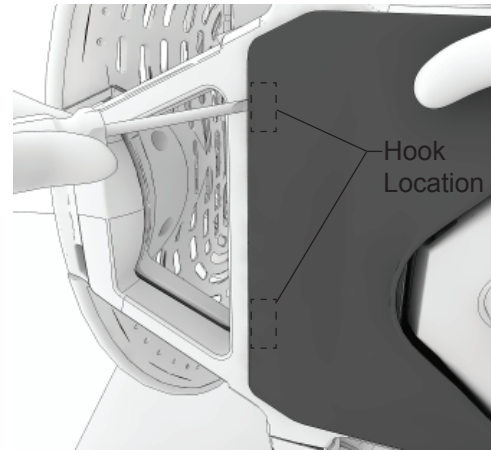

26. Using a small flat head screwdriver depress the two hooks in the back of the bottom tilt cover as shown. Remove the tilt cover.

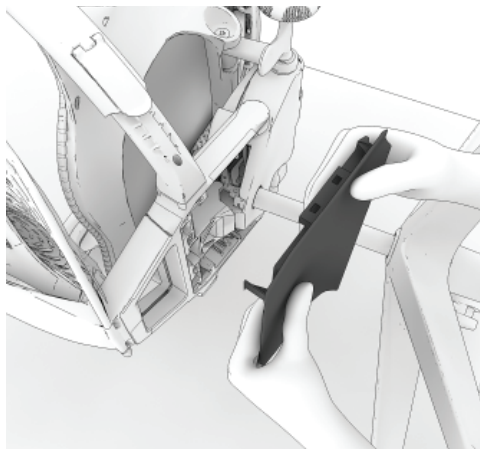

27. Bottom tilt cover removed from the tilt assembly.

Tilt Limit Control Removal:

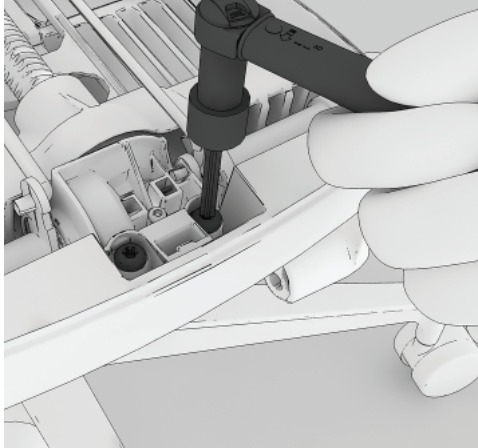

28. Using Phillips screw driver remove the two screws from the control retainer.

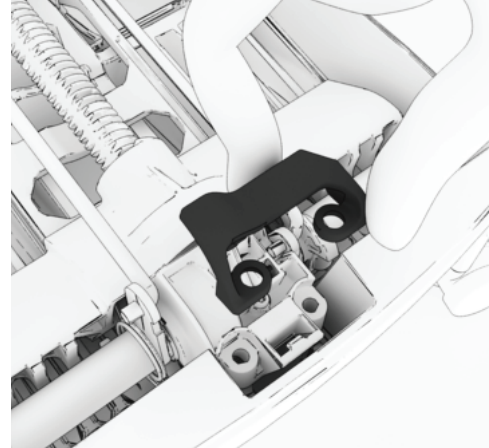

29. The control retainer is removed from the tilt assembly.

Tilt Tension Control Removal:

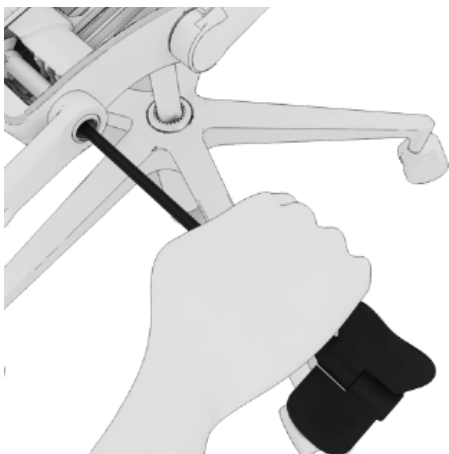

30. Pull the tilt limit control and remove it from the tilt assembly.

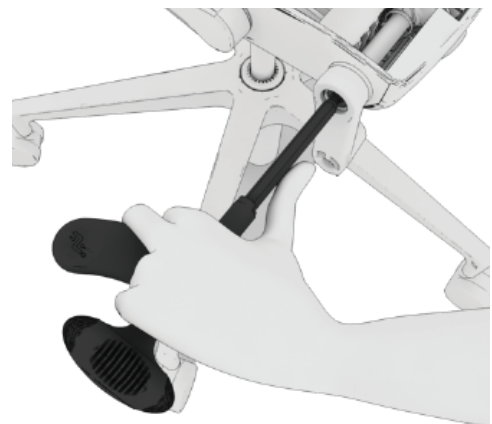

31. Remove the tilt tension control knob and its associated front link from the tilt assembly.

Base Removal:

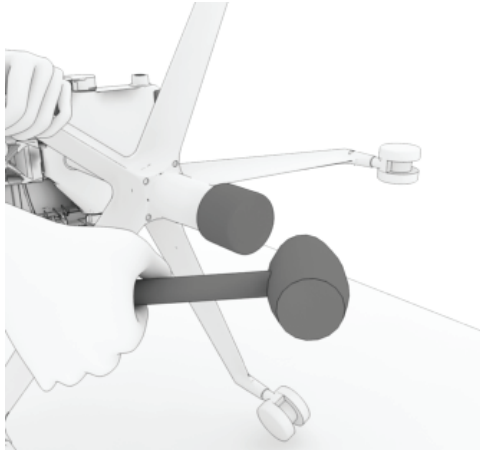

32. Place the nylon cap over the bottom of the cylinder. Using a 2lb hammer strike the cap to dislodge the base from the cylinder.



33. Remove the base from the cylinder.

Cylinder Removal:

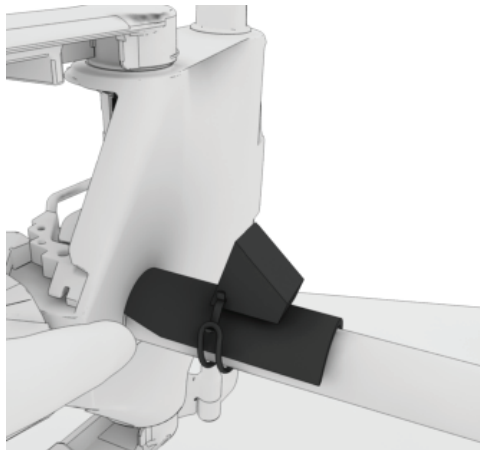

34. Attach the lift-off tool, ensuring that the tapered end of the lift-off tool is against the tilt housing and the striking surface is facing outwards.

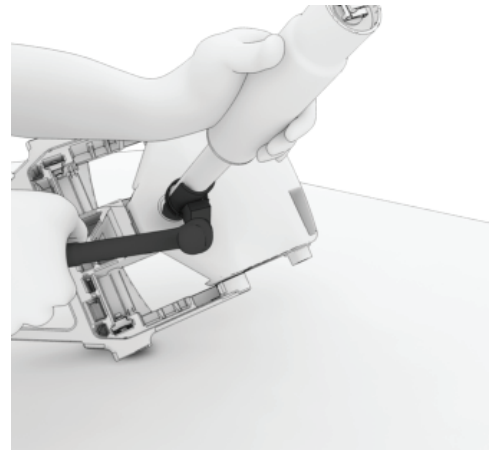

35. While holding the cylinder strike the lift-off tool with a hammer to dislodge the cylinder.



36. Tilt assembly completely removed.

Re-Assembly Steps:



37. Install cylinder onto the base.



38. Place the new tilt assembly onto the top of cylinder.

Tilt Control Installation:



39. Insert new front link into tilt tension control knob.

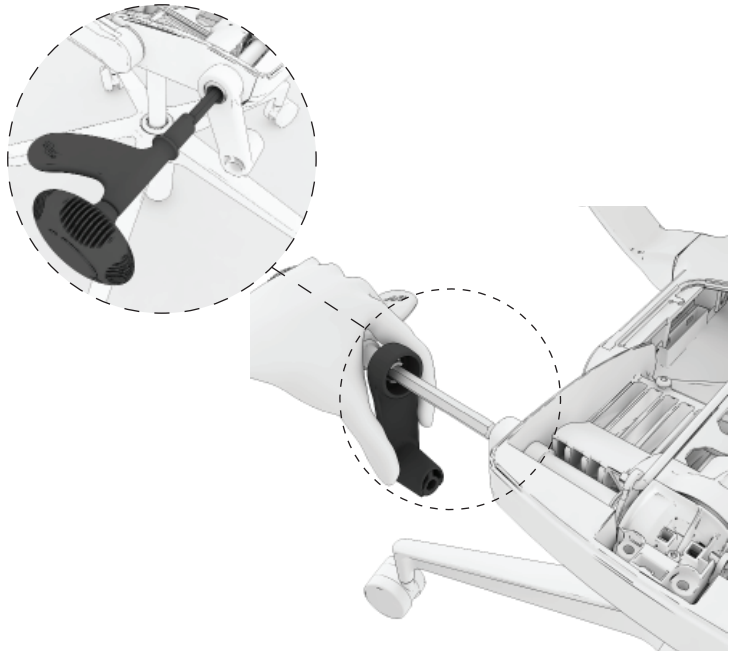

40. Install the tilt tension control knob with front link into tilt assembly.



41. Insert new front link into tilt limit control.

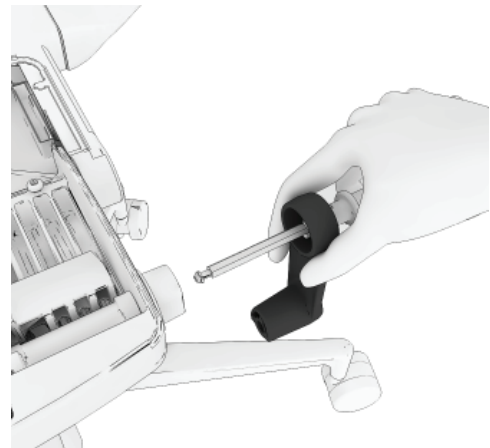

42. Install the tilt limit control with front link into the tilt assembly.

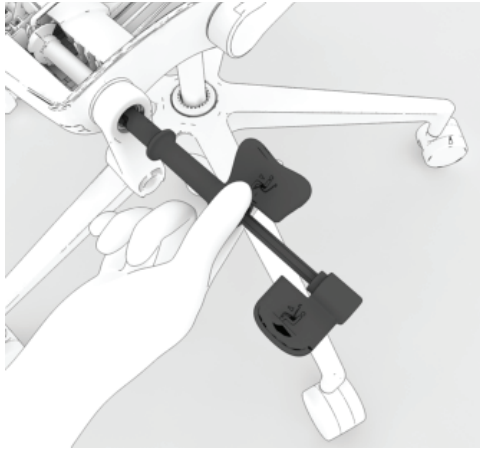

43. Rotate the rear tilt limit control handle until it locks into a key.

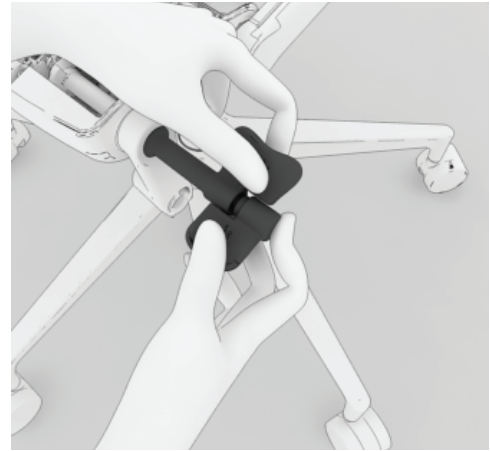

44. Slide the forward angle lever control knob over the rear tilt lever control knob. While applying pressure rotate them together until they snap into the tilt housing.

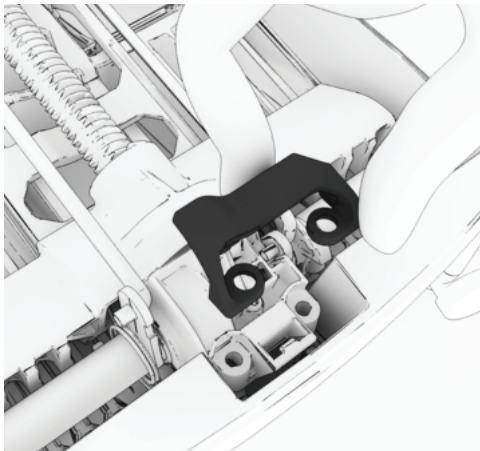

45. Install the control retainer into tilt assembly.

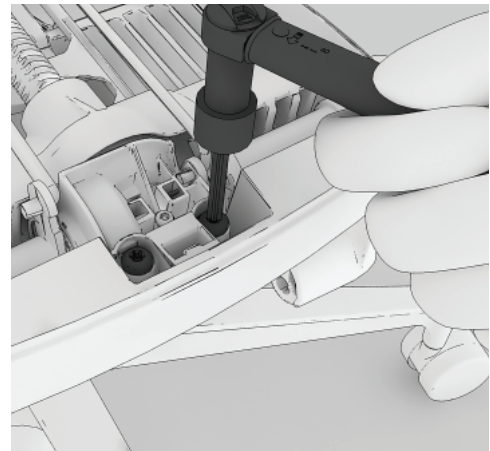

46. Using Phillips screw driver install the two screws. Torque to 60 in/lbs. Check all levers for proper function.

Top Tilt Cover Installation:

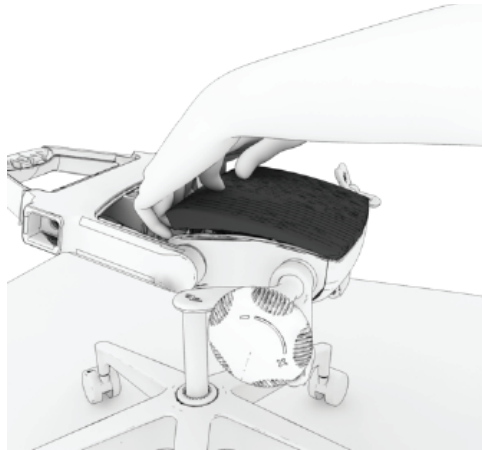

47. Position the top front tilt cover and make sure it is snapped in place.

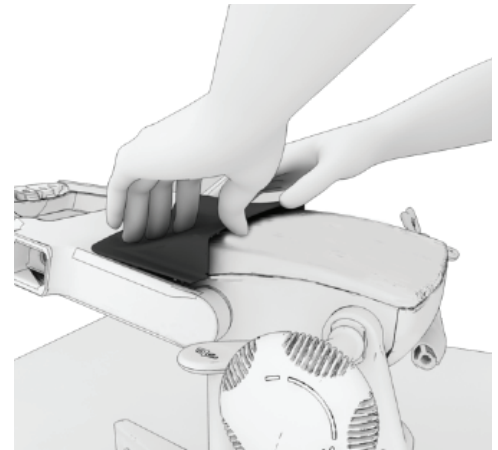

48. Position the existing top rear tilt cover in place and make sure it is snapped in place.

Bottom Tilt Cover Installation:

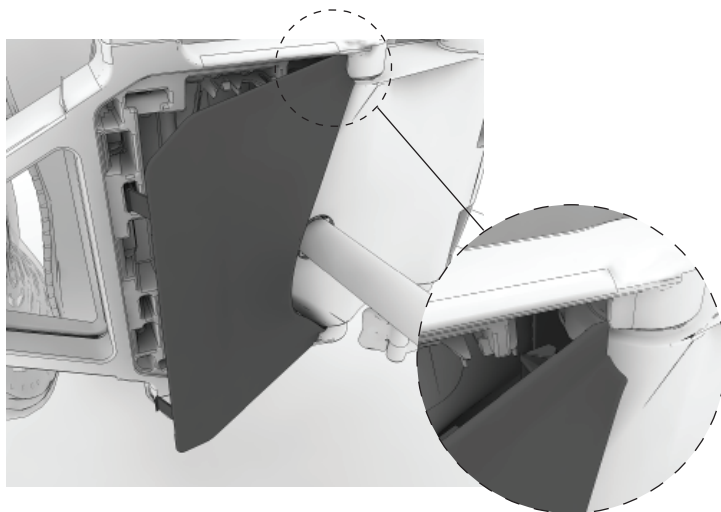

49. Position the open slot on the new bottom tilt cover facing front side of the chair. The slots on the cover should be placed into the bottom tilt assembly.

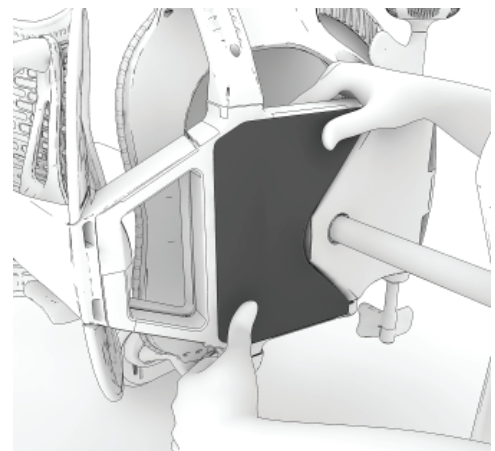

50. Make sure the bottom tilt cover is snapped to the bottom of the tilt assembly.

Spine Installation:



51. Hook the tabs under the slots by leaning the yoke forward.

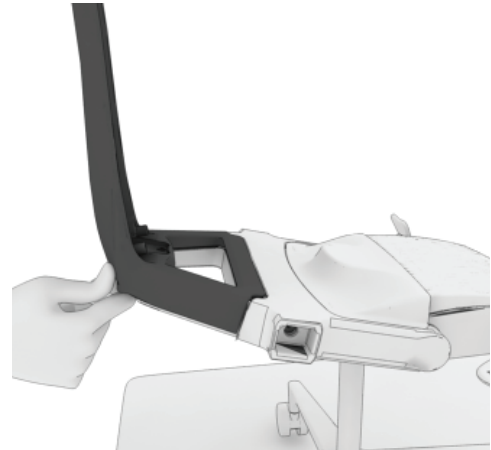

52. Drop into place and lean back.

Lumbar Installation:

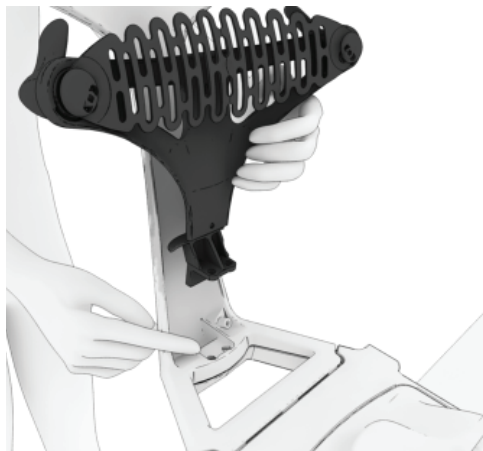

53. Position the lumbar assembly in place.

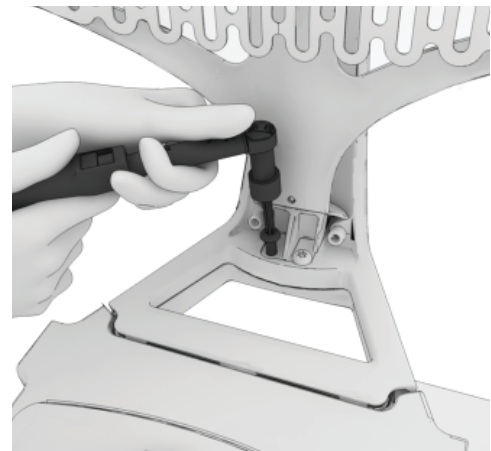

54. Reinstall the bolts.
Torque to 220 in/lbs.

Back Installation:



55. To reinstall the back pad, ensure that the 4 metal teeth are installed.



56. Hook the top of the pad over the teeth and push it down.

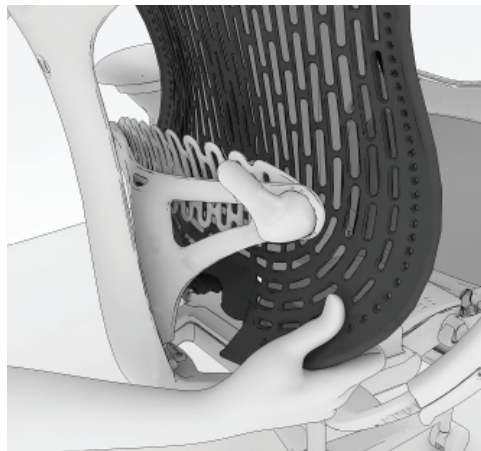

57. Flex the Back and slide around the bottom of the spine.

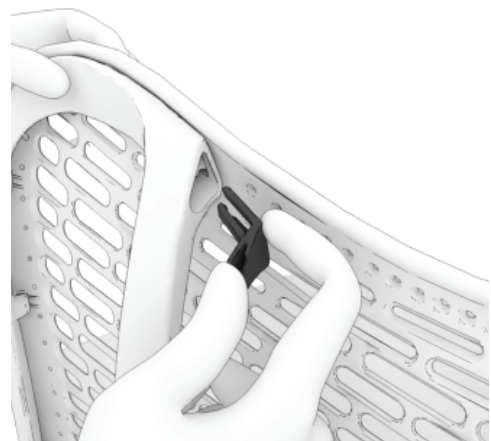

58. Re-insert the retainer clips for the upper back.

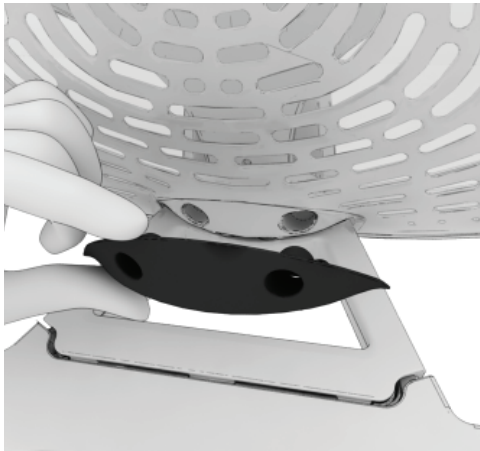

58. Reinstall the trim cover.

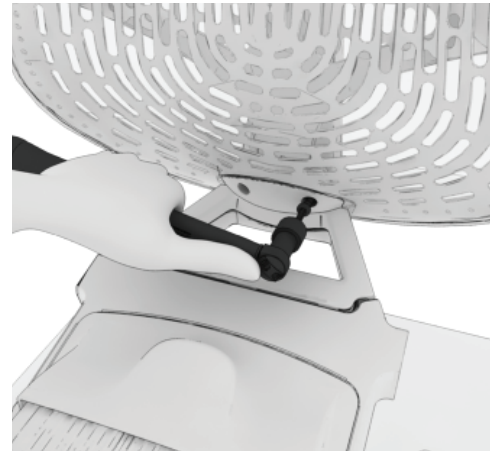

59. Re-install the bolts using the extended T27 torx bits. Torque to ?? in/lbs.

Arm Installation:

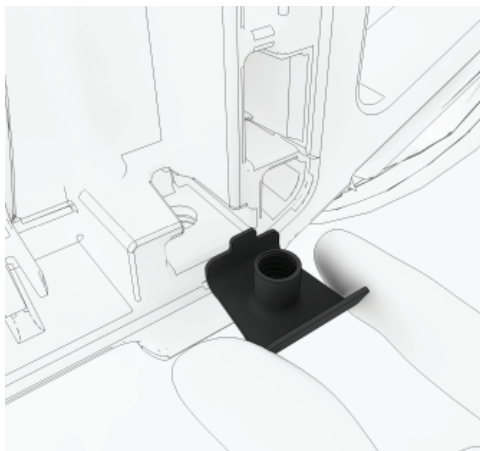

60. Place the nut plate on the bottom of the tilt assembly.

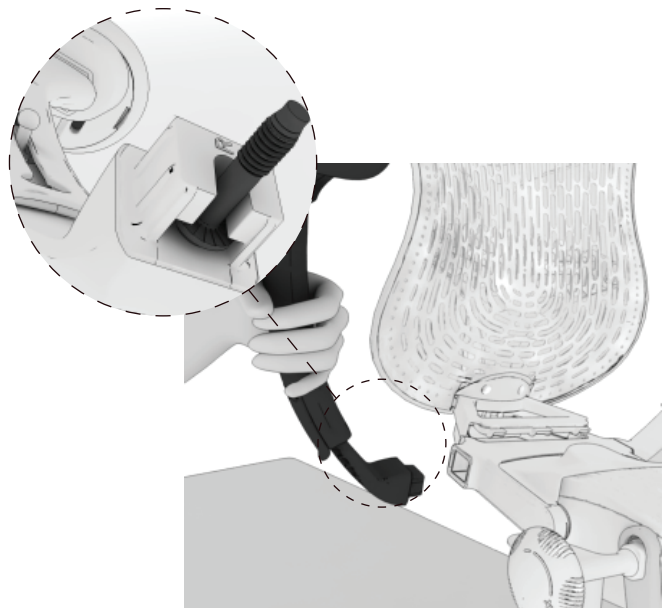

61. Place the bolt into arm casting slot.

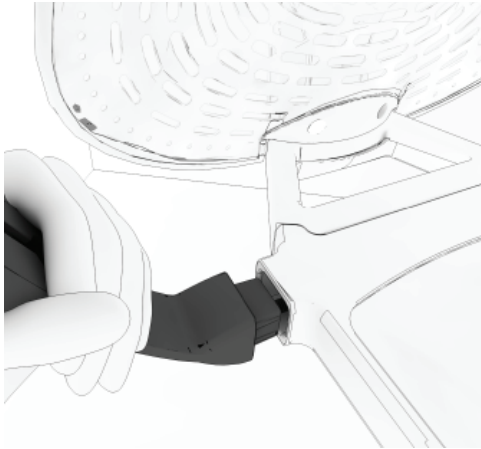

62. Position the arm in place.

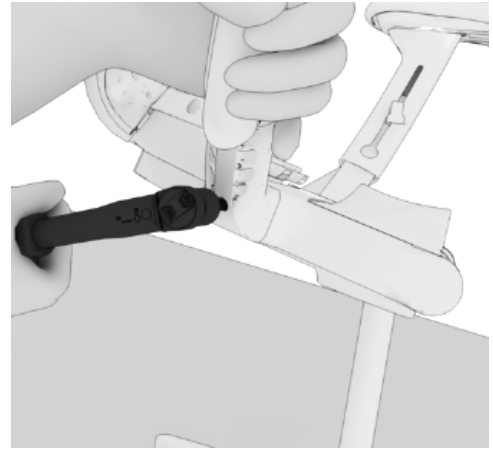

63. Using 6" T40 torx bit tighten the bolt. Torque to 330 in/lbs. Repeat on opposite side.

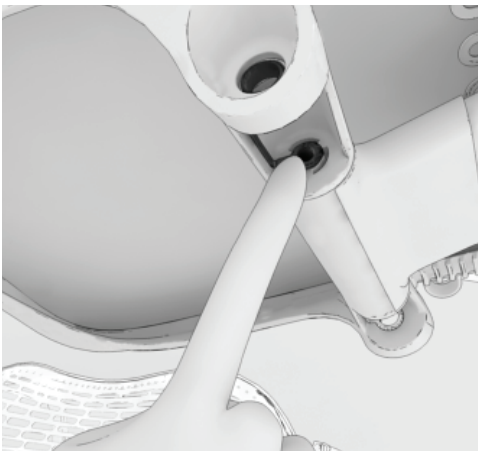

Note: Before re-attaching the seat to the front links make sure the bushings are still in place.

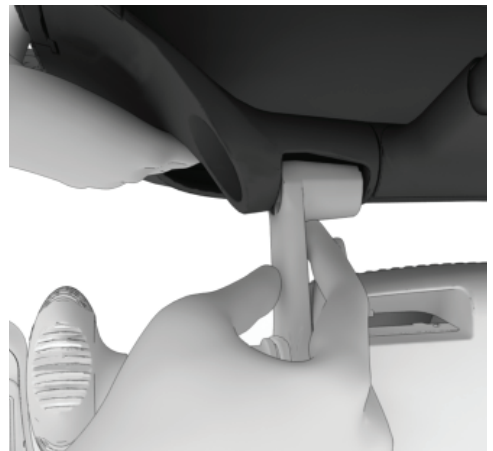

64. Rotate the seat down over the front links.

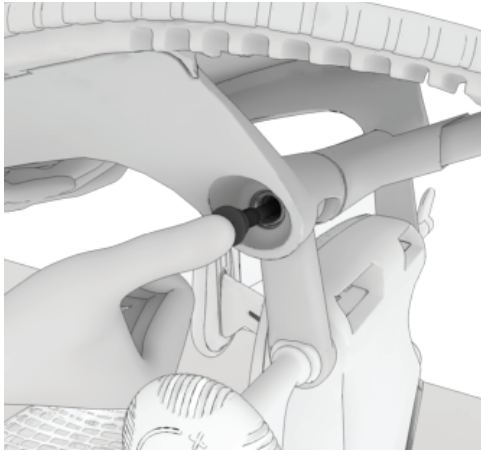

65. Install bolts on both sides.

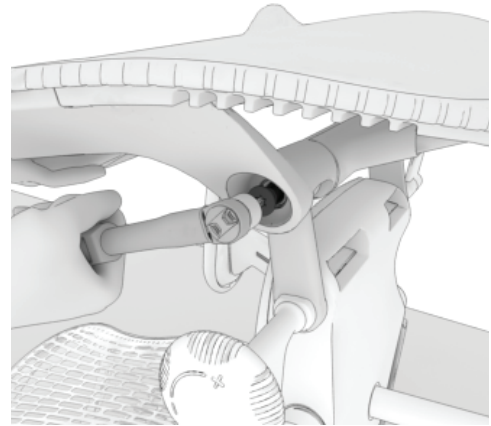

66. Using T40 torx bit, tighten the bolts to the torque 300 in/lbs.

Caution: Do not over torque, you may strip the thread.

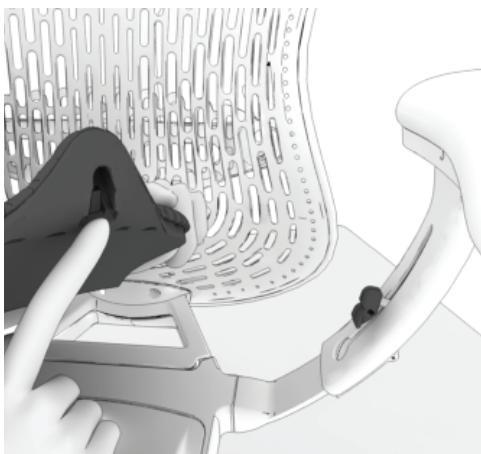

67. Rotate the seat to the end use position sliding the Pivot Bushing into the keyed opening in the seat.

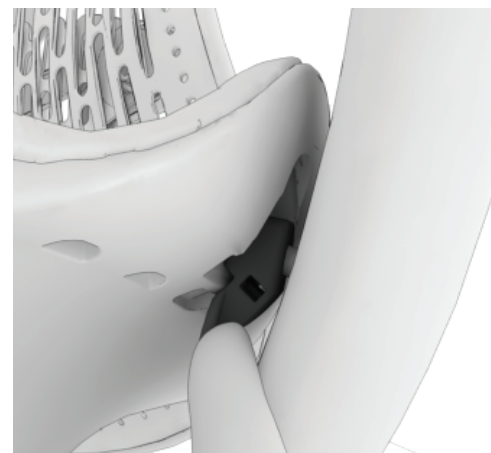

68. Push down until it snaps.

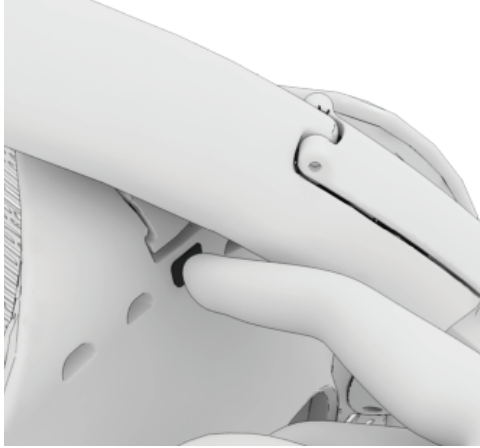

67. Install D-clips.

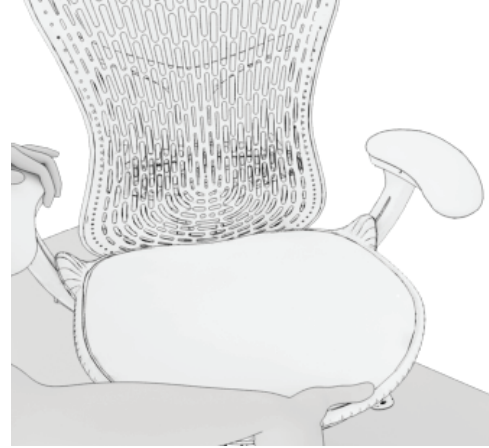

67. Check for proper function.



68. Sit on chair firmly several times to set cylinder and base.



Parts Included:



Arm Assembly

Additional notes:

New Style Arm Support Post Implemented 9/2016



Old Style



New Style

Tools Required:



Small Flat Head
Screw Driver

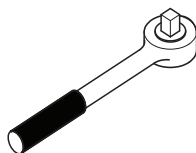

Ratchet Wrench



13mm deep Socket

Steps:

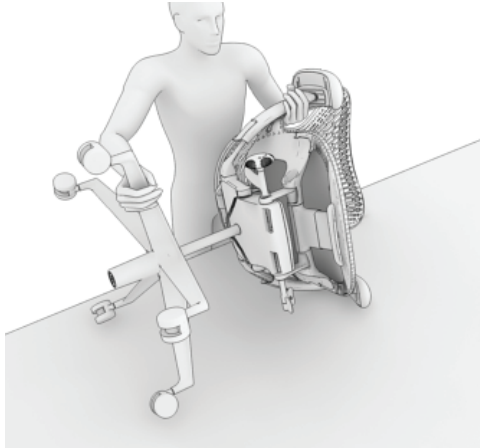

1. Lay the chair on its side.

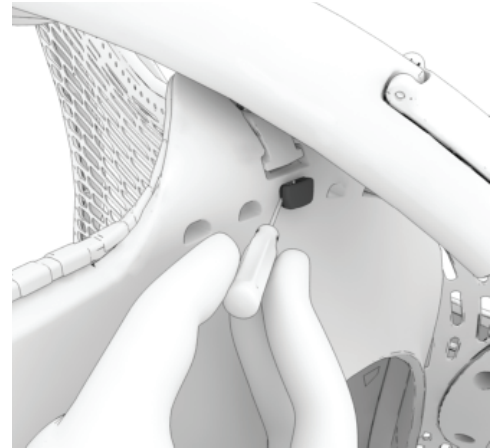

2. Remove the D-Plug from the retainer hole using the small screw driver. Repeat for the opposite side.

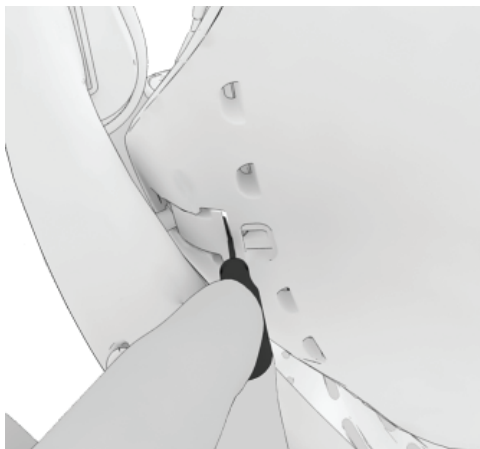

3. Slide the flat head screw driver into slot and depress the spring clip.

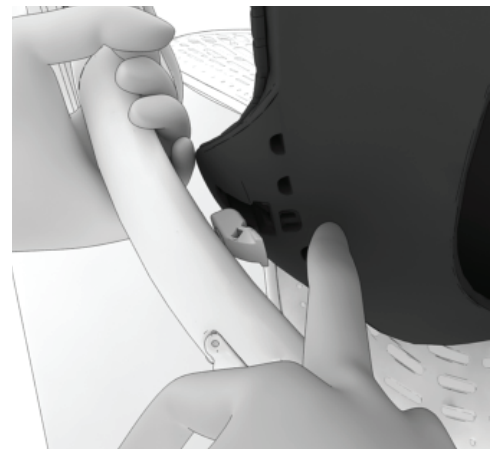

4. Lift up on the seat while depressing the spring clip. Repeat for the opposite side.



5. Stand the chair upright and roll the seat forward.

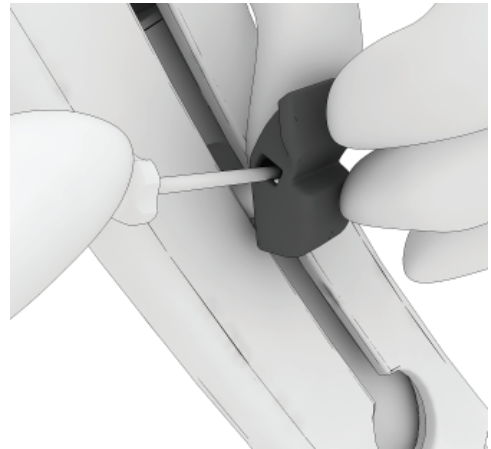

6. Rotate the Hip Pivot Bushing upside down. Insert the flathead screw driver into the hole and release the tab by depressing the clip.

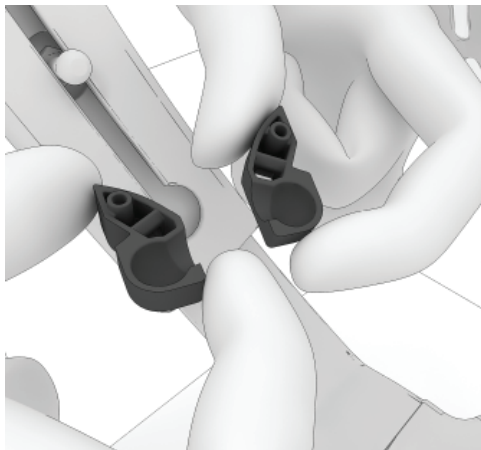

7. Hip Pivot Bushing removed.



8. Align the key hole in the arm with the arm support post.

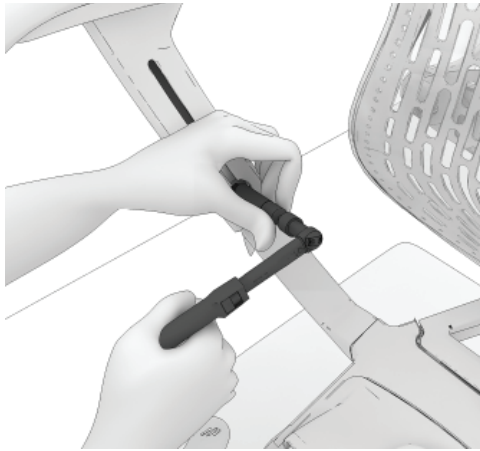

9. Using 13mm deep socket remove the Arm Support Post.

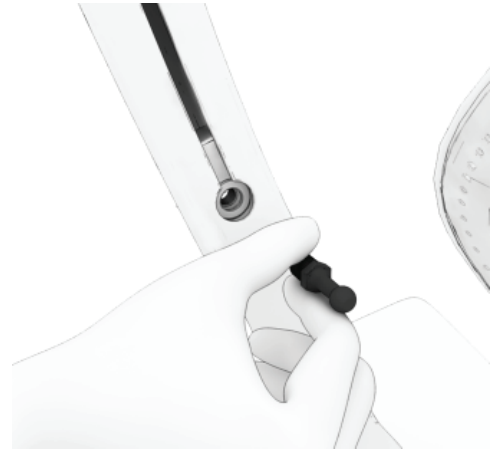

10. Arm Support Post removed.



11. Remove the washer from arm. New Arm Support Post does not use washer.

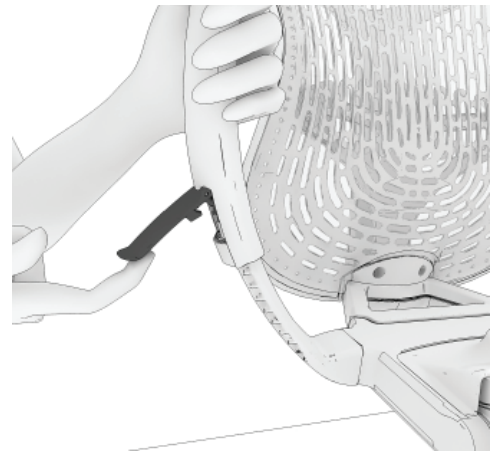

12. Release the catch on the arm.

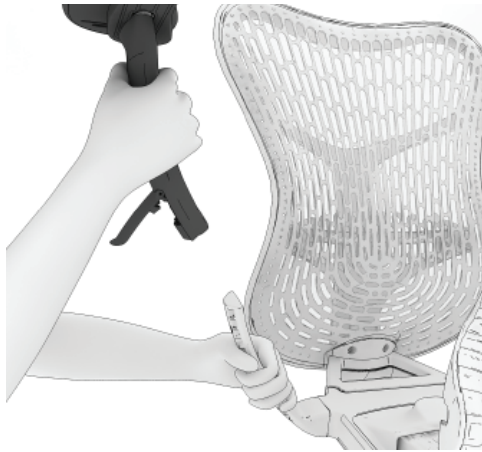

13. Slide the entire assembly up to remove the arm.

Re-Assembly Steps:

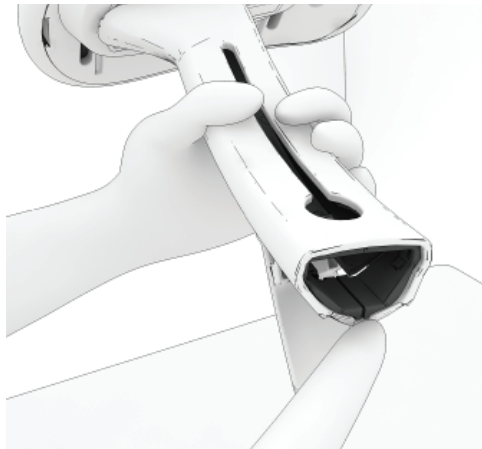

14. While installing new arm assembly make sure the plastic bearing is seated inside the arm. It may be extended out.

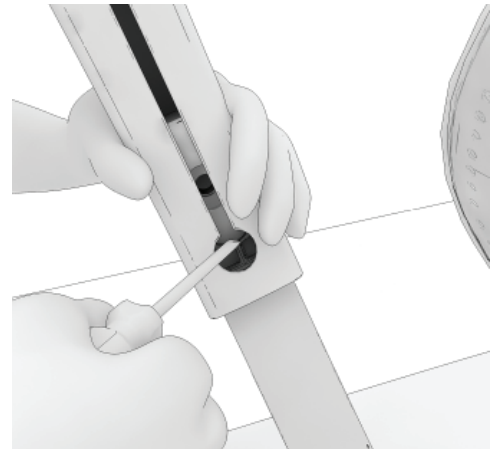

15. Using flat head screw drive slide the sleeve back down if it is not in properly seated.

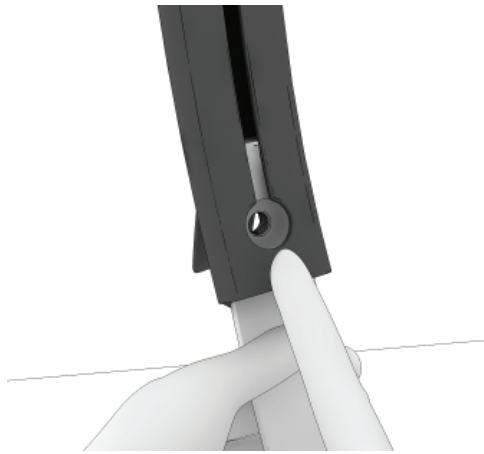

16. Align the keyed opening in the arm up with the hole in the arm support casting.



17. Install the washer into arm. New Arm Support Post does not use washer.



18. Hand start the Arm Support Post.

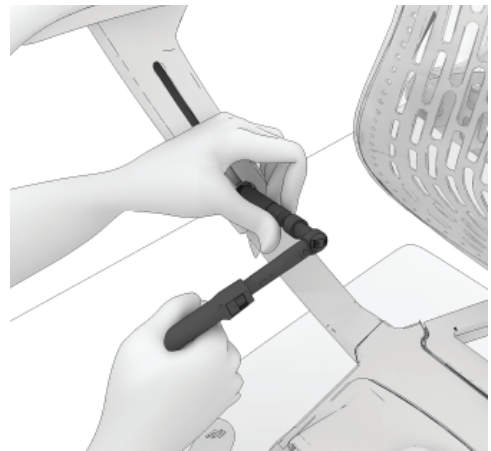

19. Using a 13mm deep socket tighten the Arm Support Post. Torque to 300 in/lbs.

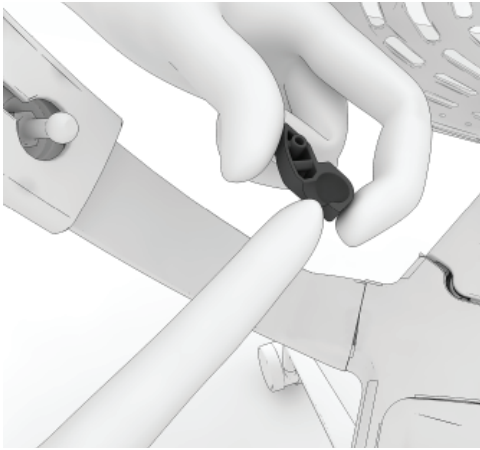

20. Install the Hip Pivot Bushing on the ball end of the Arm Support Post. Note: The bushing will only go on one way.

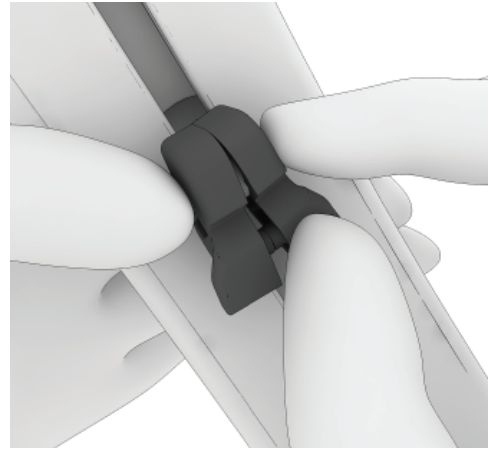

21. Snap the two halves of the Hip Pivot Bushing together.

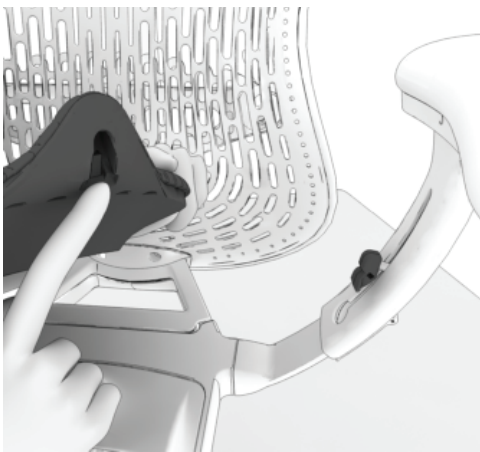

22. Rotate the seat to the end use position sliding the Pivot Bushing into the keyed opening in the seat.

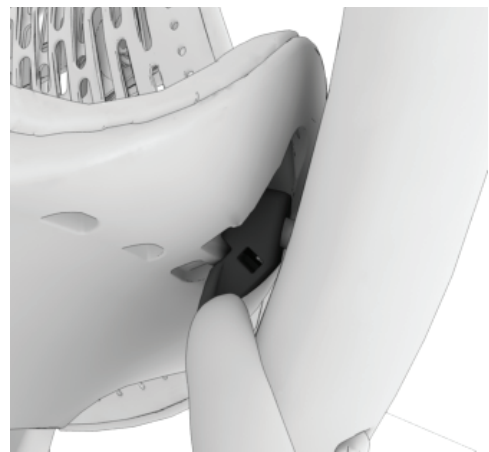

23. Push down until it snaps.



24. Reinstall D-Clips.

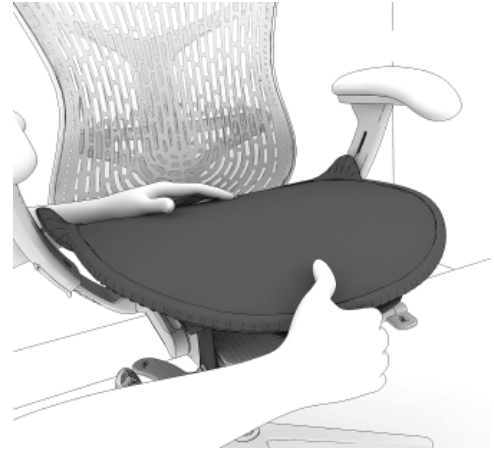

25. Check for proper function.



Parts Included:



Arm Pad

Tools Required:



T-20 Torx Driver

Steps:

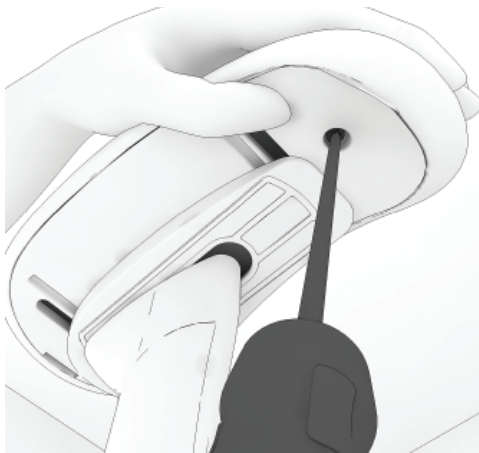

1. Using philips T20 torx bit remove the front arm pad bolt.



2. Lift up the arm pad and slide it off.

Re-Assembly Steps:

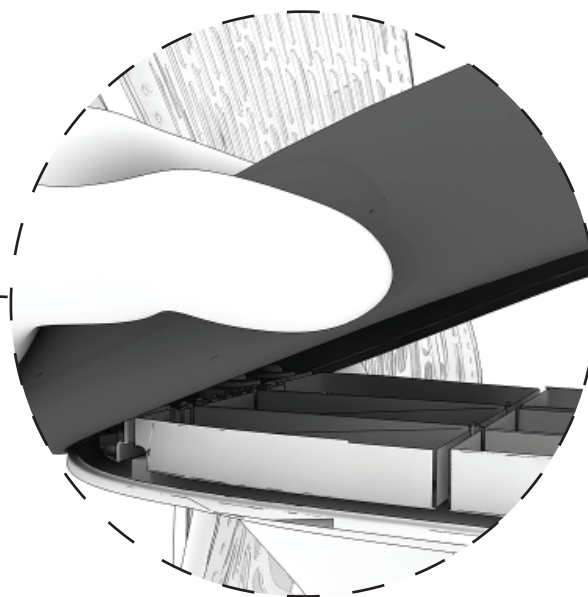
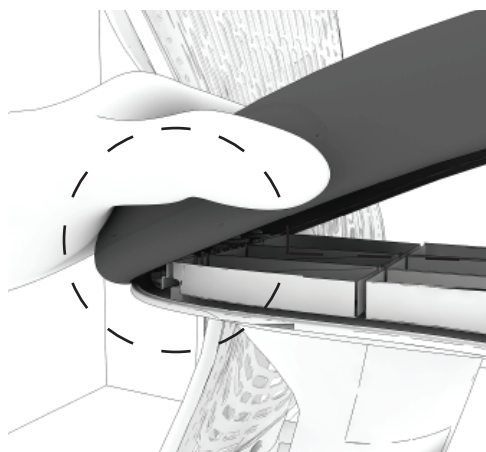

3. Hook the slot on the arm pad to the tab on the arm plate and rotate the arm pad down.

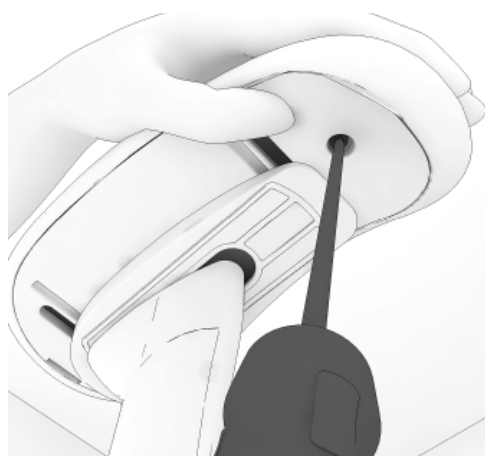

4. Reinstall the bolt. Torque to 15 in/lbs.



Parts Included:



4D Arm Pad Plate



Fixed/1D Arm Pad Plate

Tools Required:



T-20 Torx Driver

Steps:

4D Arm Pad Support Plate Removal

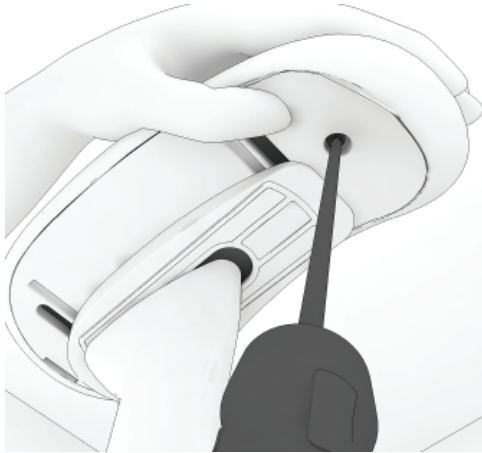

1. Using philips T20 torx bit remove the front arm pad bolt.



2. Lift up the arm pad and slide it off.

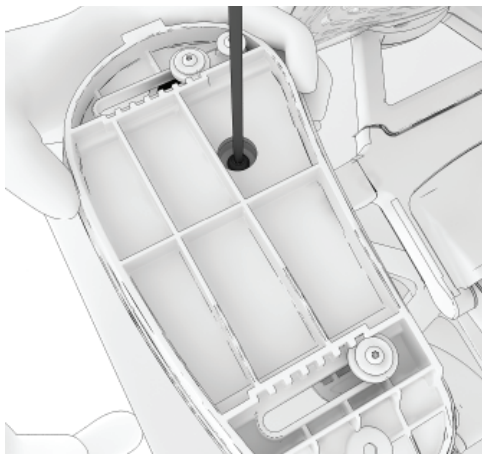

3. Using a T20 torx bit remove the single screw in the center of the arm pad support plate.

Note: slide the arm pad support plate to gain access to the screw.

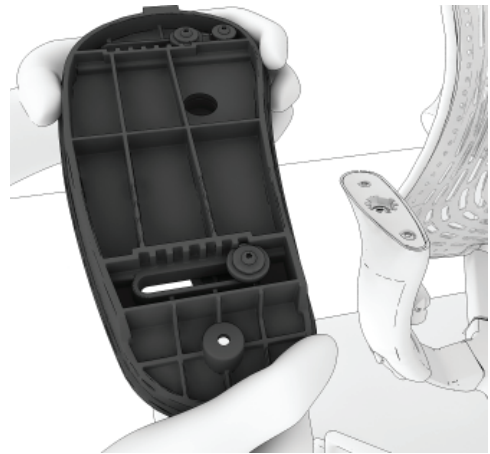

4. Arm pad support plate removed.

HermanMiller

Part no. 1BBSF4 rev D.

© 2014 Herman Miller, Inc. Zeeland, Michigan. Printed in the U.S.A.
©  Herman Miller, Mirra 2 are among the registered trademarks of Herman Miller, Inc.

Illustrations and specifications are based on the latest product information available at the time of publication. The right is reserved to make changes in design and specifications at any time, without notice, and also to discontinue products.

1D & Fixed Arm Pad Support Plate Removal

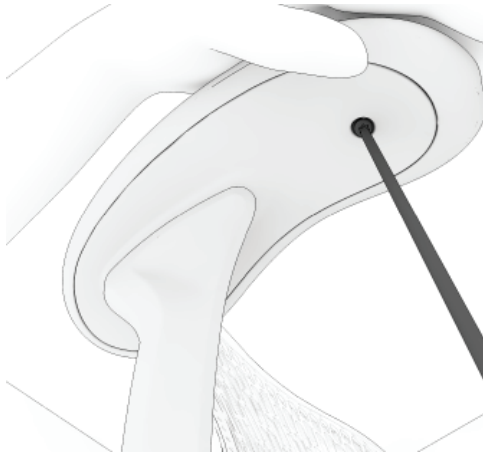

5. Using philips T20 torx bit remove the front arm pad bolt.

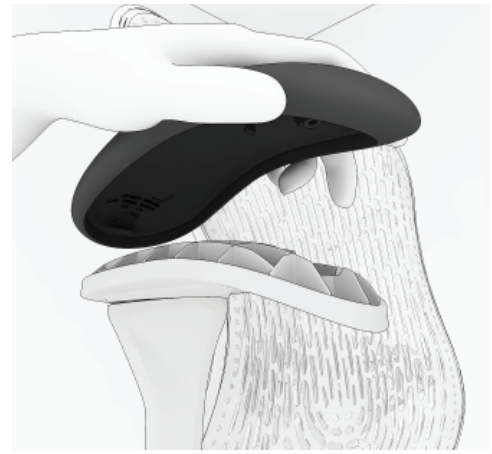

6. Lift up the arm pad and slide it off.

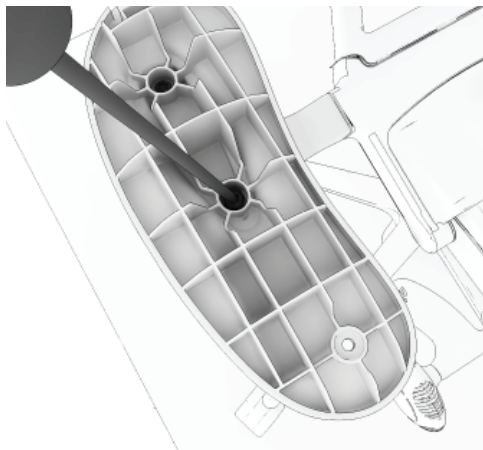

7. Using a T20 torx bit remove the two screws from the arm pad support plate.

Note: slide the arm pad support plate to gain access to the screw.

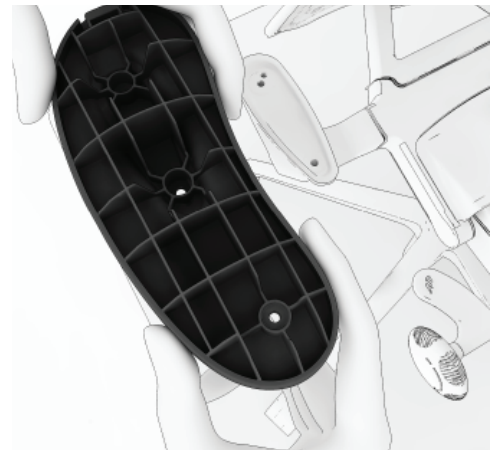

8. Arm Pad Support Plate removed.

Re-Assembly Steps:

4D Arm Pad Support Plate Installation



9. The 4D Arm Pad Support Plate is keyed. The key on the plate must match the key in the Arm Support.

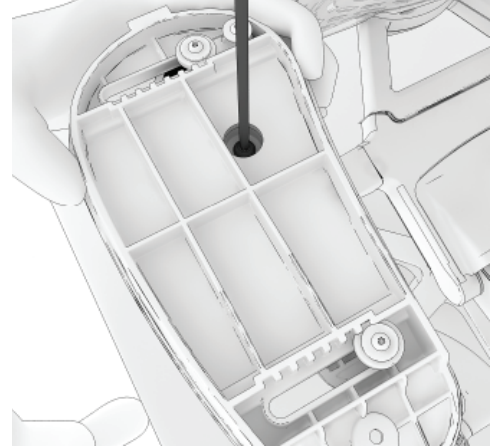

10. Reinstall the attachment bolt using T20 torx bit, tighten to 20 in/lbs

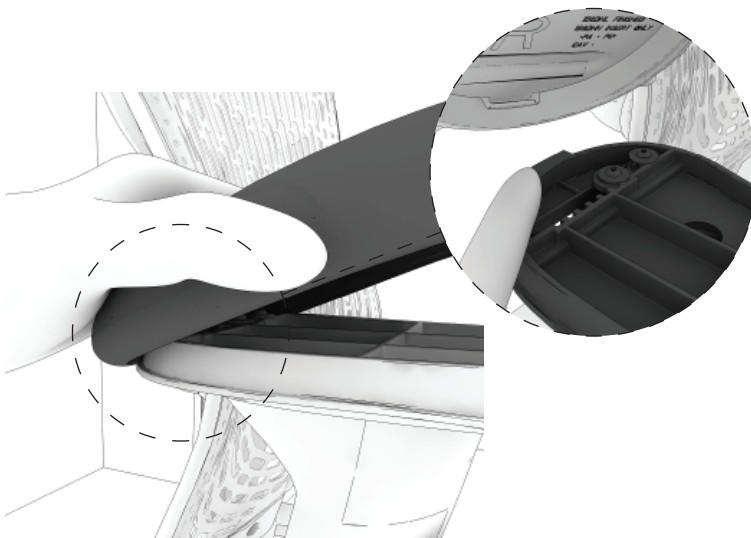

8. Hook the slot at the back of the arm pad into the tab on the arm plate and rotate the arm pad down.

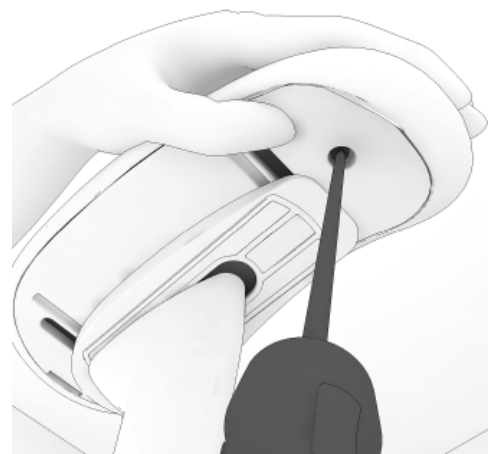

9. Torque to 15 in/lbs.

HermanMiller

Part no. 1BBSF4 rev D.

© 2014 Herman Miller, Inc. Zeeland, Michigan. Printed in the U.S.A.
©  Herman Miller, Mirra 2 are among the registered trademarks of Herman Miller, Inc.

Illustrations and specifications are based on the latest product information available at the time of publication. The right is reserved to make changes in design and specifications at any time, without notice, and also to discontinue products.

1D & Fixed Arm Pad Support Plate Installation

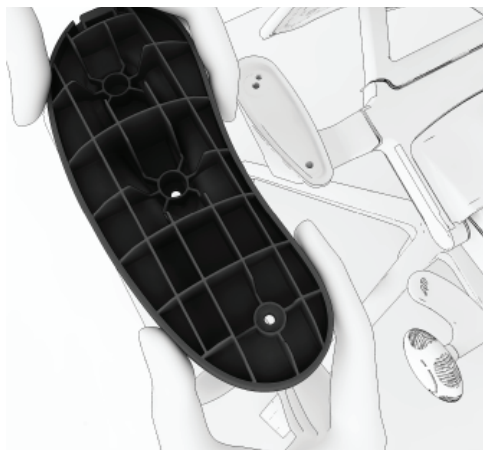

11. Position the arm plate.

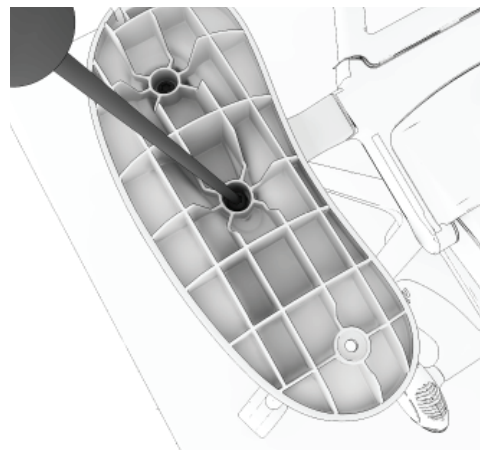

12. Reinstall the two screws and tighten to 20 in/lbs.

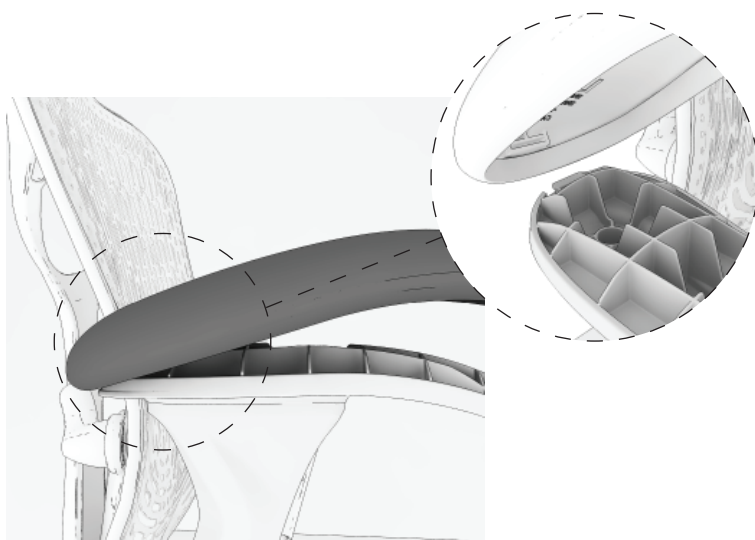

13. Hook the slot at the back of the arm pad into the tab on the arm plate and rotate the arm pad down.

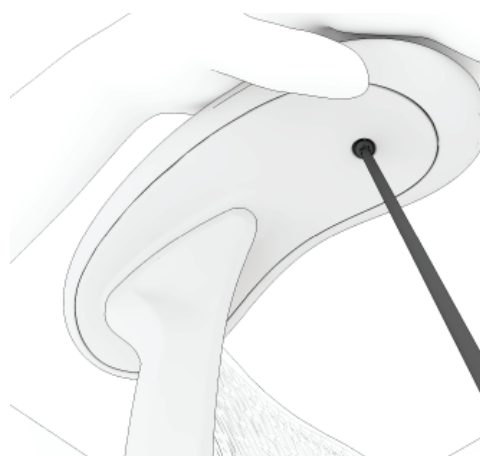

14. Torque to 15 in/lbs.

HermanMiller

Part no. 1BBSF4 rev D.

© 2014 Herman Miller, Inc. Zeeland, Michigan. Printed in the U.S.A.
©  Herman Miller, Mirra 2 are among the registered trademarks of Herman Miller, Inc.

Illustrations and specifications are based on the latest product information available at the time of publication. The right is reserved to make changes in design and specifications at any time, without notice, and also to discontinue products.



Parts Included:



Seat Depth Assembly

Tools Required:



Small Flat Head
Screw Driver

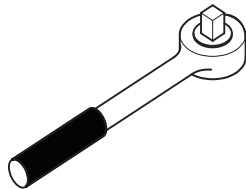

Ratchet Wrench

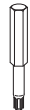

T40 Torx Bit



T25 Torx Bit

Steps:

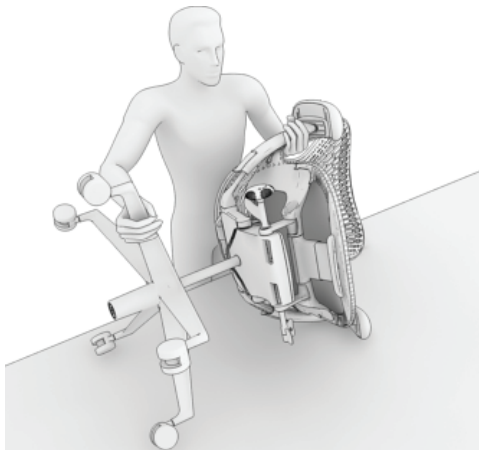

1. Lay chair on its side.

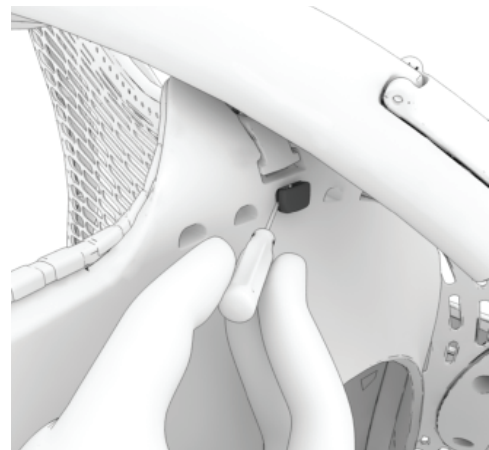

2. Remove the D-Plug from the retainer hole using the small screw driver. Repeat for the opposite side.

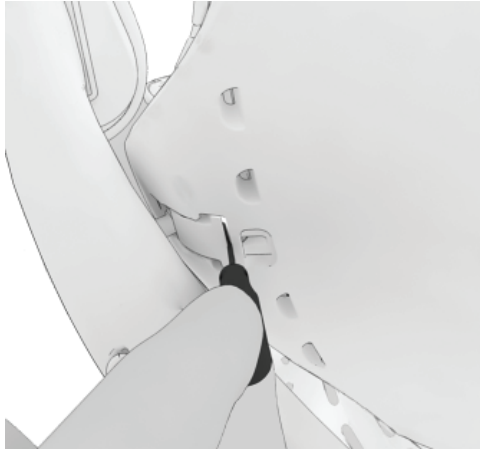

3. Slide the flat head screw driver into the slot and depress the spring clip.

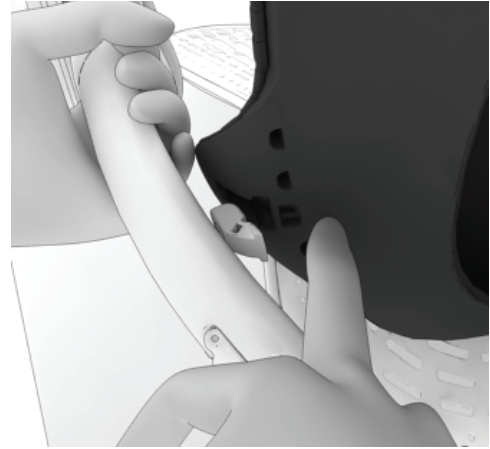

4. Lift upon the seat while depressing the spring clip. Repeat for the opposite side.

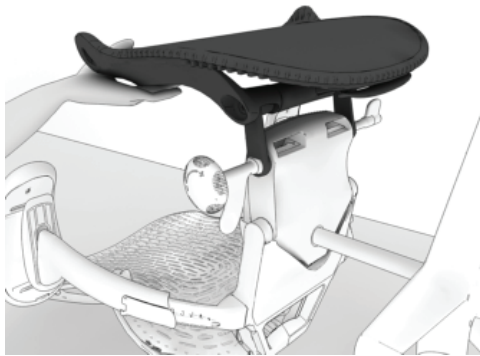

5. Make the seat loosen from the back.

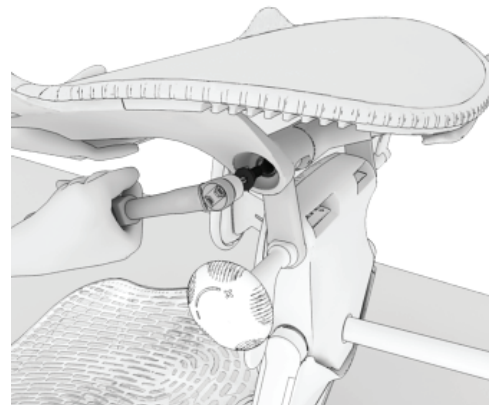

6. Using T40 torx bit remove the retainer bolt. Repeat for the other side.

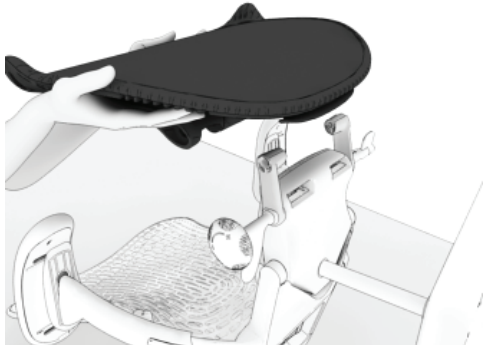

7. Remove the seat from chair.

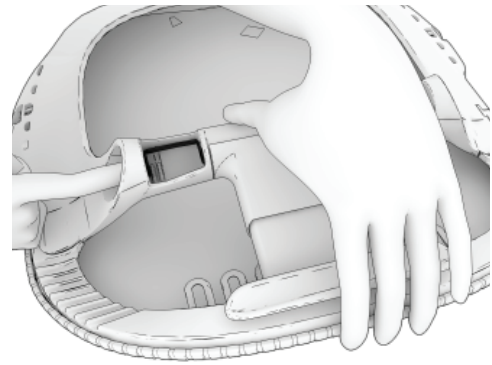

8. While compressing the seat depth mechanism push the bushing insert from the outside to remove.

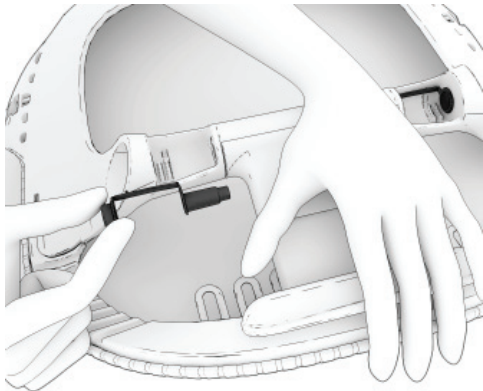

9. Carefully slide the seat link bushing from the seat depth mechanism and set aside. Repeat for opposite side.



10. Using a T27 torx bit remove the two screws from the seat depth mechanism.

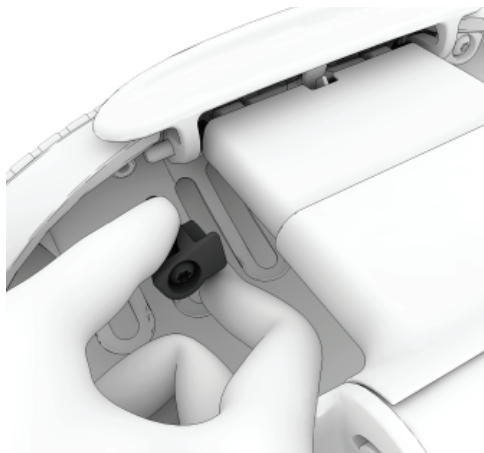

11. Remove the retainer caps.

Note: Caps are handed so note their original orientation before removing.



12. Remove seat depth mechanism from seat.

Re-assembly Steps:

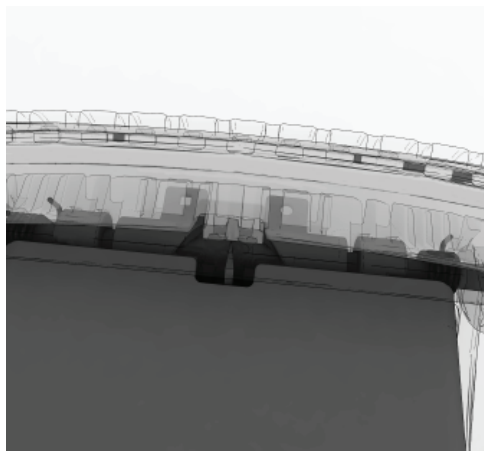

13. Locate the front edge first and the back edge in its position. Make sure the 2 little tabs engages to the white shelf at the bottom.

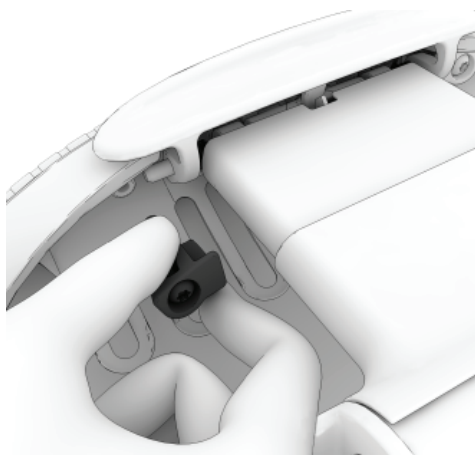

14. Install the retainer caps based on their original position and orientations.



15. Using T-27 torx bit install the two screws. Torque to 28 in/lbs.

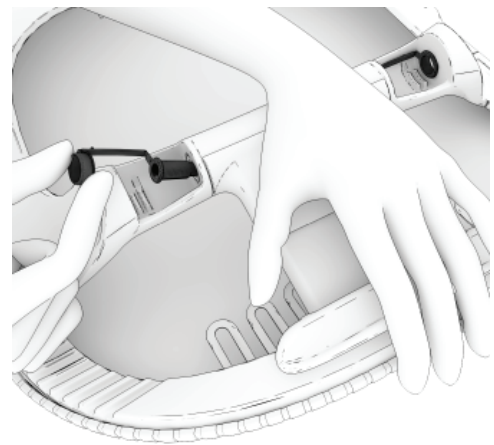

16. Position the back of the seat depth mechanism and compress to install the seat link bushings.

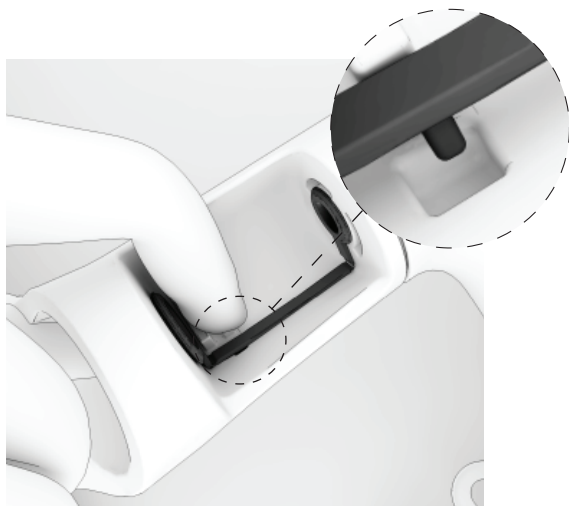

17. Make sure the tab on the bushing engages with the slot on seat frame.

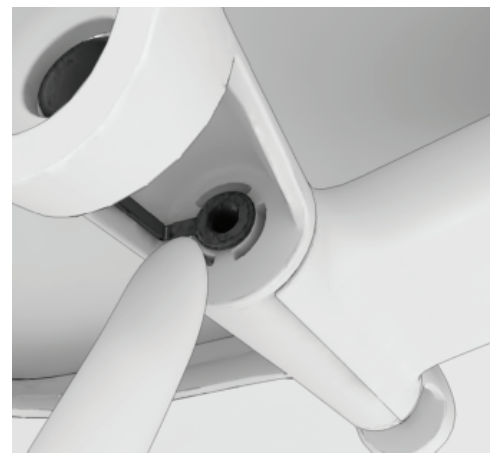

Note: Make sure the bushings are locked into the seat depth mechanism.

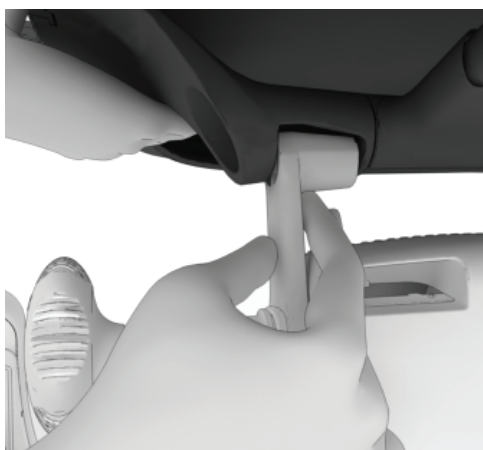

18. Rotate the seat down over the front links.

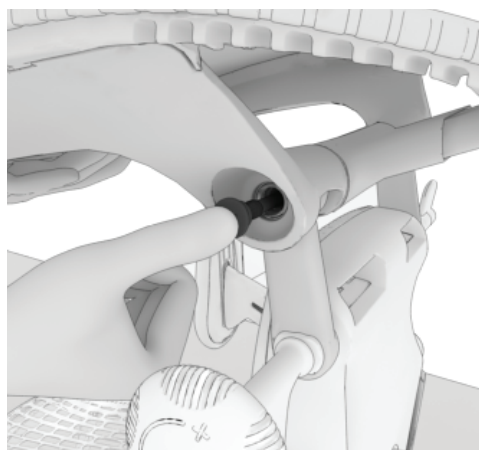

19. Install the bolts on both sides.

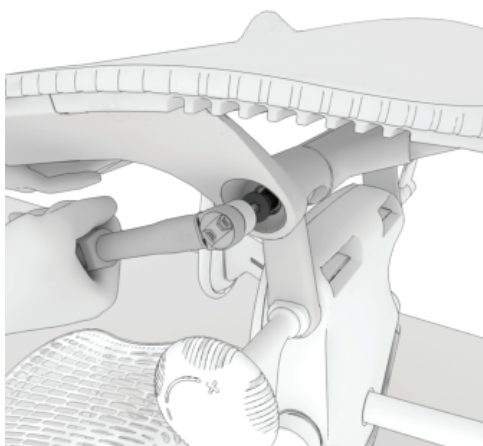

20. Using T40 torx bit, tighten the bolts to the torque to 300 in/lbs.

Caution: Do not over torque, you may strip the thread.

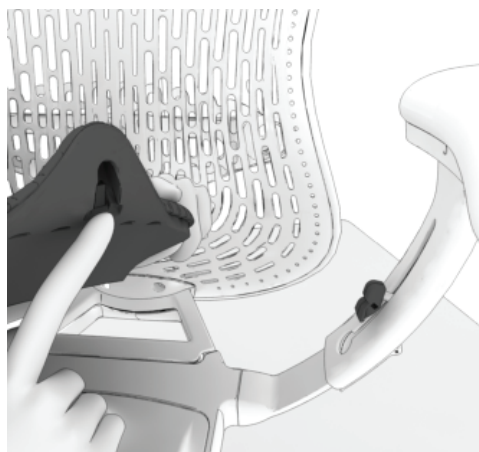

21. Rotate the seat to the end use position sliding the pivot bushing into the keyed opening in the seat.

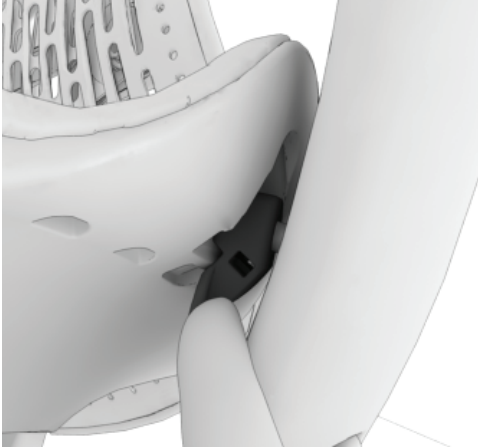

24. Push down until it snaps.
Repeat for the other side.

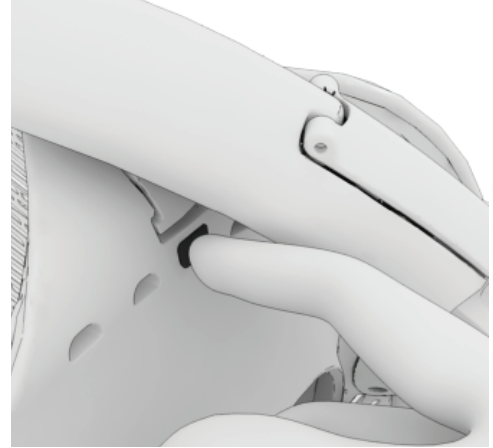

25. Instal the D-Clips into
seat. Repeat for the other
side.

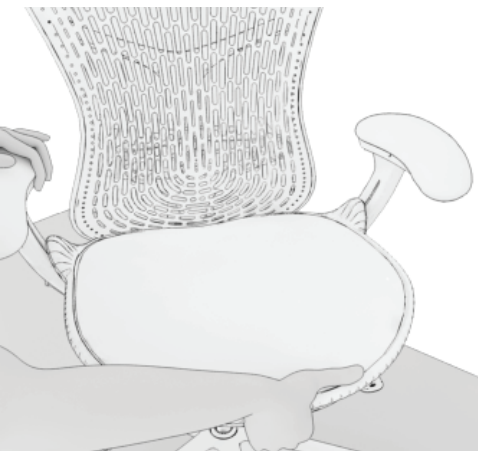

26. Check for proper function.



Parts Included:



Base

Tools Required:



Nylon Cap

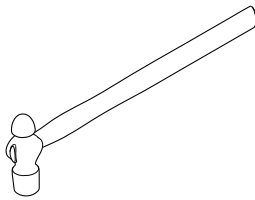

2lb Hammer

Steps:

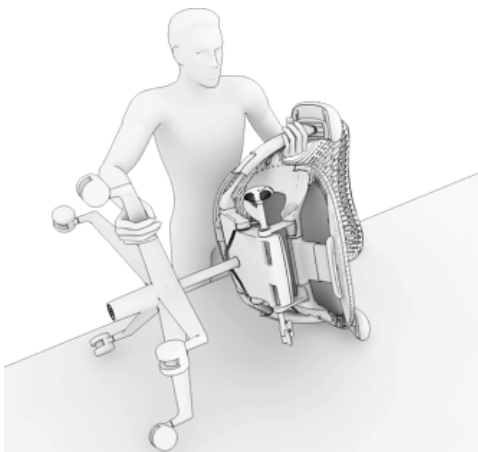

1. Lay chair on the side.

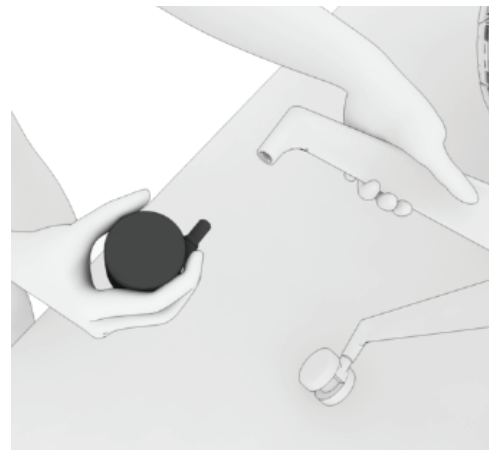

2. Remove all the casters and set aside for installation into the new base.

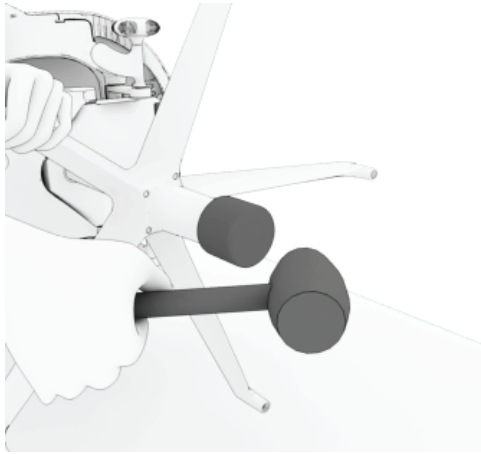

3. Place the nylon cap over the bottom of the cylinder. Strike the cap using a 2lb hammer to dislodge the base from the cylinder.

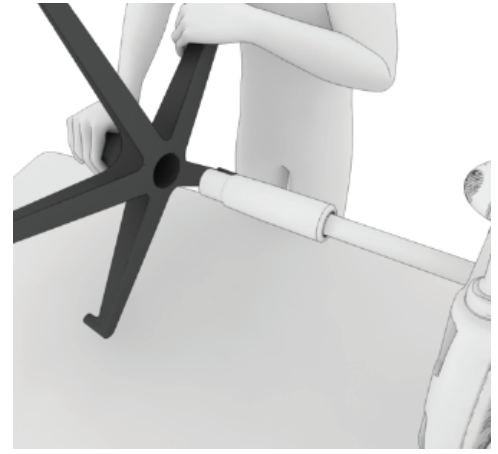

4. Remove the base from the cylinder.

Re-Assembly Steps:

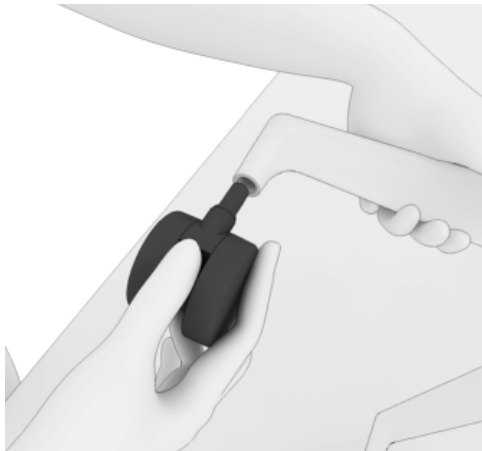

5. To reinstall the casters, place the thumb at the bottom of the caster and wiggle in until a audible click sound is heard.



6. Place the cylinder and seat assembly into the base.



7. Sit in the chair firmly several times to set the cylinder in the base.



Parts Included:



Cylinder

Tools Required:



Nylon Cap

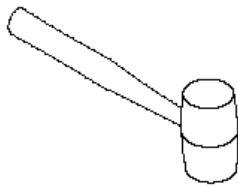

2#-3# Plastic Covered
Dead Blow Hammer

Note: Mirra 2 stool shown. For work chair omit footrest removal procedure.

Steps:



1. Lay chair on the side.

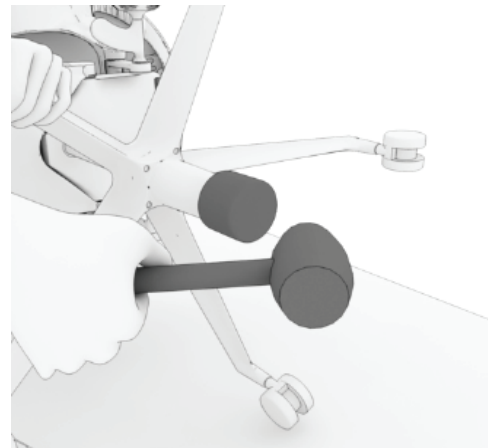

2. Place the nylon cap at the bottom of the cylinder. Using a dead blow hammer hit the bottom of the base.

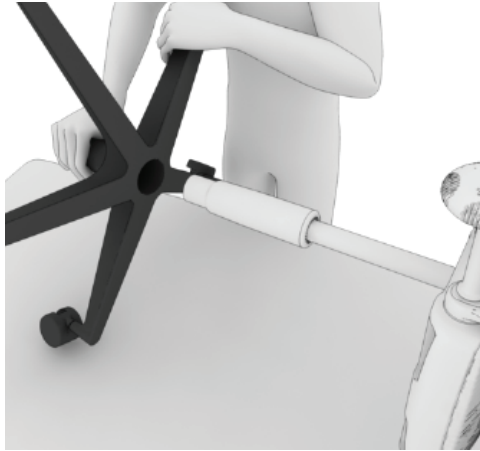

3. Remove base from the cylinder.



4. Remove footring from the cylinder.

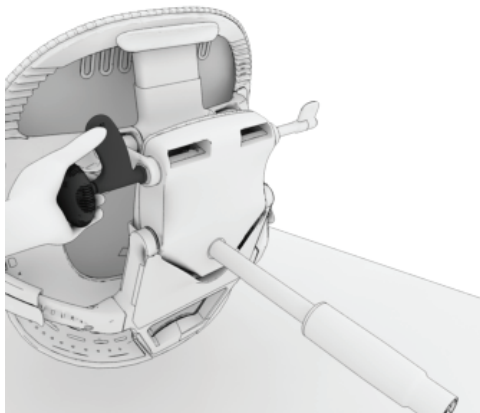

5. Rotate the height adjustment knob anti-clock wise to activate the cylinder.

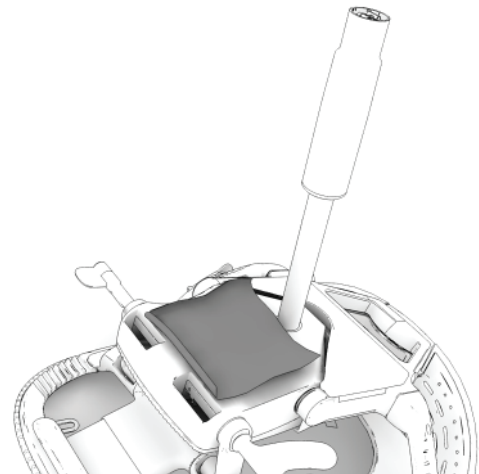

6. Place soft cloth onto tilt.

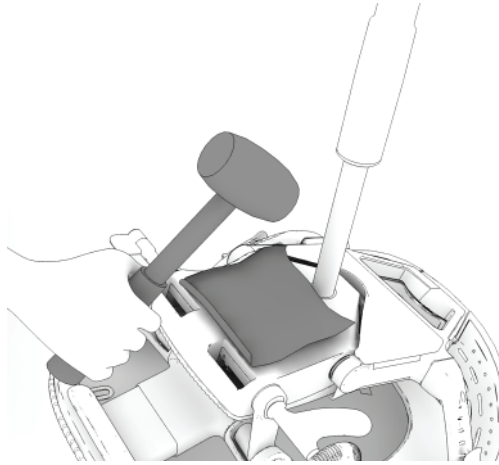

7. Strike the tilt with dead blow hammer back-and-forth on both sides until gas cylinder separates from tilt.

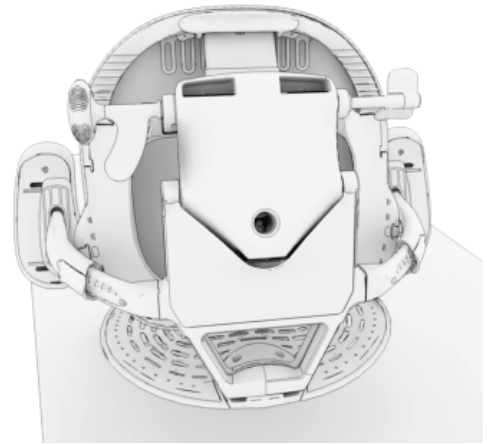

8. Remove the cylinder from the base.

Re-assembly Steps:



10. Install the new cylinder onto the base.

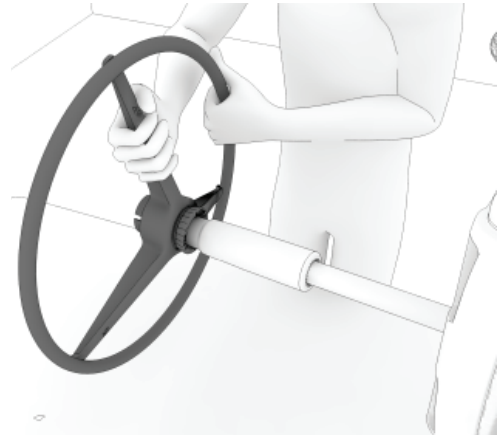

11. Install the footring into the cylinder.



12. Extend chair arms in upright position. Grab the arm stems and lower upper seat assembly onto top of cylinder.



13. Sit on chair firmly several times to set cylinder and base.



Parts Included:



Tilt Tension Control Knob



Tilt Limit Control Knob

Tools Required:



Small Flat Head
Screw Driver

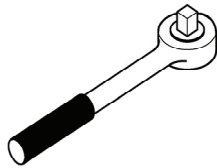

Ratchet Wrench
T40 torx bit



T27 Torx Bit



Flat Head Screw
Driver

Steps:

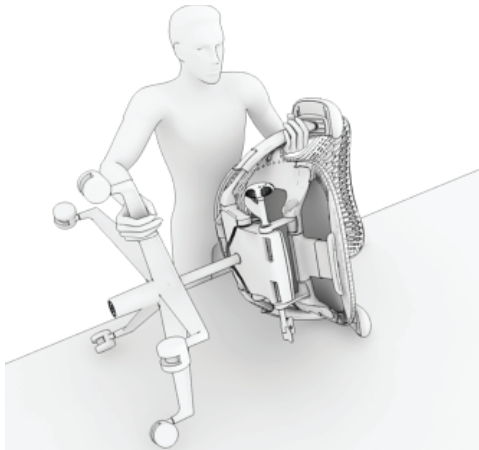

1. Lay chair on its side.

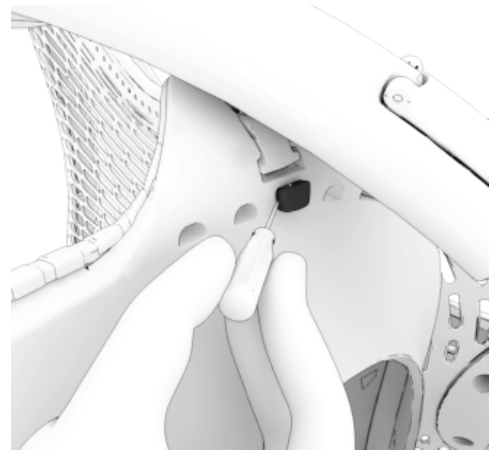

2. Remove the D-Plug from the retainer hole using the small screw driver. Repeat for the opposite side.

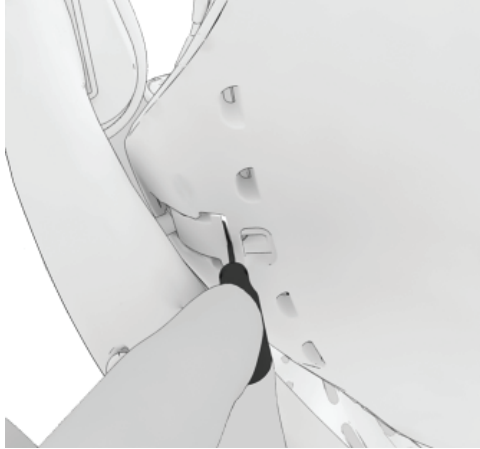

3. Slide the flat head screw driver into the slot and depress the spring clip.

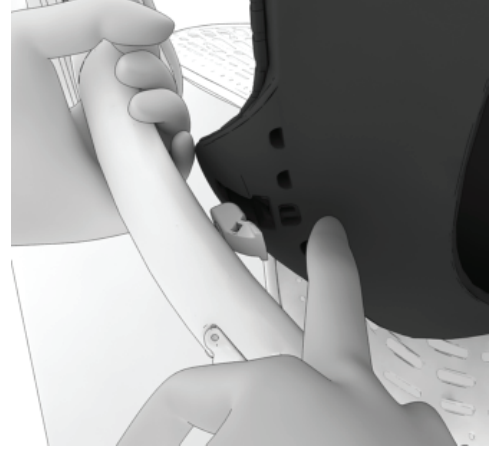

4. Lift upon the seat while depressing the spring clip. Repeat for the opposite side.

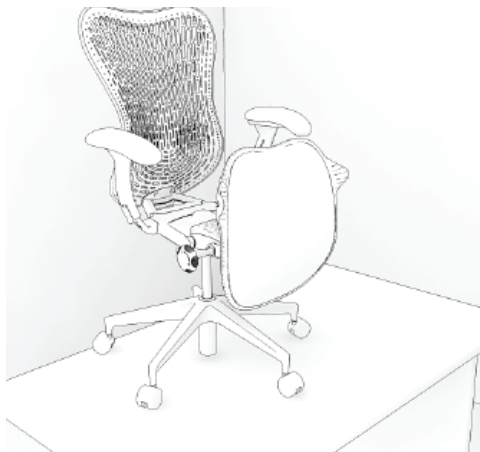

5. Stand the chair upright and roll the seat forward.

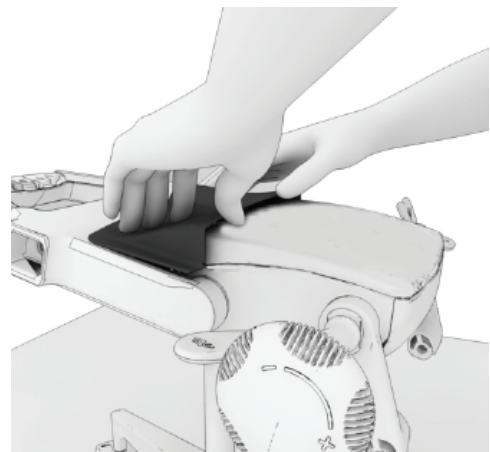

6. Using fingers remove rear tilt cover.

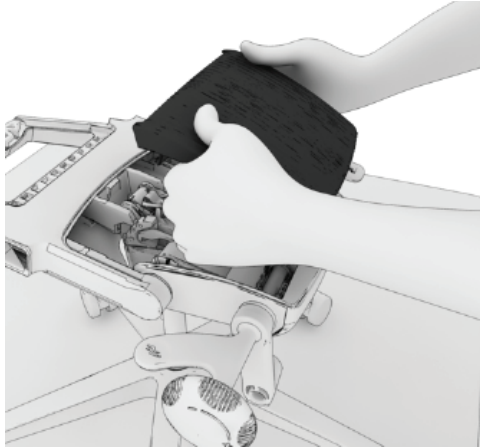

7. Remove the front tilt cover from tilt assembly.

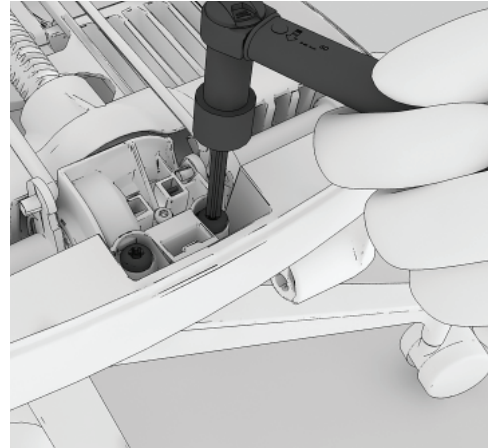

8. Using T25 torx driver remove the two screws from the control retainer.

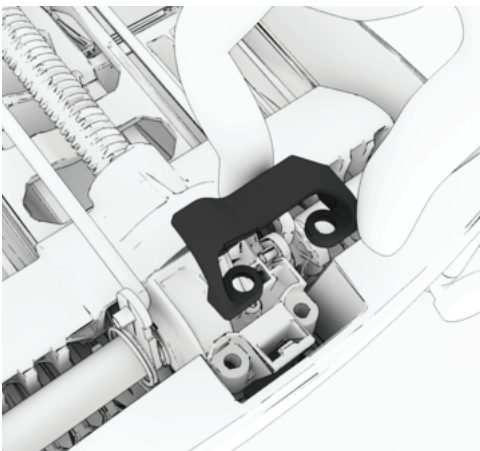

11. The control retainer is removed from the tilt assembly.

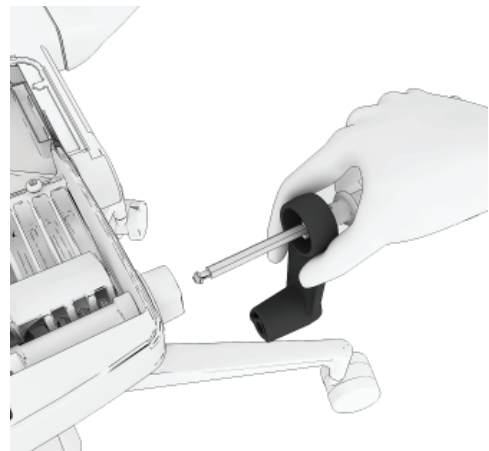

12. Pull the tilt limit control with front link and remove it from the tilt assembly.



13. Remove front link from tilt limit control.

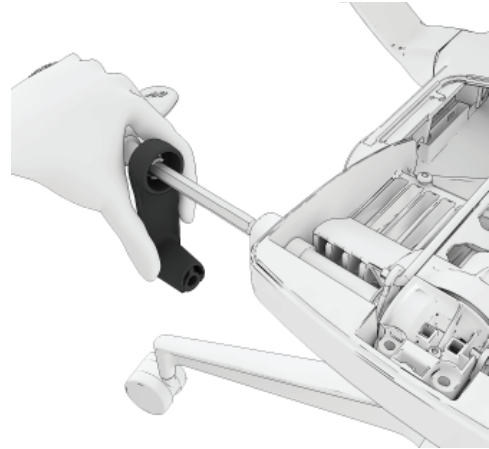

14. Pull the tilt tension control knob and remove it from the tilt assembly.



15. Remove the front link from tilt tension control.

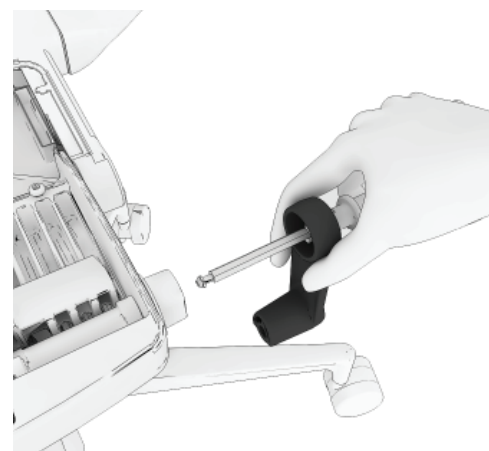

16. The tilt controls were removed from the tilt assembly.

Re-Assembly Steps:



17. Insert new front link into tilt tension height adjustment control knob assembly.

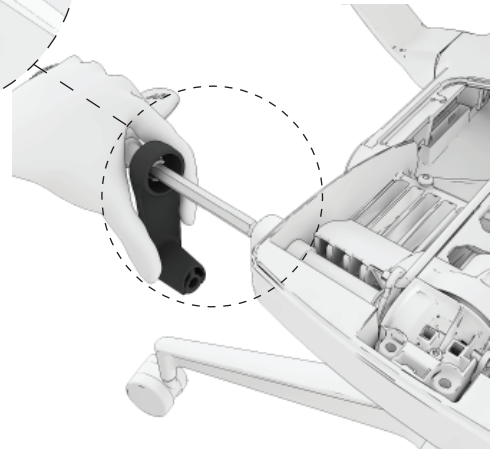

18. Install the tilt tension control knob with front link into tilt assembly.

Note: Height adjustment lever is keyed. AL16N keyed lever with mating part in tilt.



19. Insert new front link into tilt limit control assembly.

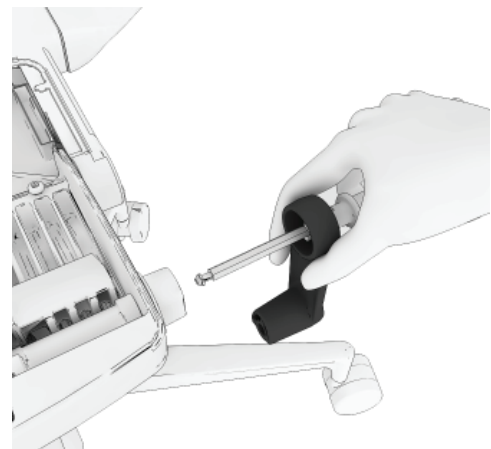

20. Install the tilt limit control assembly into the tilt assembly.

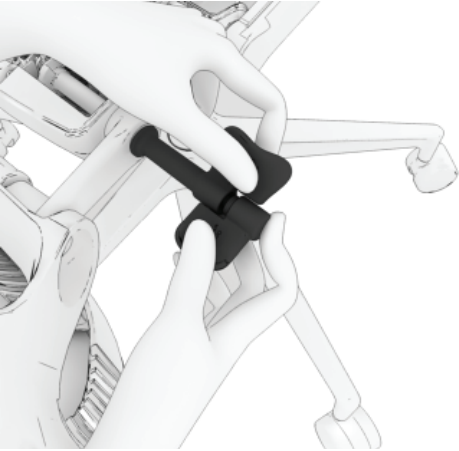

21. Slide the forward angle lever control knob over the rear tilt lever control knob.
Note: Rear tilt lever is keyed.
While applying pressure rotate them together until they snap into the tilt housing.

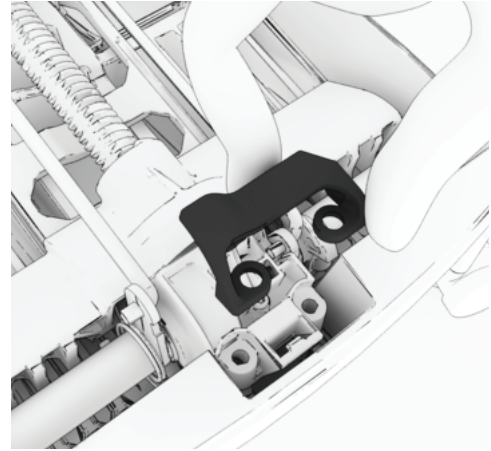

22. Install the control retainer into tilt assembly.

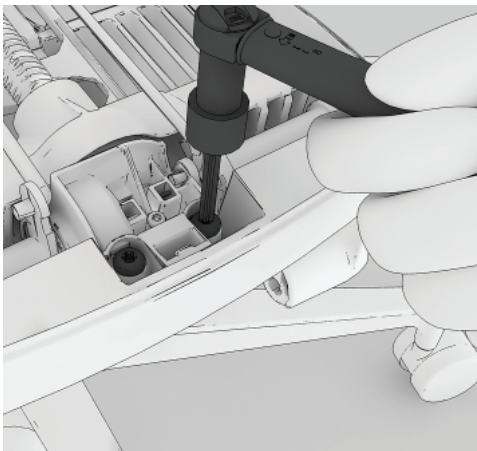

23. Using a T25 torx driver install the two screws.
Torque to 60 in/lbs. Check all levers for proper function.

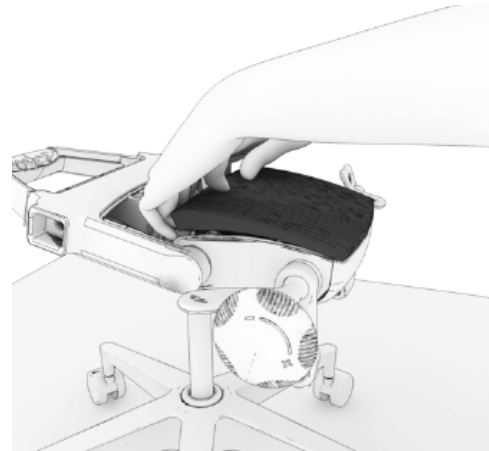

24. Position the top front tilt cover and snap it in place.

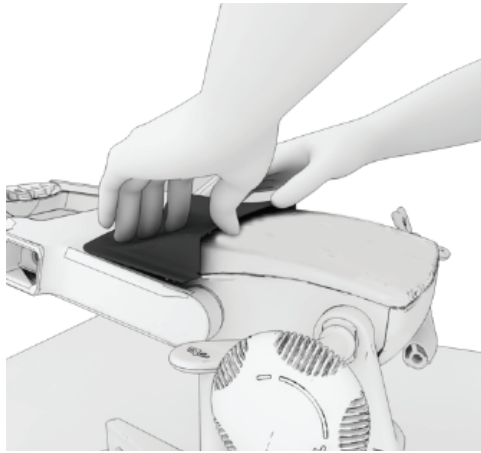

25. Position the rear tilt cover. Make sure it is snapped in place.

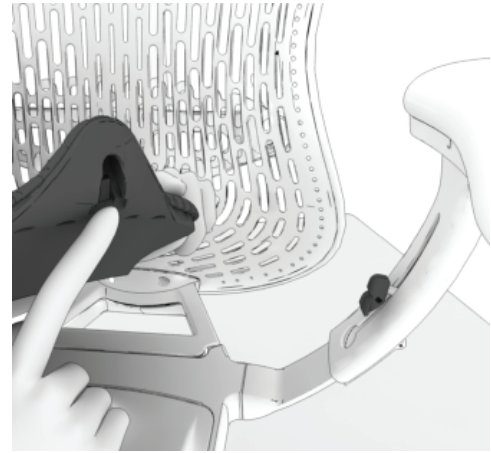

26. Rotate the seat to the end use position sliding the Pivot Bushing into the keyed opening in the seat.

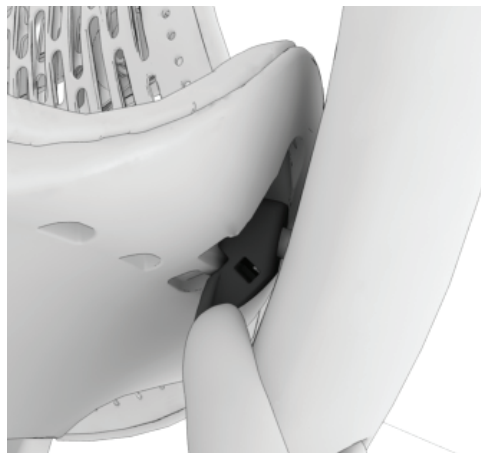

27. Push down until it snaps.

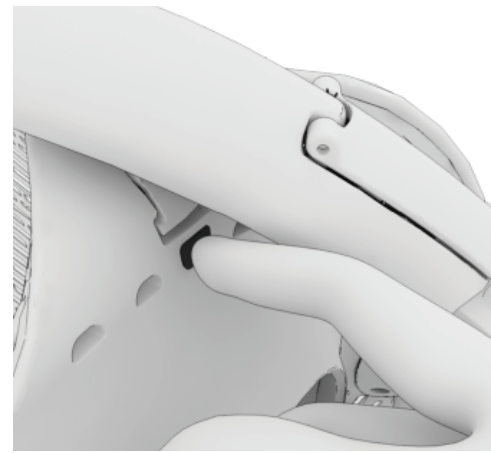

28. Instal D-Clips into seat. Repeat for the other side.

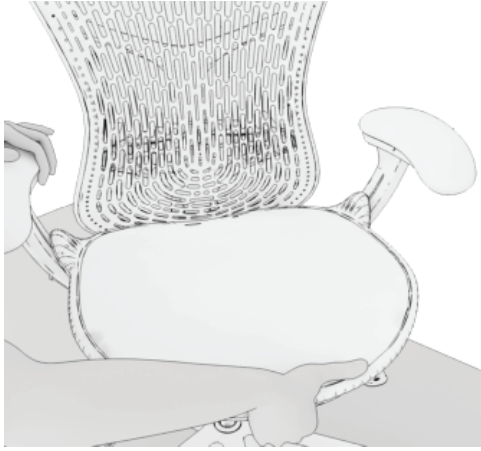

29. Check for proper function.



Parts Included:



Fixed Lumbar

Tools Required:



Philips Head
Screw Driver



Small Flat Head
Screw Driver

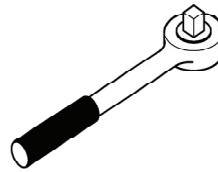

Ratchet Wrench



T27 Torx Bit

Steps:

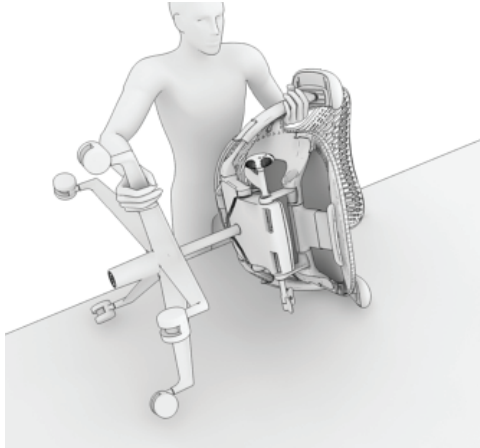

1. Lay the chair on its side.

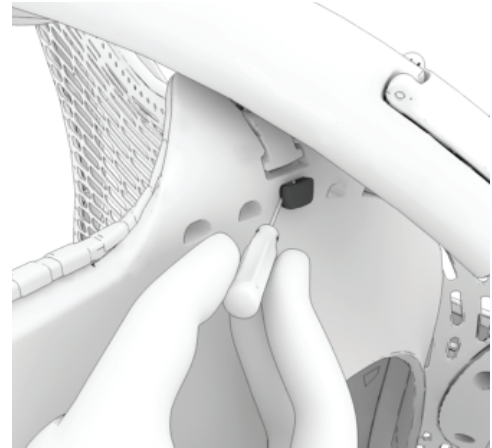

2. Remove the D-Plug from the retainer hole using the small screw driver. Repeat for the opposite side.

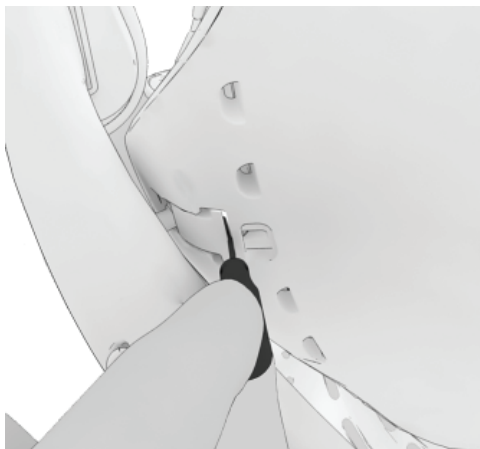

3. Slide the flat head screw driver into slot and depress the spring clip.

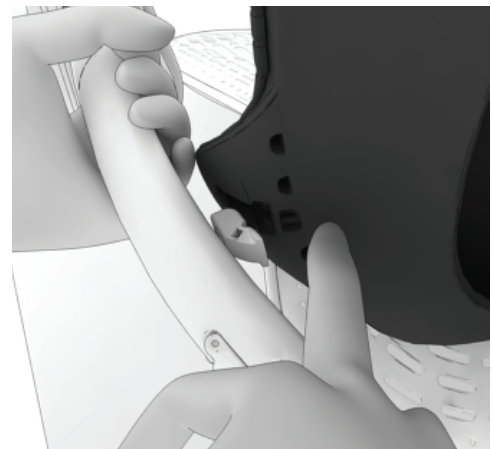

4. Lift up on the seat while depressing the spring clip. Repeat for the opposite side.



5. Stand the chair upright and roll the seat forward.

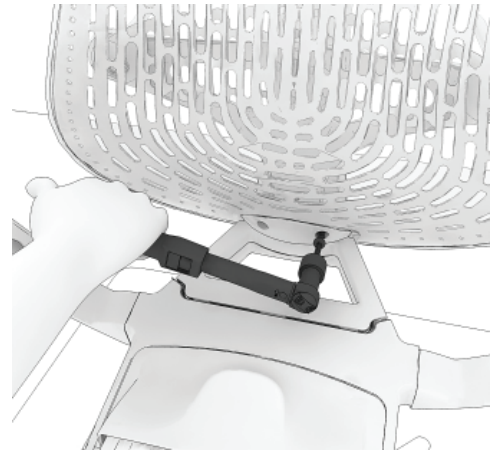

6. Use an extended 4 inch long T27 torx bit to remove the 2 screws at the bottom center of the back.

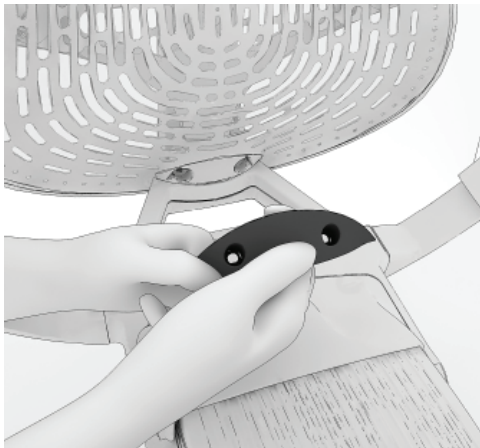

7. Remove the trim cover.

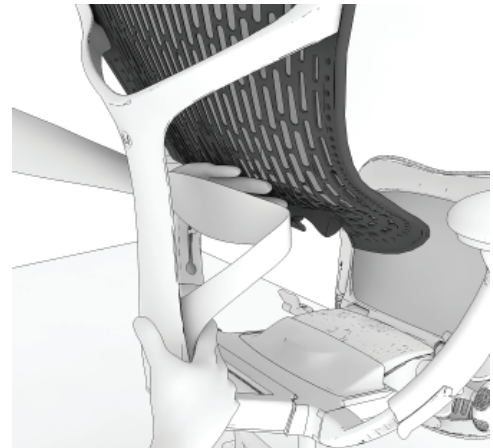

8. With only the bottom bolts removed flex the bottom of the back forward, away from the lumbar.

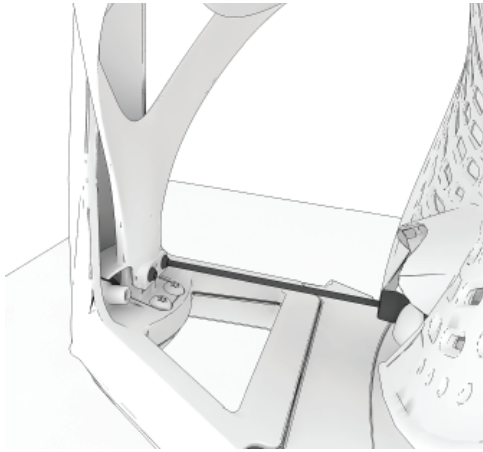

9. Using a T25 torx driver remove the two screws.

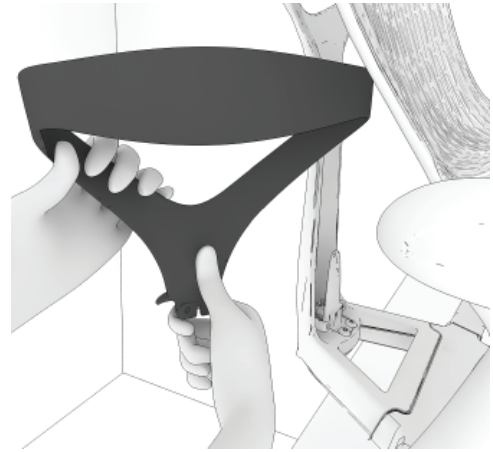

10. Slide the Lumbar up and off the stem.

Re-Assembly Steps:

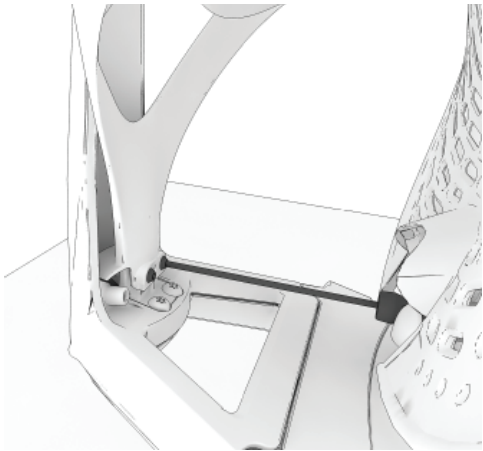

11. Install the new lumbar onto the stem and tighten the screws with T25 torx driver. Torque to 70 in/lbs.

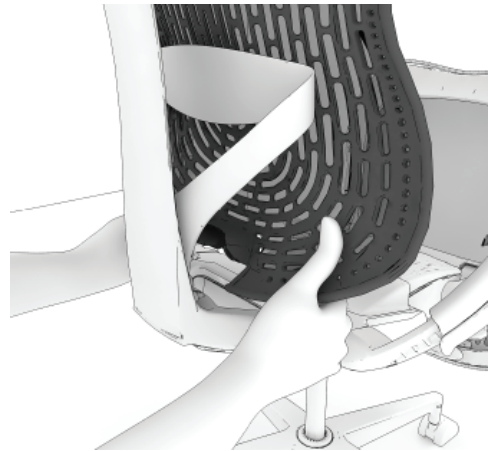

12. Flex the Back and slide around the bottom of the spine.

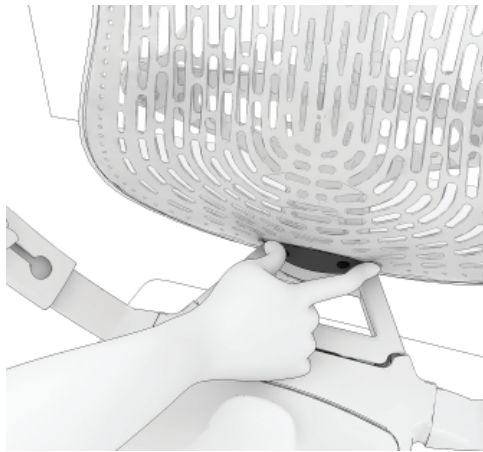

13. Reinstall the trim cover.

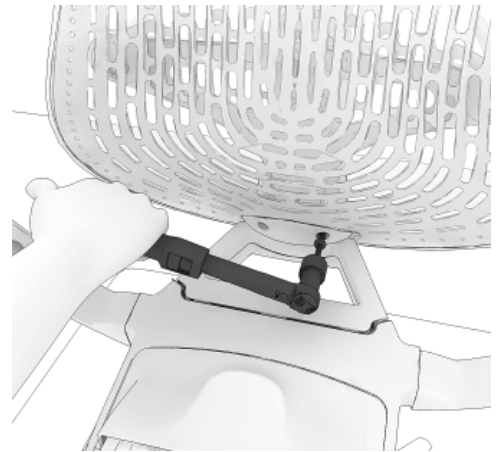

14. Reinstall the bolts using the extended T27 torx bits. Torque to 70 in/lbs.

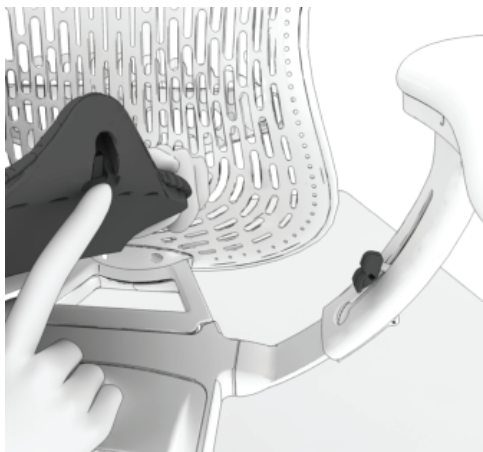

15. Rotate the seat to the in use position sliding the Pivot Bushing into the keyed opening in the seat.

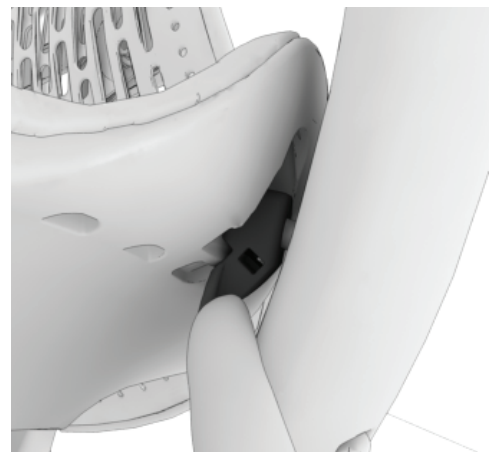

16. Push down until it snaps.

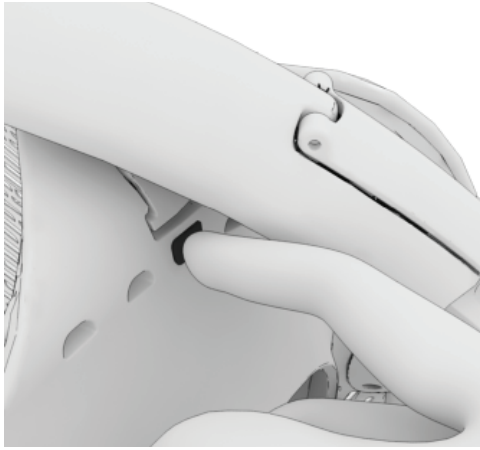

17. Reinstall D-Clips.

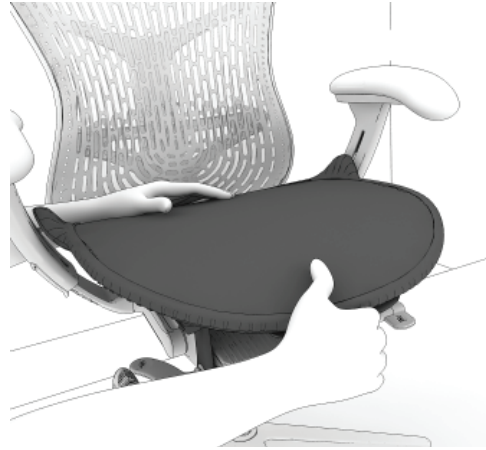

18. Check for proper function.



Parts Included:



Arm Support Casting

Additional notes:

New Style Arm Support Post Implemented 9/2016



Old Style



New Style

Tools Required:

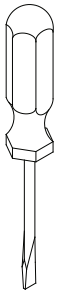

Small Flat Head
Screw Driver

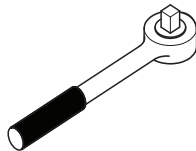

Ratchet Wrench



4" T30 Torx Bit



13mm deep Socket

Steps:

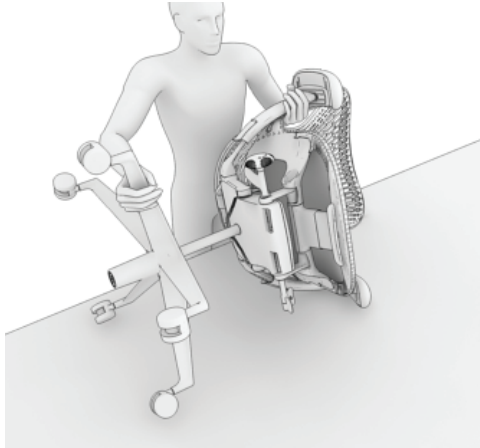

1. Lay the chair on its side.

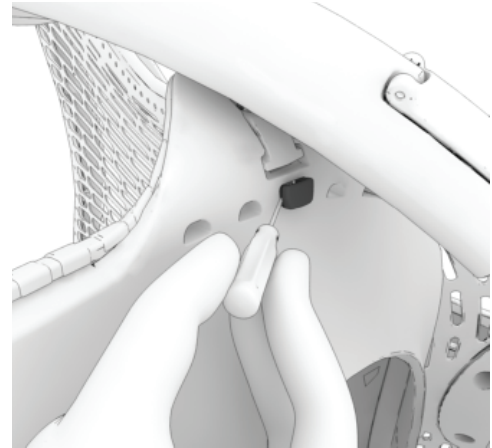

2. Remove the D-Plug from the retainer hole using the small screw driver. Repeat for the opposite side.

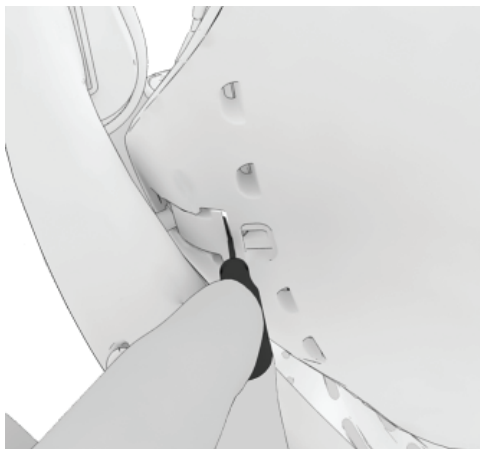

3. Slide the flat head screw driver into slot and depress the spring clip.

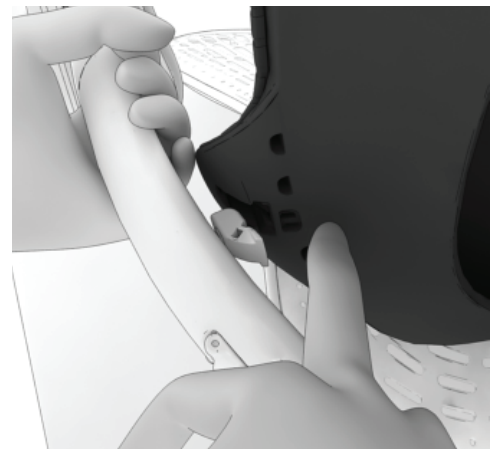

4. Lift upon the seat while depressing the spring clip. Repeat for the opposite side.



5. Stand the chair upright and roll the seat forward.

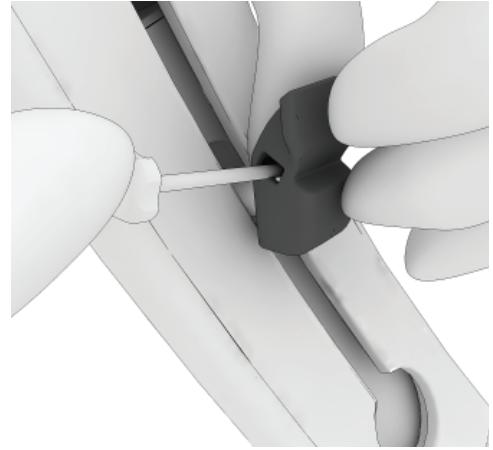

6. Rotate the Hip Pivot Bushing upside down. Insert the flathead screw driver into the hole and release the tab by depressing the clip.

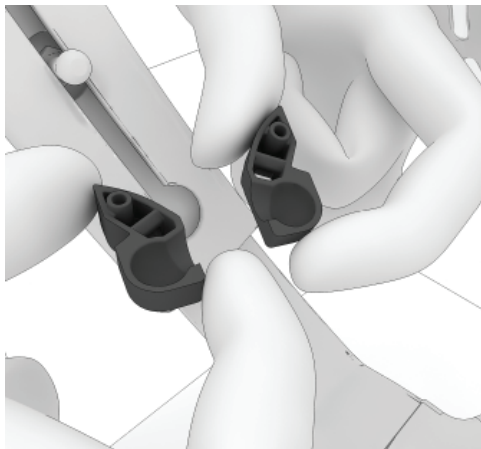

7. Hip Pivot Bushing removed.



8. Align the keyed hole in the arm with the arm support post.

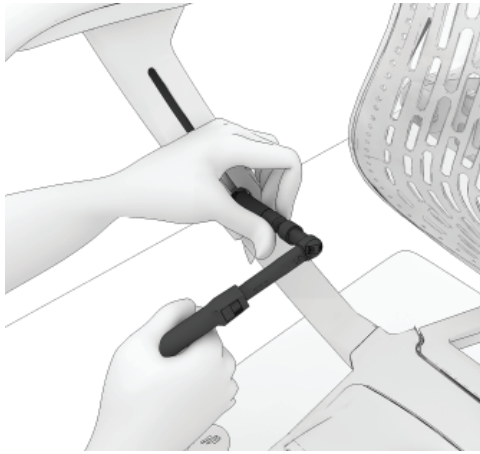

9. Using 13mm deep socket remove the Arm Support Post.



10. Arm Support Post removed.



11. Remove the washer from arm. New Arm Support Post does not use washer.

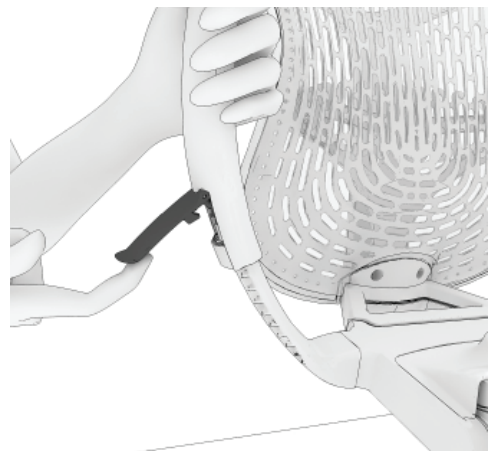

12. Release the catch on the arm.

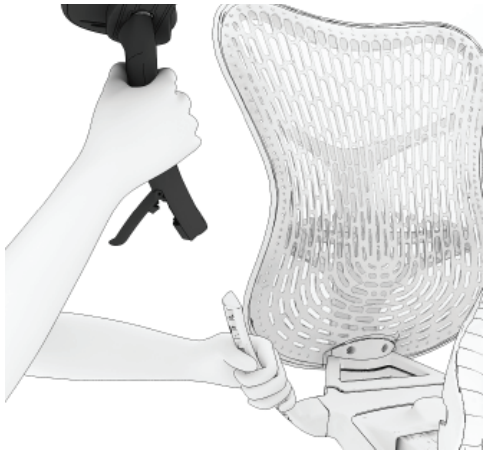

13. Slide the entire assembly up to remove the arm.

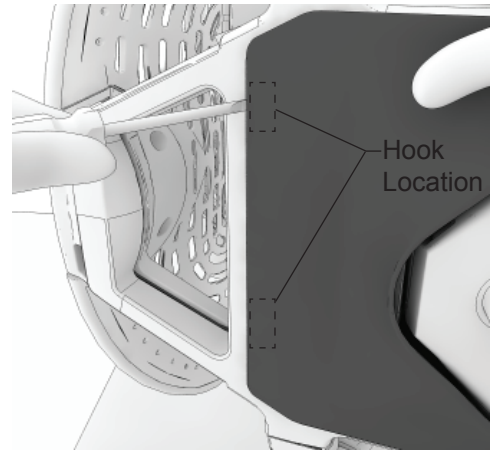

14. Using a small flat head screwdriver depress the two hooks in the back of the bottom tilt cover as shown. Remove the tilt cover.

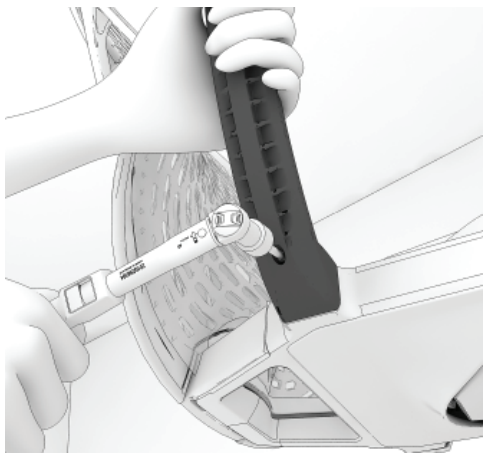

15. Use 6" T40 torx bit to remove the arm casting from tilt assembly.



16. While loosening the bolt pull the arm away from the housing and remove the bolt from arm casting.

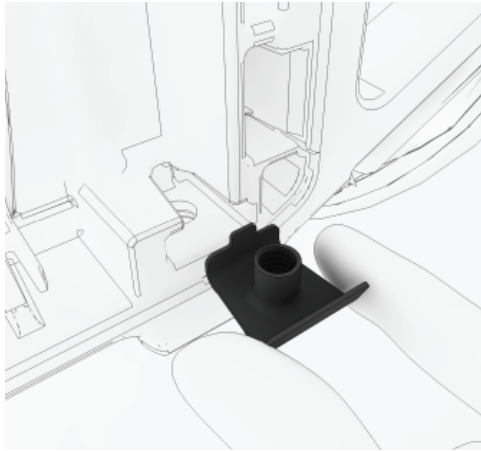

17. Remove the nut plate from the bottom of the tilt assembly.

Re-Assembly Steps:

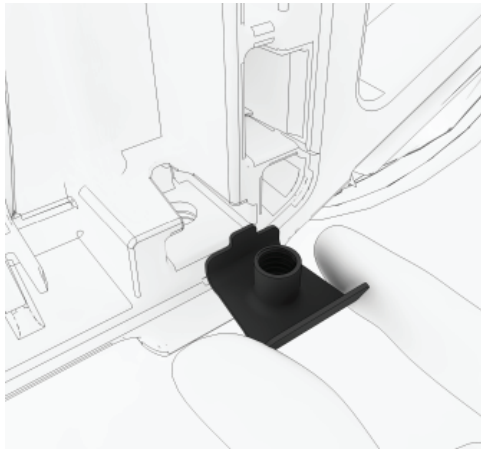

18. Place the nut plate on the bottom of the tilt assembly.

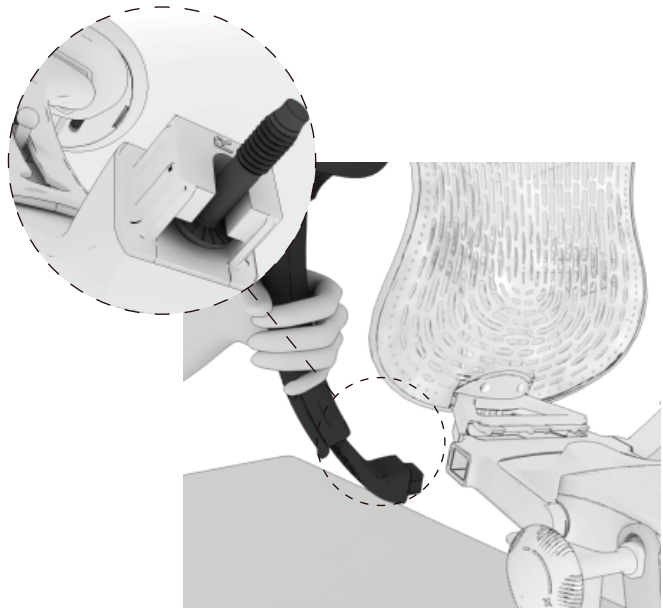

19. Place the bolt into arm casting slot.

Note: Arm castings are handed L + R

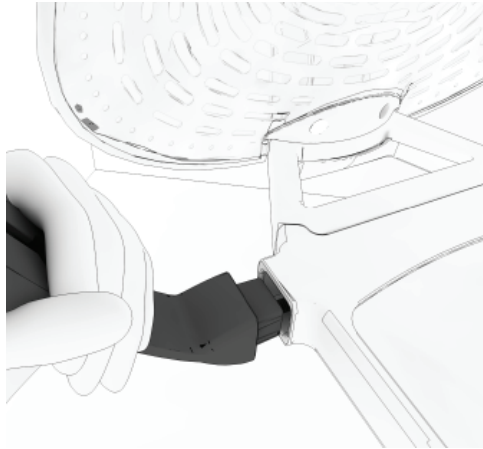

20. Position the arm in place.

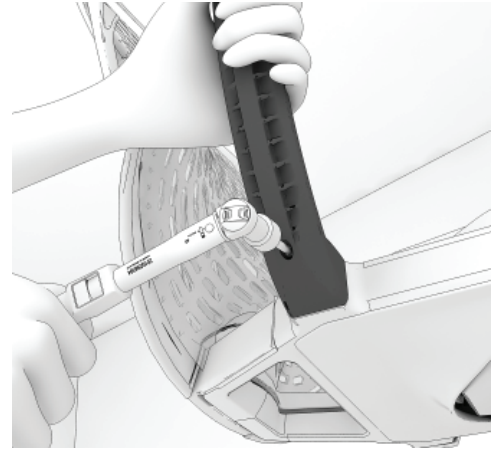

21. Using a 6" T40 torx bit tighten the bolt to 330 in/lbs.

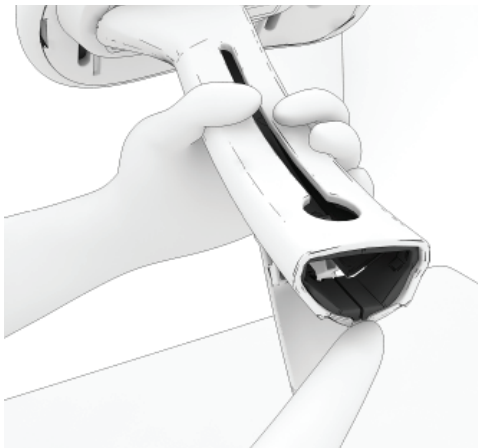

22. While re-installing the arm assembly make sure the plastic bearing is seated inside the arm. It may be extended out.

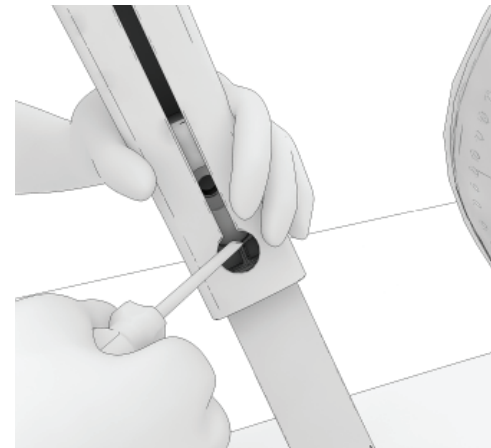

23. Using flat head screw drive slide the sleeve back down if it is not in properly seated.

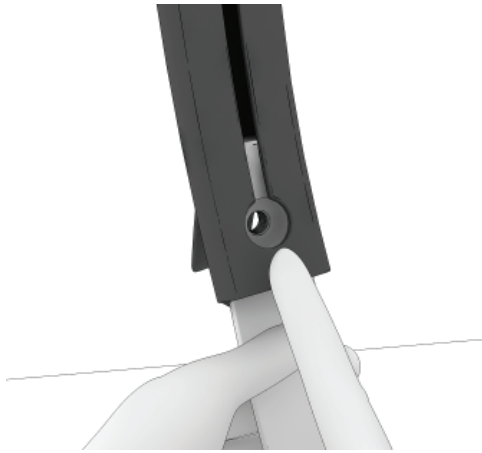

24. Align the opening in the arm up with the hole in the arm support casting.



25. Install the washer into arm. New Arm Support Post does not use washer.

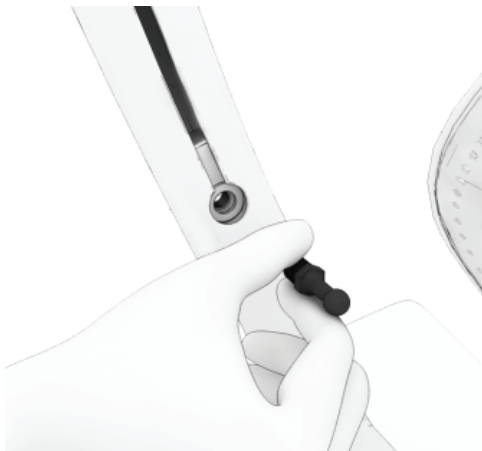

26. Hand start the Arm Support Post.

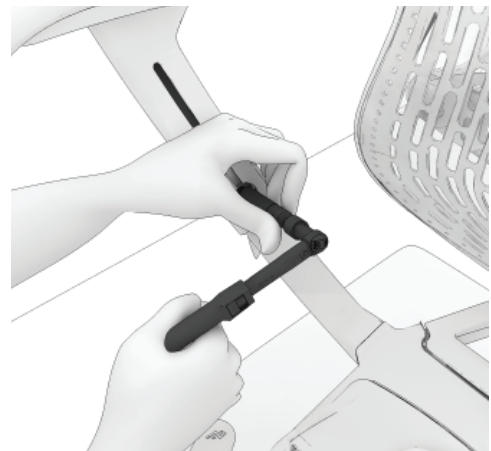

27. Using a 13mm deep socket tighten the Arm Support Post. Torque to 300 in/lbs.

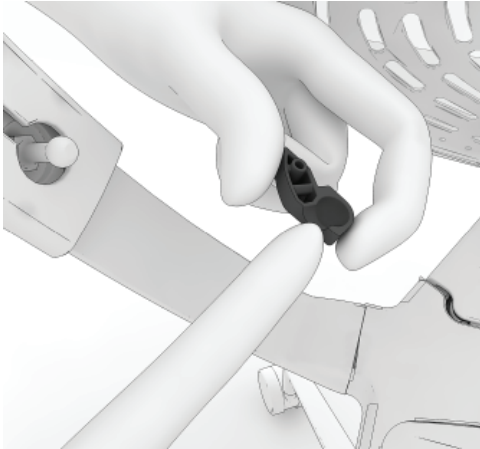

28. Install the new Hip Pivot Bushing on the ball end of the Arm Support Post.

Note: The bushing will only go on one way.

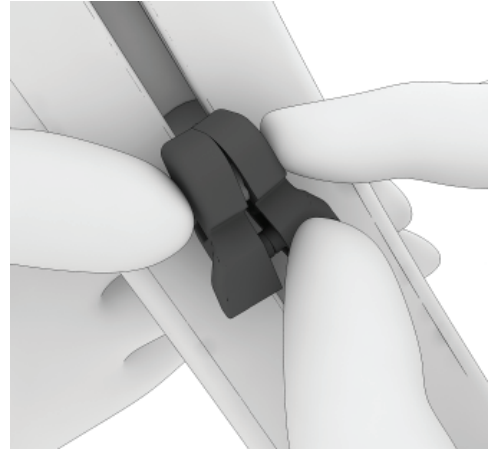

29. Snap the two halves of the Hip Pivot Bushing together.

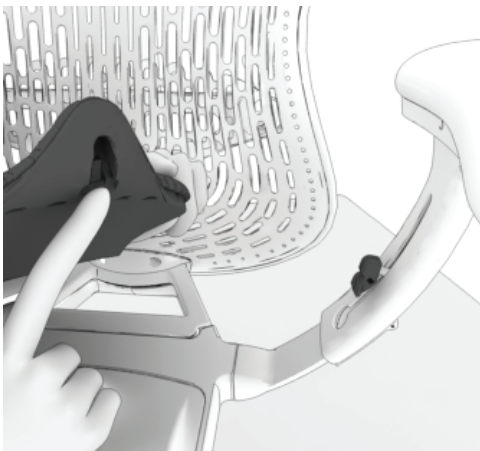

30. Rotate the seat to the end use position sliding the Pivot Bushing into the keyed opening in the seat.

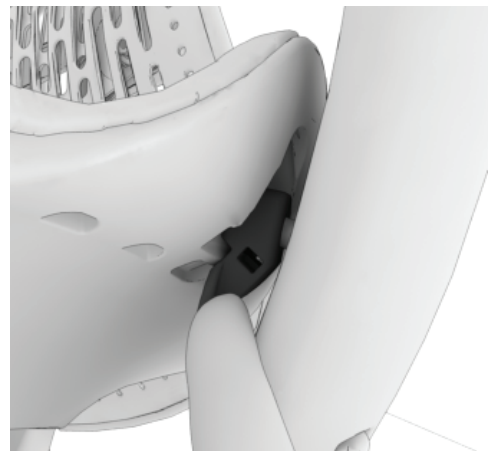

31. Push down until it snaps.

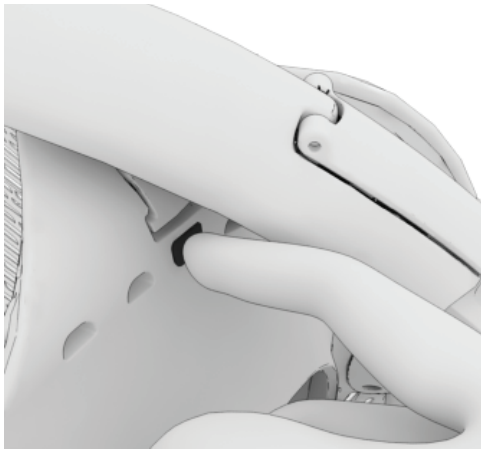

32. Reinstall D-Clips.

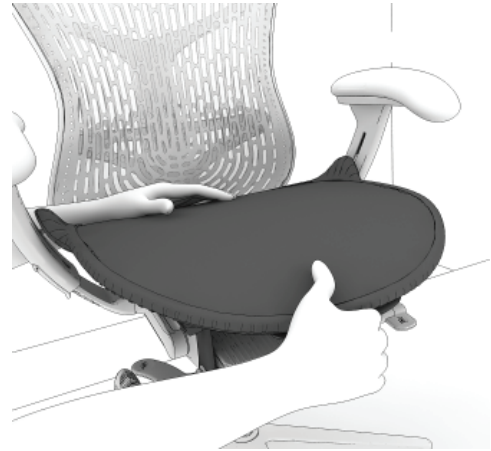

33. Check for proper function.



Mirra 2® Sleeve Bearing Replacement Hip Pivot Retainer/ Hip Pivot Bushing/ Arm Stem Sleeve

Parts Included:



Plastic Sleeve Bearing



Hip Pivot Bush



Hip Pivot Retainer

Additional notes:

New Style Arm Support Post Implemented 9/2016



Old Style



New Style

Tools Required:

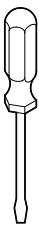

Small Flat Head
Screw Driver

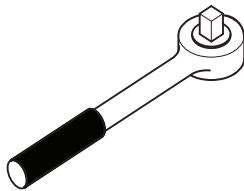

Ratchet Wrench



T40 Torx Bit



13mm deep Socket

Hip Pivot Retainer Replacement:

Steps:

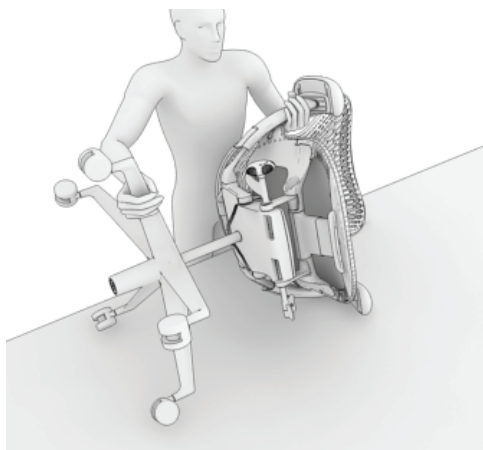

1. Lay the chair on its side.

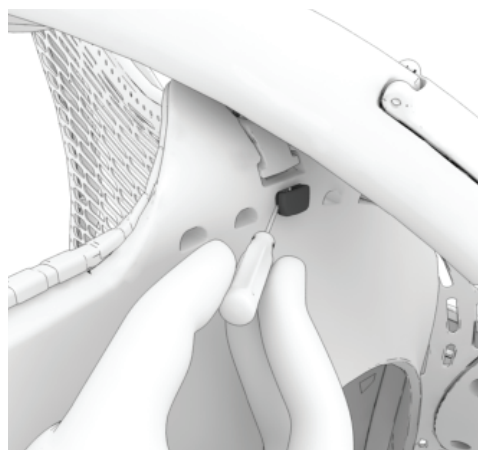

2. Remove the D-Plug from the retainer hole using the small screw driver. Repeat for the opposite side.

Re-Assembly Steps:



3. Install new D-Plug. Repeat it for the other side

HermanMiller

Part no. 1BBT3J rev D

© 2016 Herman Miller, Inc. Zeeland, Michigan. Printed in the U.S.A.
©  Herman Miller, Mirra 2 are among the registered trademarks of Herman Miller, Inc.

Illustrations and specifications are based on the latest product information available at the time of publication. The right is reserved to make changes in design and specifications at any time, without notice, and also to discontinue products.

Hip Pivot Bushing Replacement:

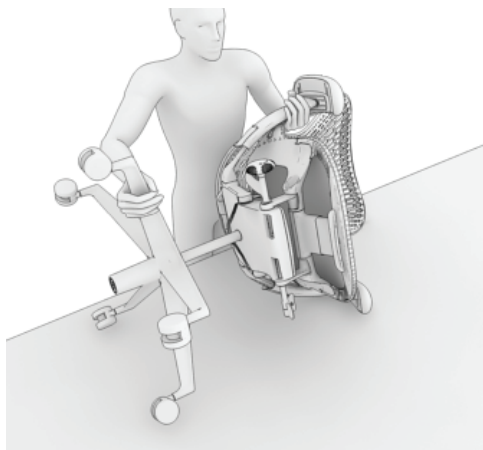

1. Lay the chair on its side.

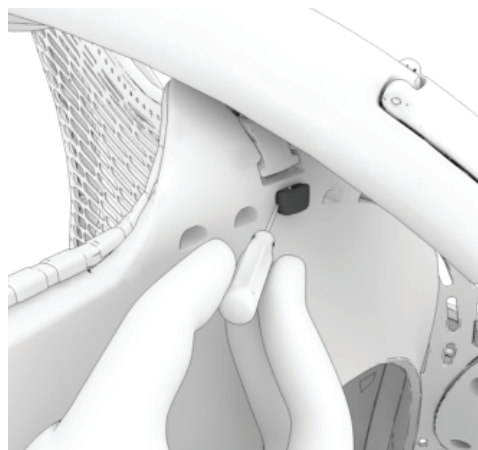

2. Remove the D-Plug from the retainer hole using the small screw driver. Repeat for the opposite side.

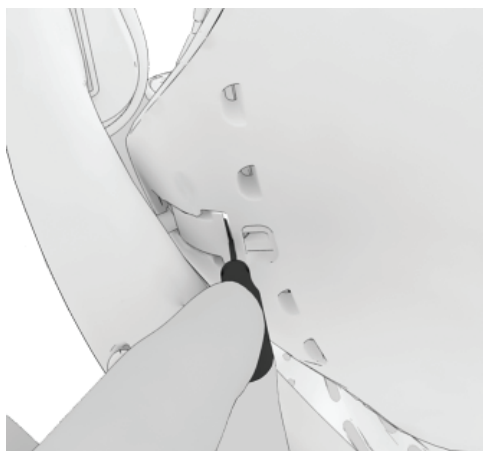

3. Slide the flat head screw driver into slot and depress the spring clip.

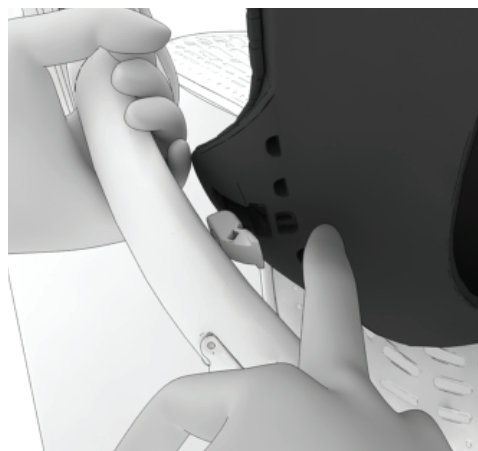

4. Lift upon the seat while depressing the spring clip. Repeat for the opposite side.



5. Roll the seat forward.

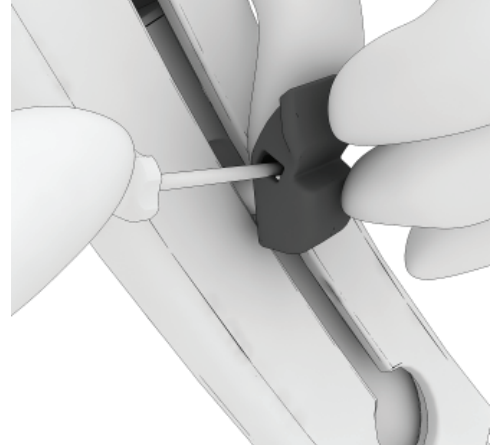

6. Rotate the Hip Pivot Bushing upside down. Insert the flat head screw driver into the hole and release the tab by depressing the clip.

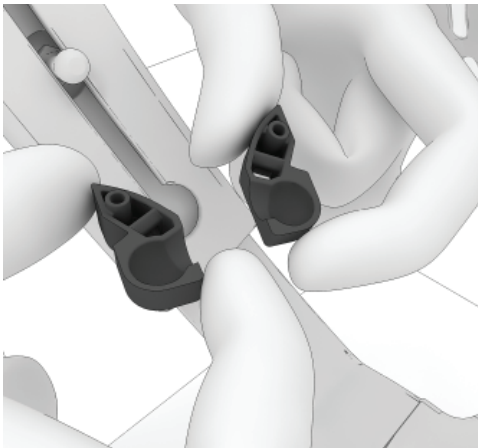

7. Hip Pivot Bushing removed.

Re-Assembly Steps:

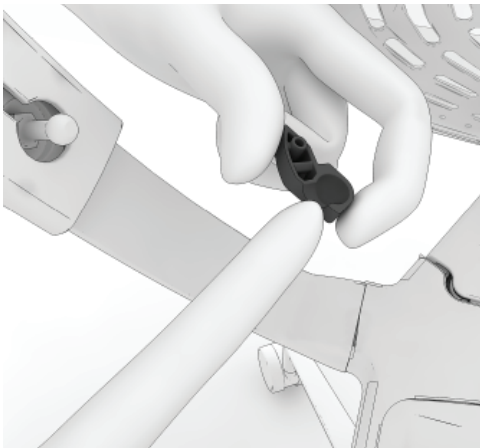

8. Install the new Hip Pivot Bushing on the ball end of the Arm Support Post. Note: The bushing will only go on one way.

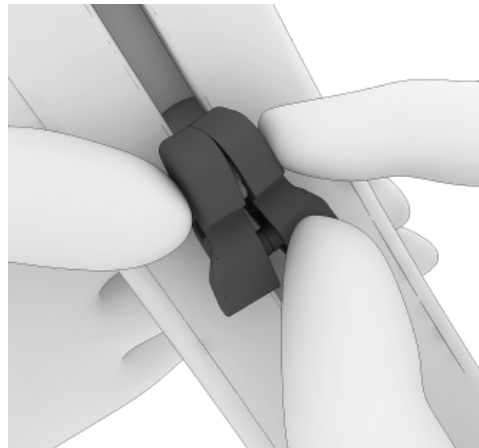

9. Snap the two halves of the Hip Pivot Bushing together.

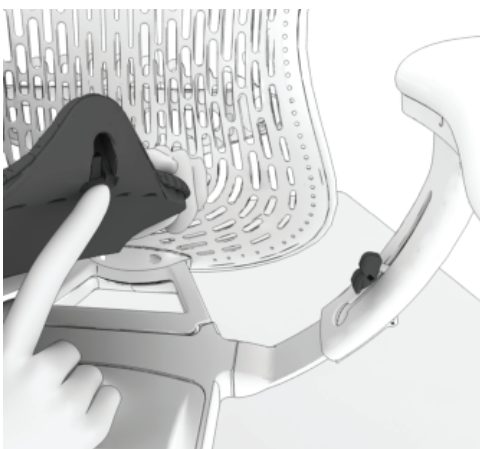

10. Rotate the seat to the in use position sliding the Pivot Bushing into the keyed opening in the seat.

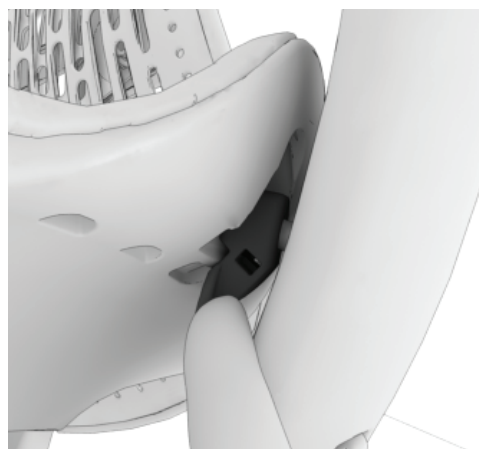

11. Push down until it snaps.

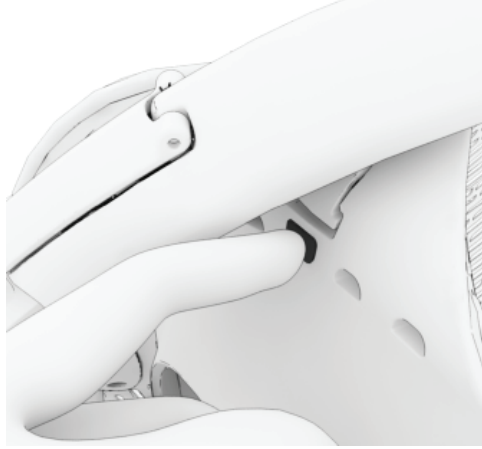

12. Reinstall D-Clips.



13. Check for proper function.

Arm Stem Sleeve Replacement:

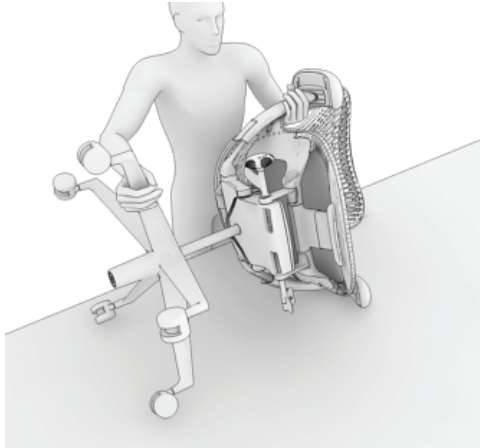

1. Lay the chair on its side.

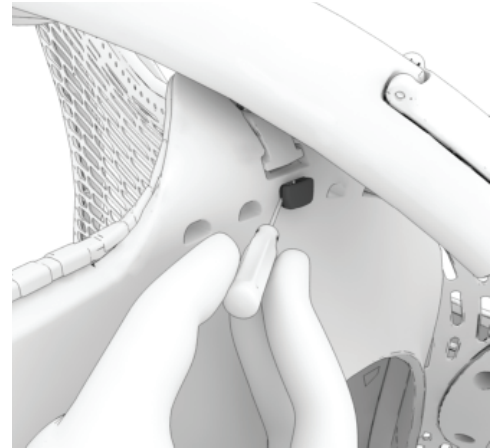

2. Remove the D-Plug from the retainer hole using the small screw driver. Repeat for the opposite side.

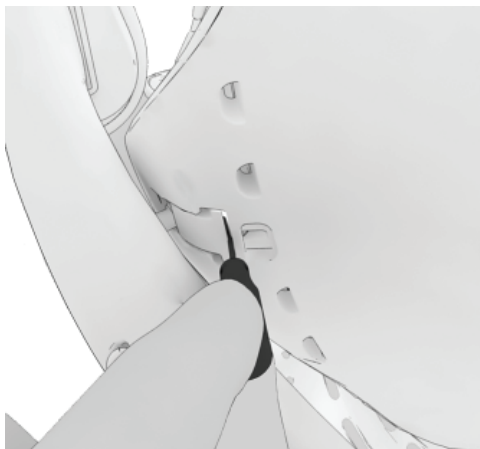

3. Slide the flat head screw driver into slot and depress the spring clip.

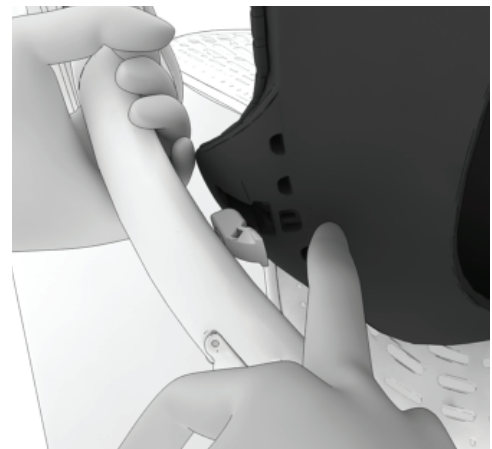

4. Lift up on the seat while depressing the spring clip. Repeat for the opposite side.



5. Stand the chair upright and roll the seat forward.

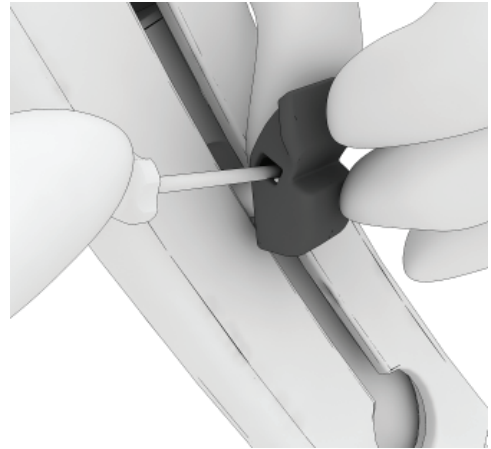

6. Rotate the Hip Pivot Bushing upside down. Insert the flat head screw driver into the hole and release the tab by depressing the clip.

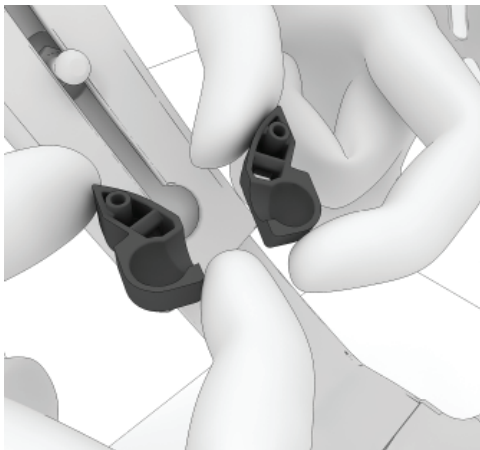

7. Hip Pivot Bushing removed.

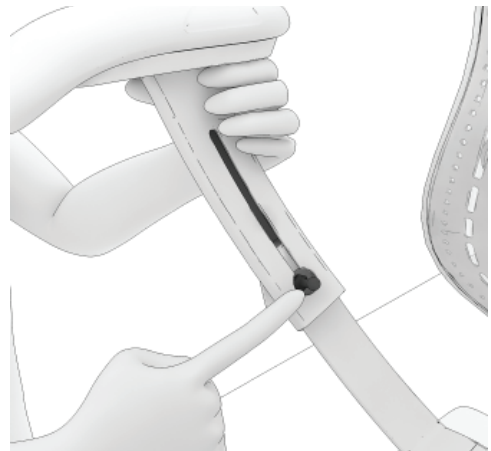

8. Align the hole in the arm with the arm support post.

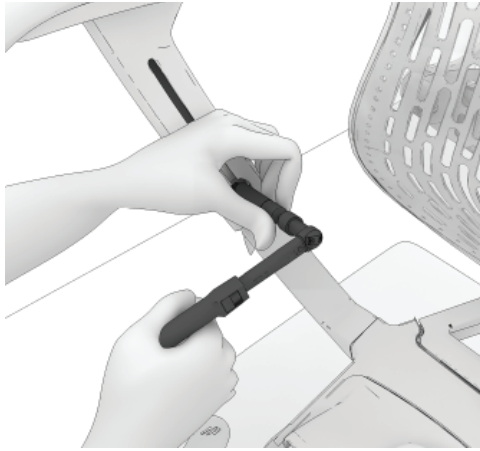

9. Using 13mm deep socket remove the Arm Support Post.



10. Arm Support Post removed.



11. Remove the washer from arm. New Arm Support Post does not use washer.

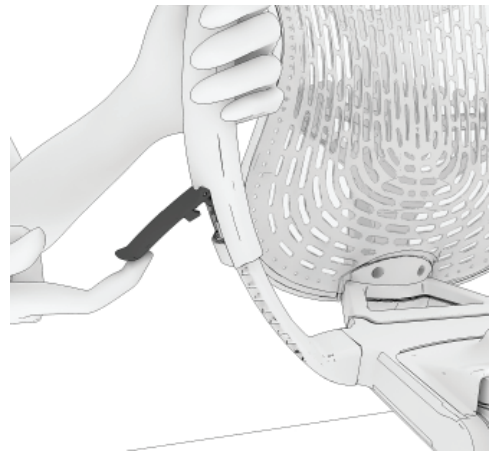

12. Release the catch on the arm.

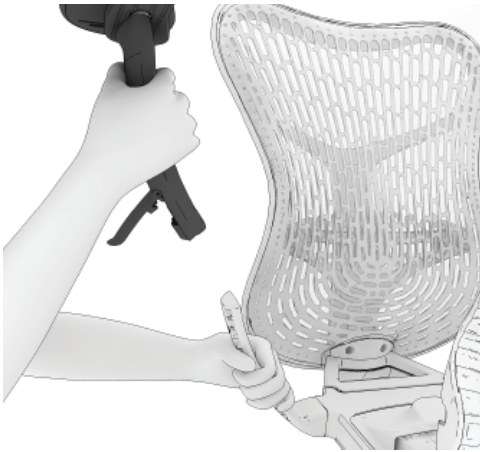

13. Slide the entire assembly up to remove the arm.

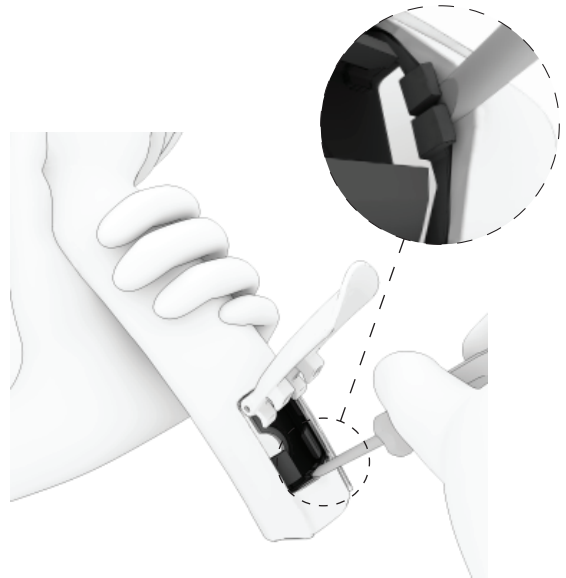

14. Using a flat head screw driver push the plastic tabs on bearing downwards to disengage the tabs from arm sleeve.



15. Slide the Plastic Sleeve Bearing out of the arm.

Re-Assembly Steps:



16. Align the two halves of the Plastic Sleeve Bearing as shown. Make sure the tab engages with the notch on the other side.

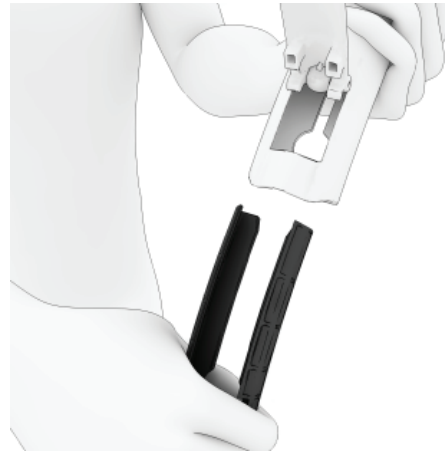

17. Slide the new bearing assembly into the arm.

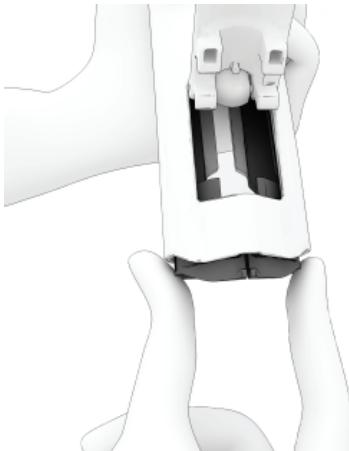

18. Push inside until the plastic bearing tab snaps into position.

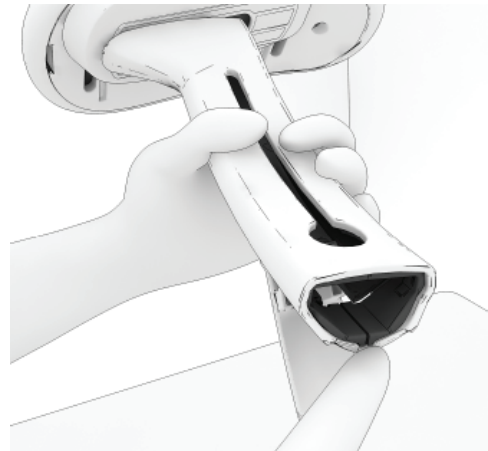

19. While installing arm assembly make sure the plastic bearing is seated inside the arm. It may be extended out.

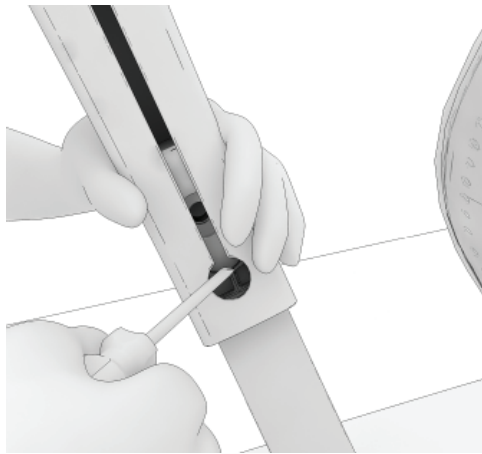

20. Using flat head screw driver slide the sleeve back down if it is not properly seated.

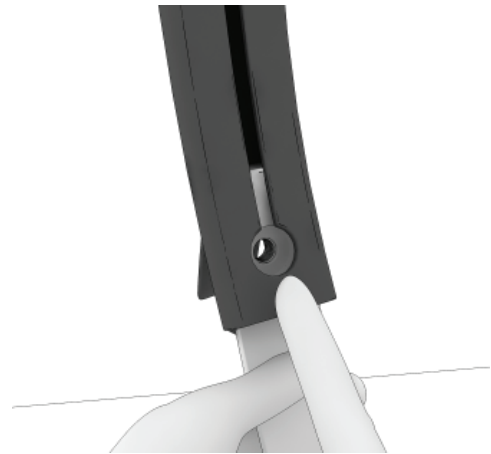

21. Align the opening in the arm up with the hole in the arm support casting.



22. Install the washer into arm. New Arm Support Post does not use washer.



23. Hand start the Arm Support Post.

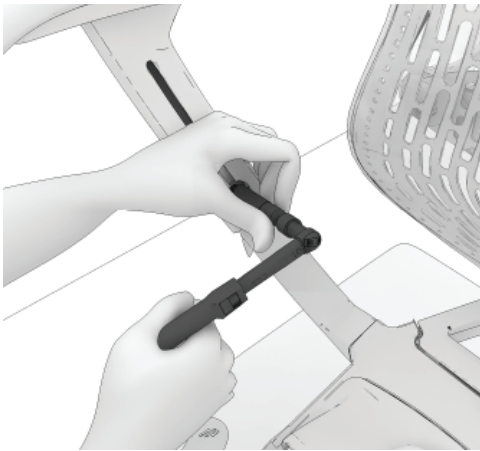

24. Using a 13mm deep socket tighten the Arm Support Post. Torque to 300 in/lbs.

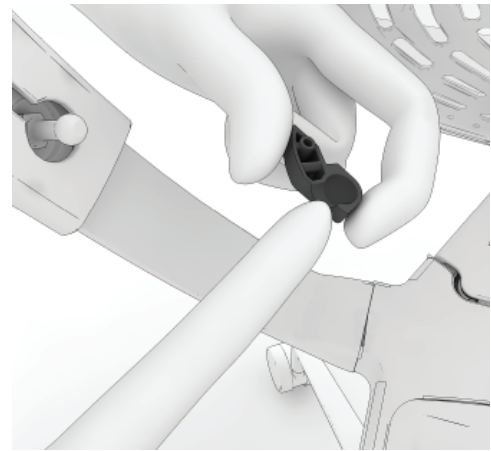

25. Install the new Hip Pivot Bushing on the ball end of the Arm Support Post. Note: The bushing will only go on one way.

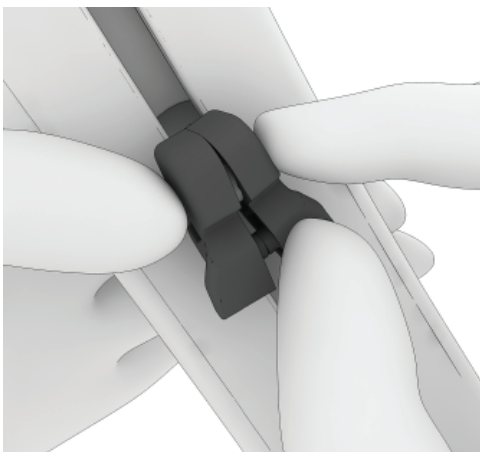

26. Snap the two halves of the Hip Pivot Bushing together.

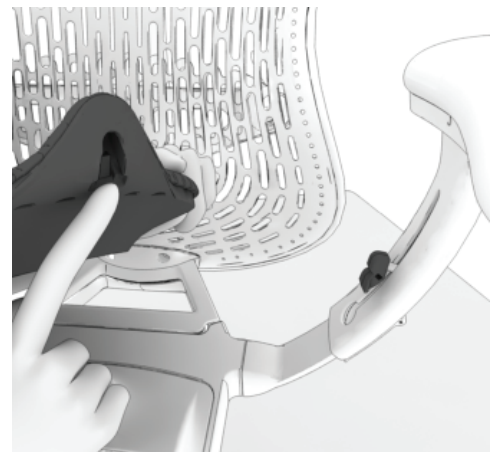

27. Rotate the seat to the in use position sliding the Pivot Bushing into the keyed opening in the seat.

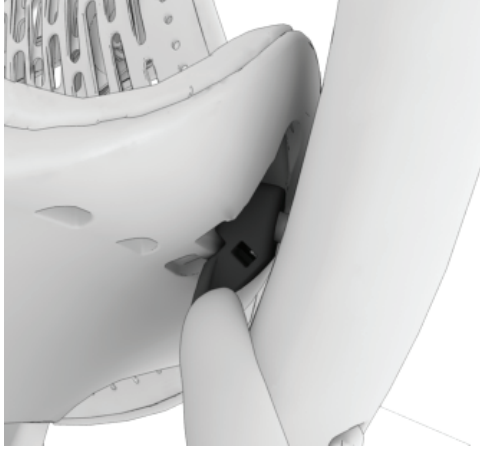

28. Push down until it snaps.

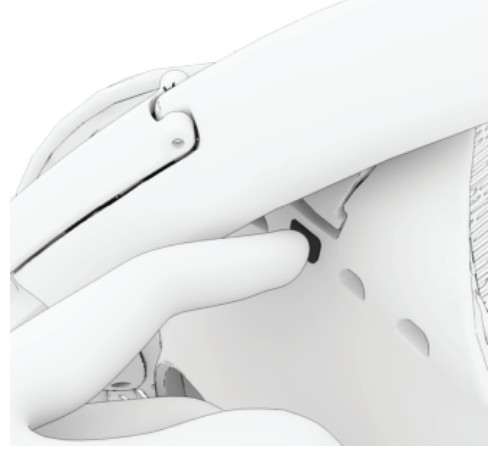

29. Reinstall D-Clips.

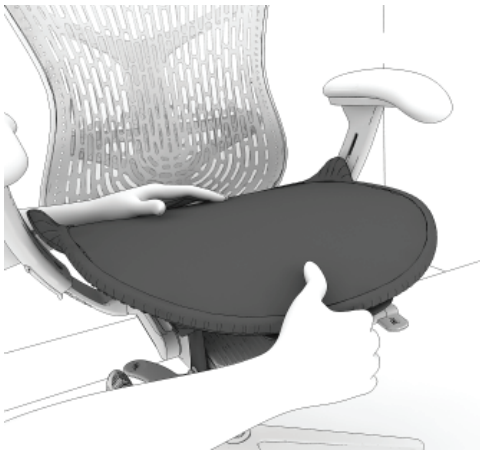

30. Check for proper function.



Parts Included:



Arm Stem Assembly

Additional notes:

New Style Arm Support Post Implemented 9/2016



Old Style



New Style

Tools Required:



Small Flat Head
Screw Driver



Phillips Head
Screw Driver

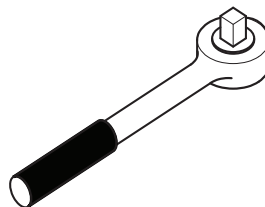

Ratchet Wrench



13mm deep Socket

Steps:

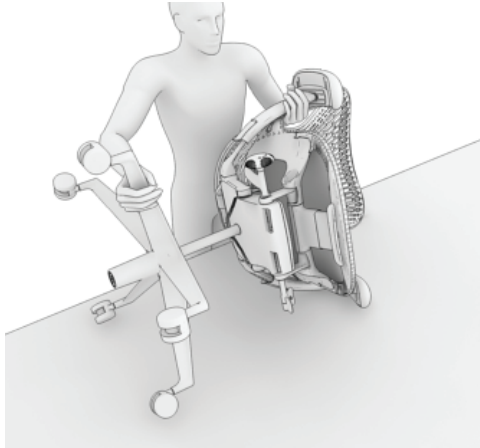

1. Lay the chair on its side.

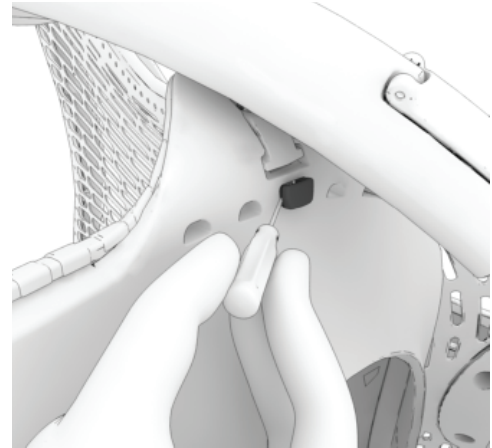

2. Remove the D-Plug from the retainer hole using the small screw driver. Repeat for the opposite side.

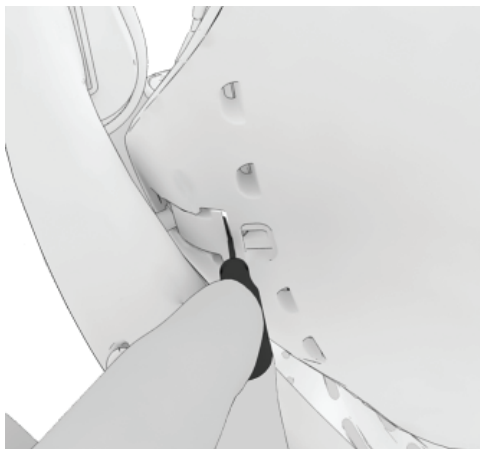

3. Slide the flat head screw driver into slot and depress the spring clip.

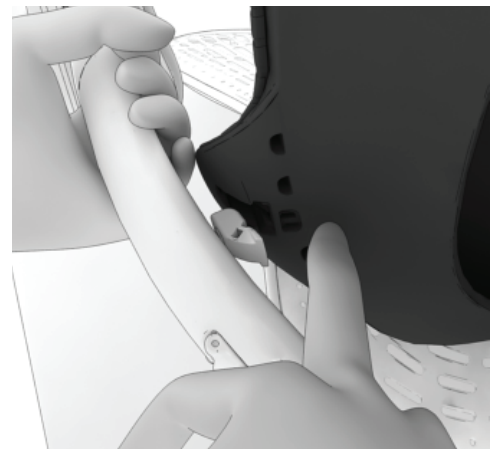

4. Lift up on the seat while depressing the spring clip. Repeat for the opposite side.



5. Stand the chair upright and roll the seat forward.

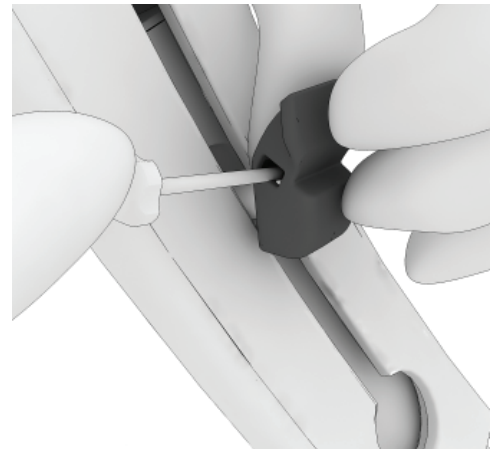

6. Rotate the hip pivot bushing upside down. Insert the flat head screw driver into the hole and release the tab by depressing the clip.

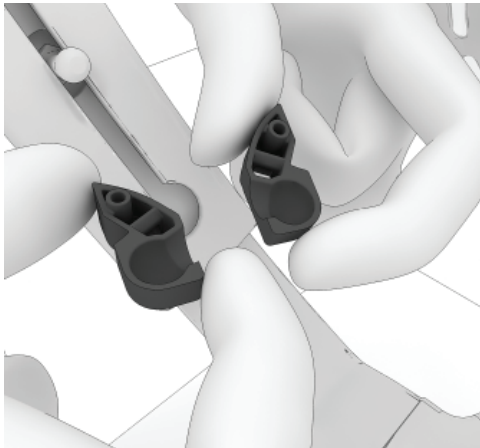

7. Hip Pivot Bushing removed.



8. Align the hole in the arm with the arm support post.

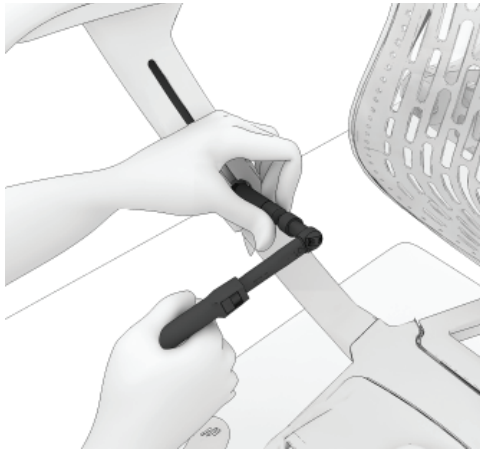

9. Using 13mm deep socket remove the arm support post.



10. Arm Support Post removed.



11. Remove the washer from the arm. New Arm Support Post does not use washer.

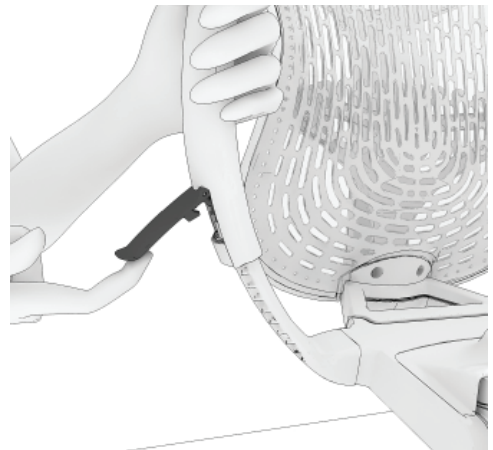

12. Release the catch on the arm.

4D Arm Pad Support Plate Removal

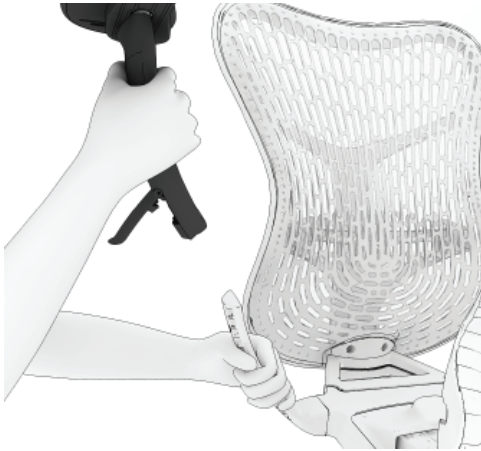

13. Slide the entire assembly up to remove the arm.

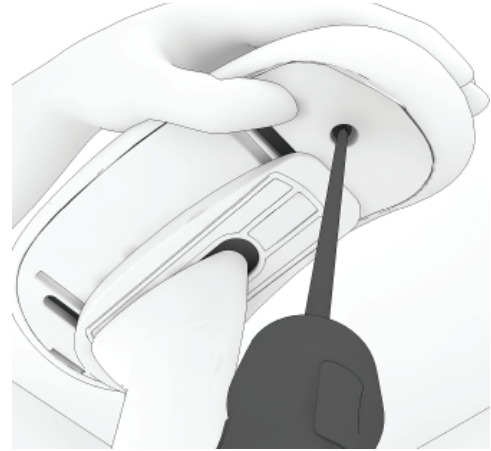

14. Using a T20 torx bit remove the front arm pad bolt.



15. Lift up the arm pad and slide it off.

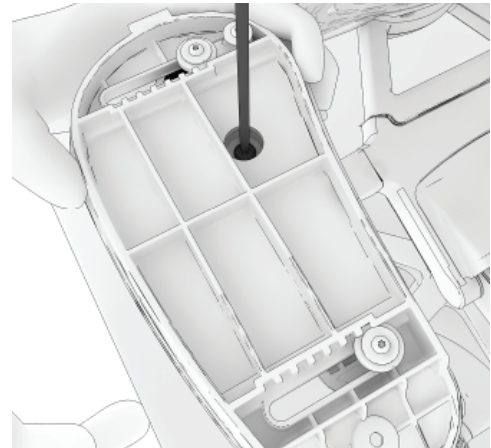

16. Using a T20 torx bit remove the single screw in the center.

Note: slide the arm pad support plate to gain access to the screw.

1D & Fixed Arm Pad Support Plate Removal

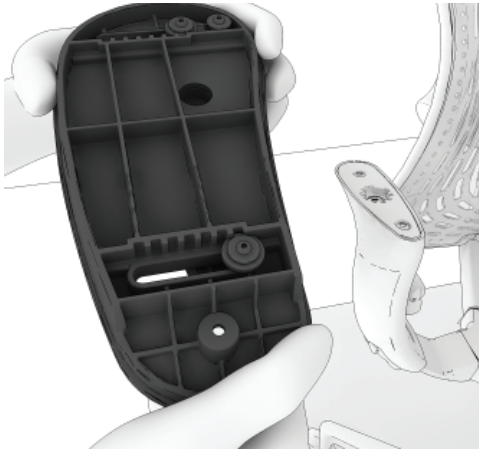

17. Arm pad removed.

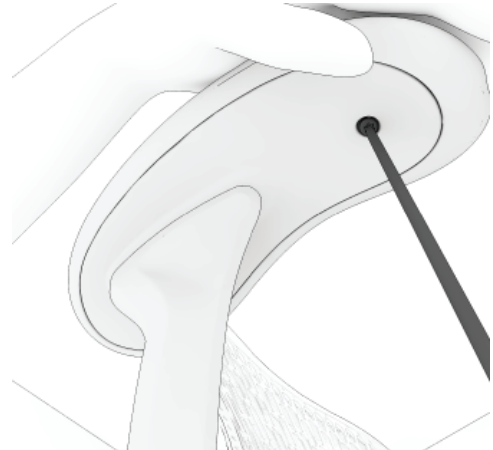

18. Using philips T20 torx bit remove the front arm pad bolt.

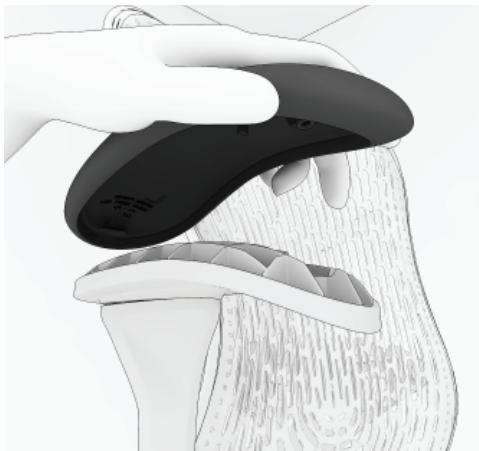

19. Lift up the arm pad and slide it off.

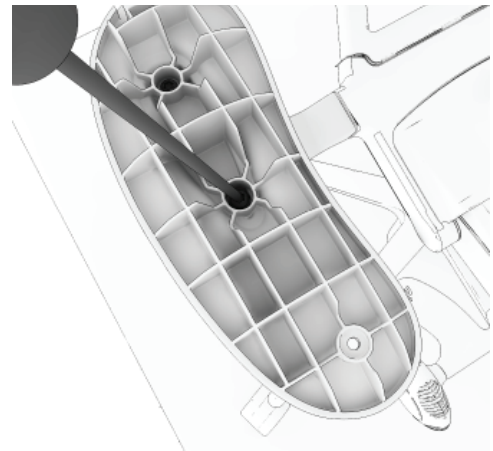

20. Using a T20 torx bit remove the two screws from the arm pad support plate.

Note: slide the arm pad support plate to gain access to the screw.

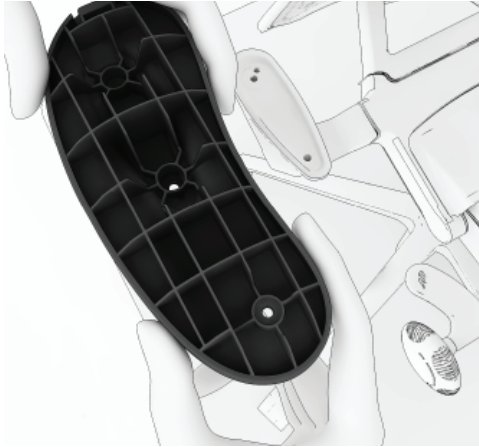

21. Arm Pad Support Plate removed.

Re-Assembly Steps:

4D Arm Pad Support Plate Installation



22. Position the arm plate on the arm stem.

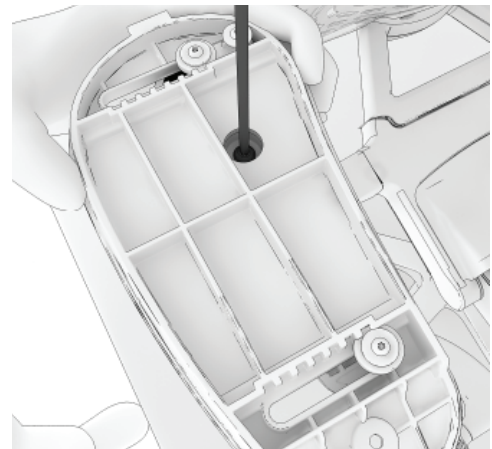

23. Reinstall the attachment bolt and tighten it to 60 in/lbs.

HermanMiller

Part no. 1BBT3K rev D.

© 2016 Herman Miller, Inc. Zeeland, Michigan. Printed in the U.S.A.
©  Herman Miller, Mirra 2 are among the registered trademarks of Herman Miller, Inc.

Illustrations and specifications are based on the latest product information available at the time of publication. The right is reserved to make changes in design and specifications at any time, without notice, and also to discontinue products.

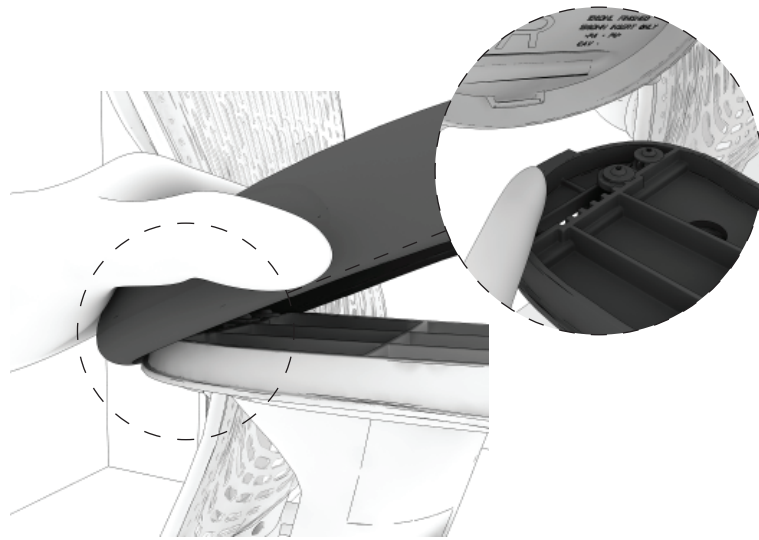

24. Hook the slot on the back of the arm pad over the tab on the arm plate and rotate the arm pad down.

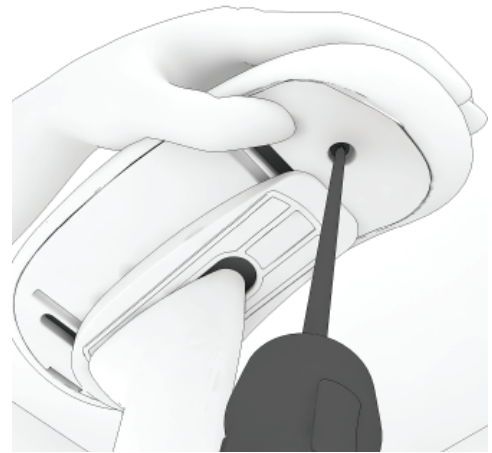

25. Torque to 15 in/lbs.

1D & Fixed Arm Pad Support Plate Installation

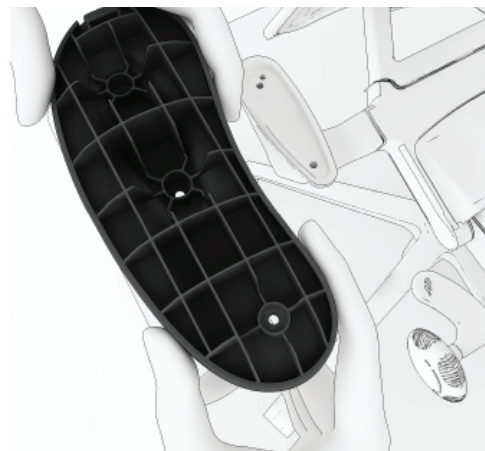

26. Position the arm plate.

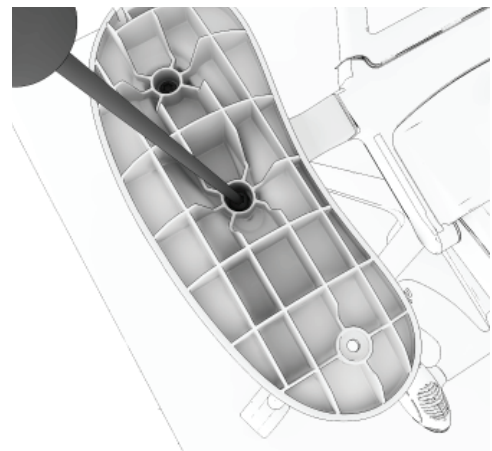

27. Reinstall the two screws and tighten it to 60 in/lbs.

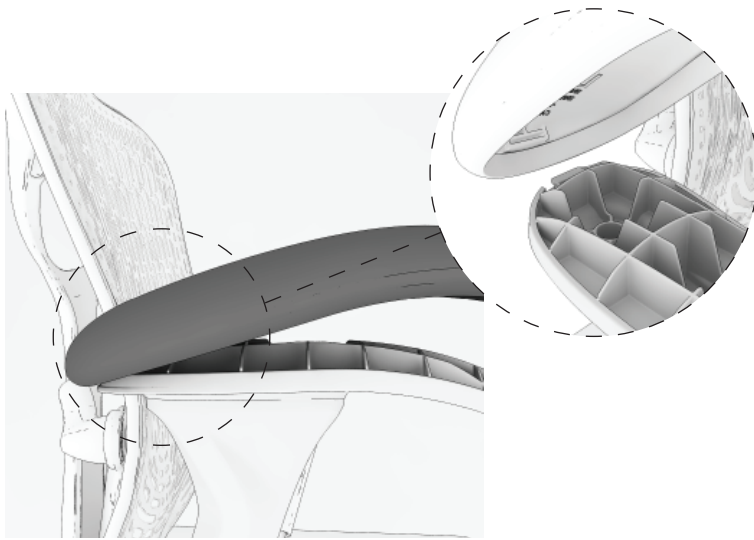

28. Hook the slot on the back of the arm pad into the tab on the arm plate and rotate the arm pad down.

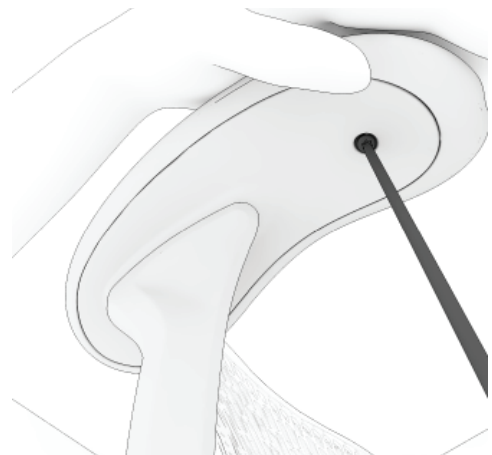

29. Torque to 15 in/lbs.

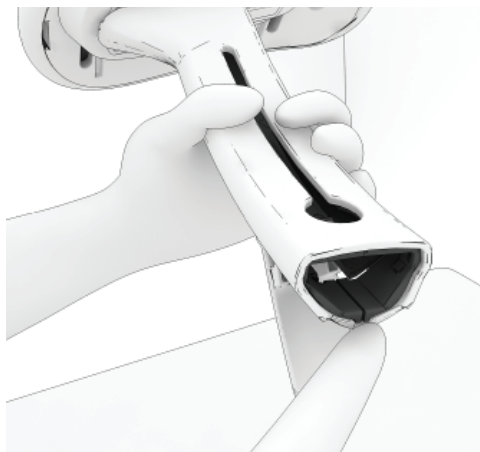

30. While installing new arm assembly make sure the plastic bearing is seated inside the arm. It may be extended out.

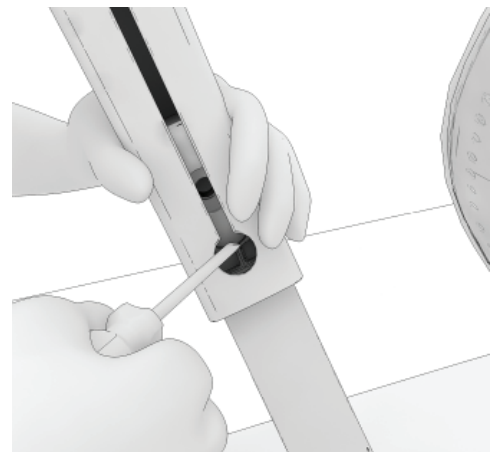

31. Using flat head screw driver slide the sleeve back down if it is not in properly seated.

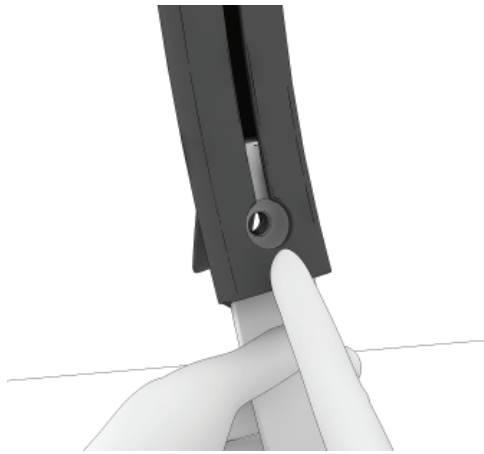

32. Align the opening in the arm up with the hole in the arm support casting.



33. Install the washer into arm. New Arm Support Post does not use washer.



34. Hand start the Arm Support Post.

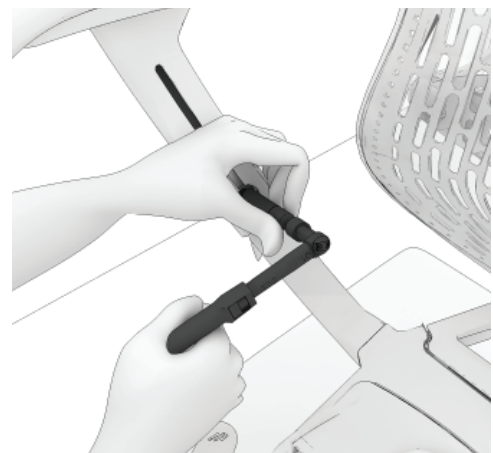

35. Using a 13mm deep socket tighten the Arm Support Post. Torque to 300 in/lbs.

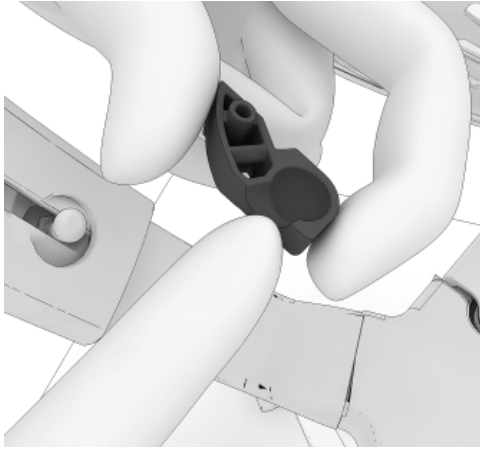

36. Install the new Hip Pivot Bushing on the ball end of the Arm Support Post.
Note: The bushing will only go on one way.

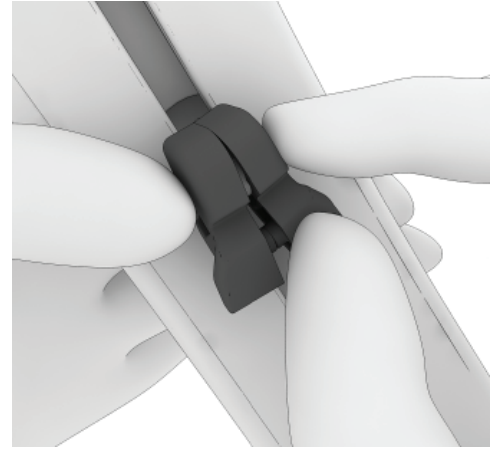

37. Snap the two halves of the Hip Pivot Bushing together.

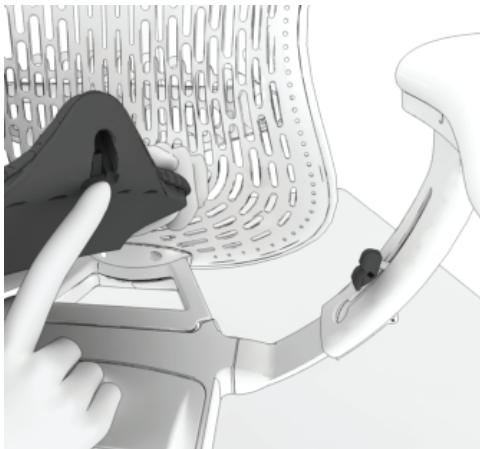

38. Rotate the seat to the end use position sliding the Pivot Bushing into the keyed opening in the seat.

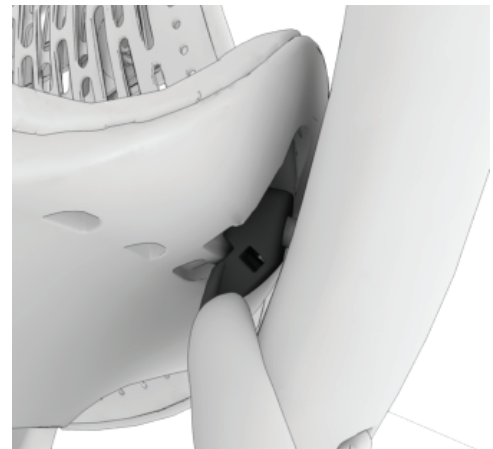

39. Slide it down until a snap.

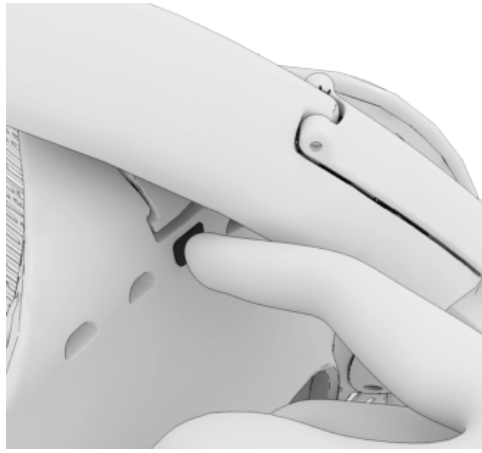

40. Reinstall D-Clips.

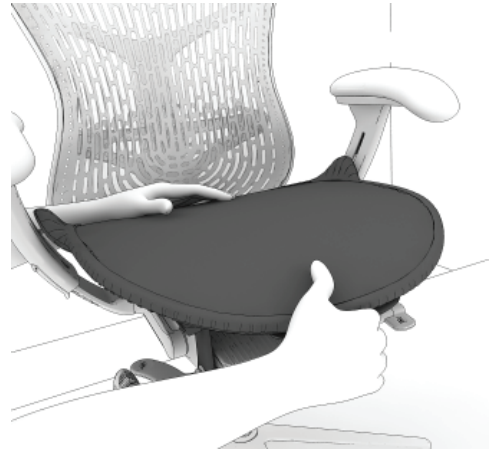

41. Check for proper function.



Parts Included:



Front Link Assembly

Tools Required:



Small Flat Head
Screw Driver

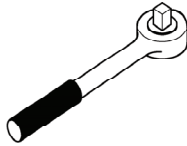

Ratchet Wrench



T40 Torx Bit



T25 Torx Bit

Steps:

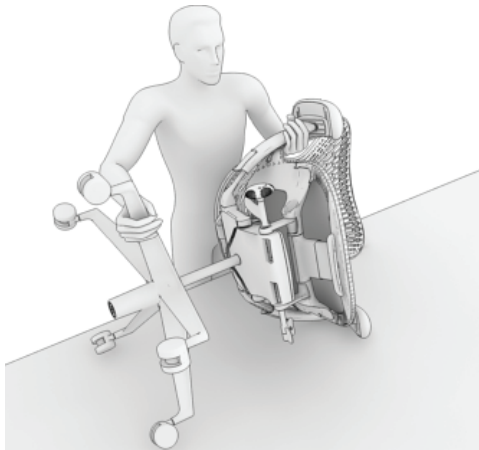

1. Lay chair on its side.

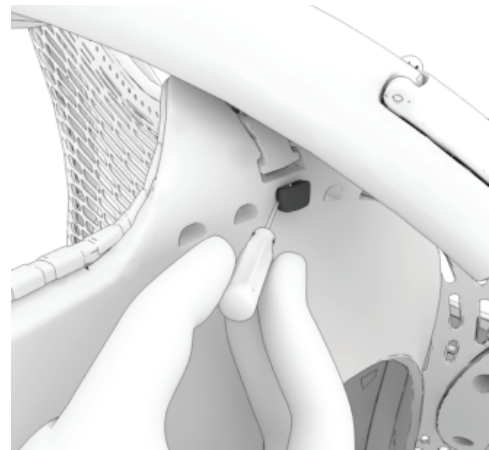

2. Remove the D-Plug from the retainer hole using the small screw driver. Repeat for the opposite side.

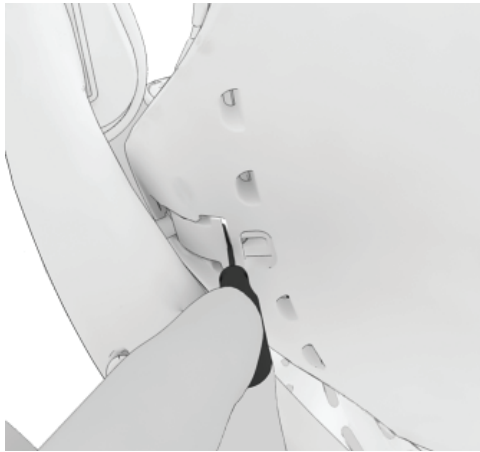

3. Slide the flat head screw driver into the slot and depress the spring clip.

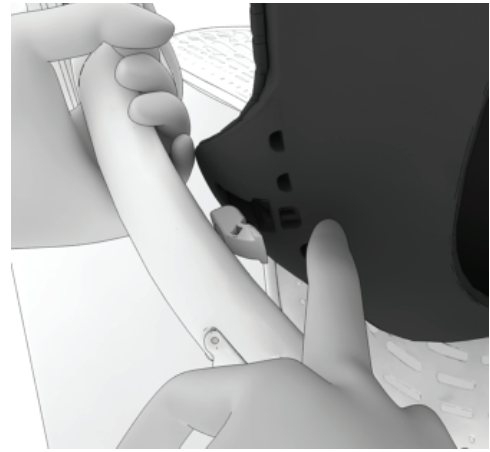

4. Lift up the seat while depressing the spring clip. Repeat for the opposite side.

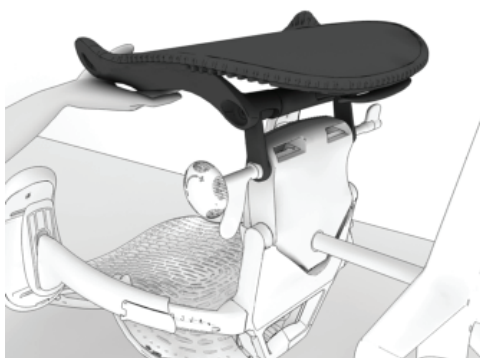

5. Rotate seat assembly forward.

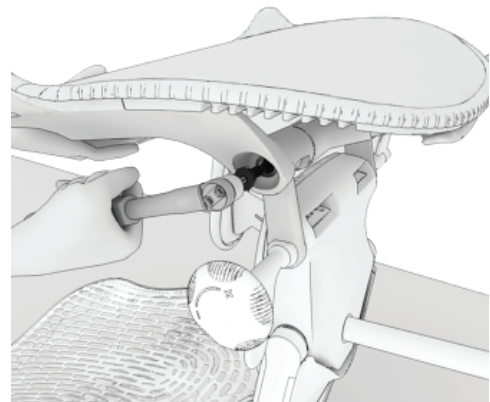

6. Using T40 torx bit remove the retainer bolt. Repeat for the other side.

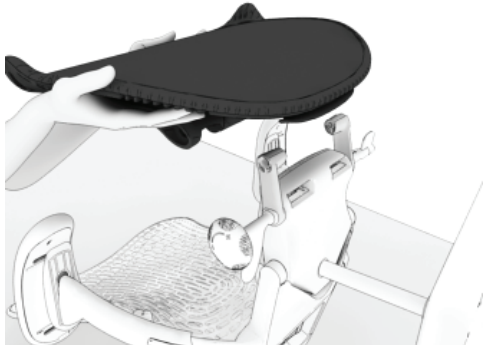

7. Remove the seat from chair.

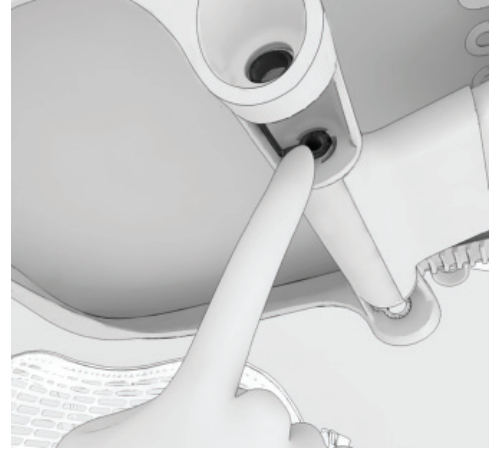

Note: Be careful, not to damage the bushings.

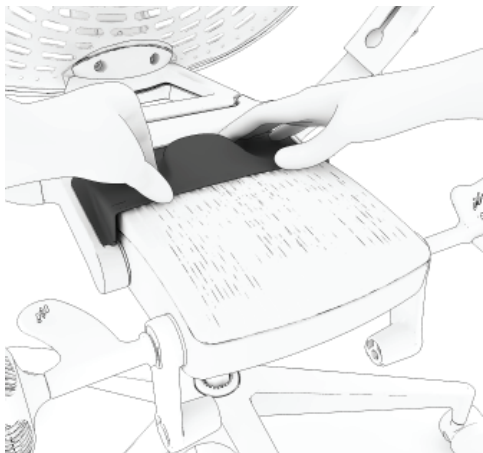

8. Using fingers lift and remove the top rear tilt cover.

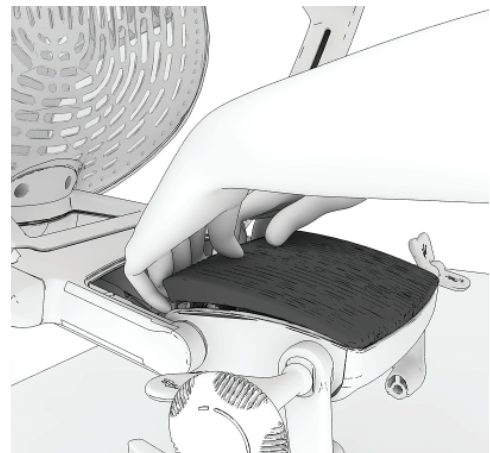

9. Using fingers remove the front tilt cover.

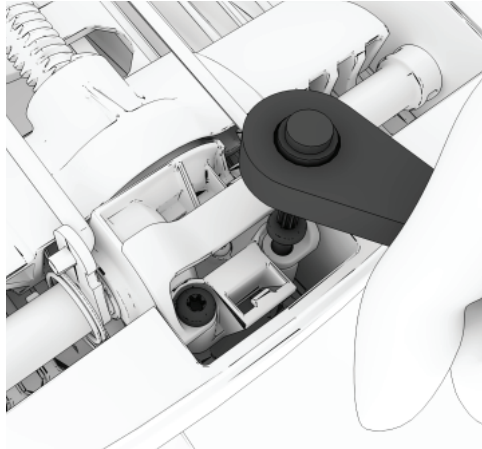

10. Using T25 Torx Bit remove the two screws from the control retainer.

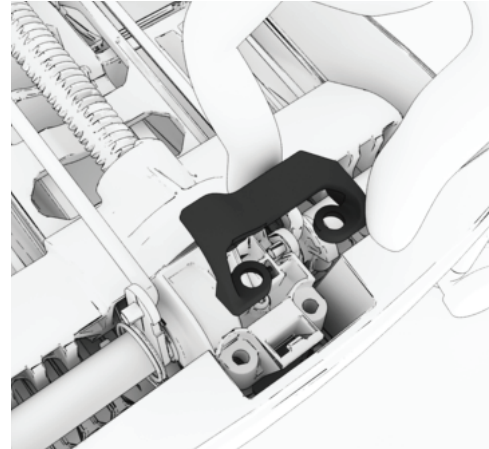

11. The control retainer is removed from the tilt assembly.

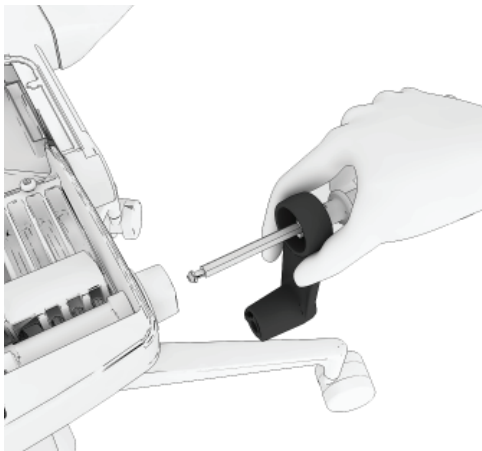

12. Pull the tilt limit control with front link and remove it from the tilt assembly.



13. Remove front link from tilt limit control.

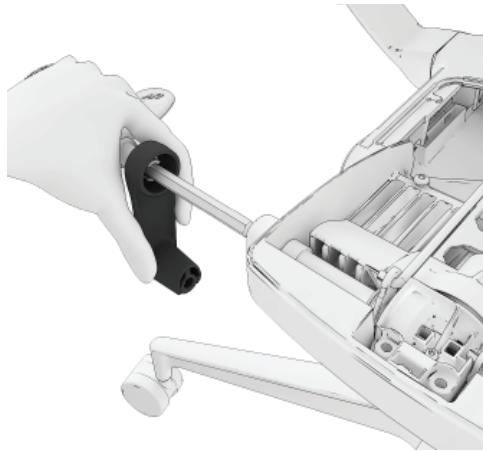

14. Pull the tilt tension control knob and remove it from the tilt assembly.



15. Remove the front link from tilt tension control.

Re-Assembly Steps:



16. Insert new front link into tilt tension height control adjustment knob assembly.

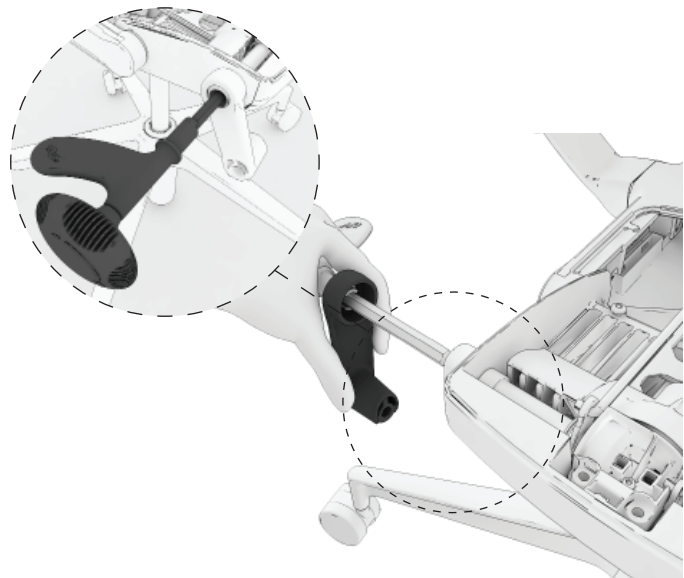

17. Install the tilt tension control knob assembly with front link into tilt assembly.

Note: Height adjustment lever is keyed mate lever key with tilt.



18. Insert new front link into tilt limit control assembly.

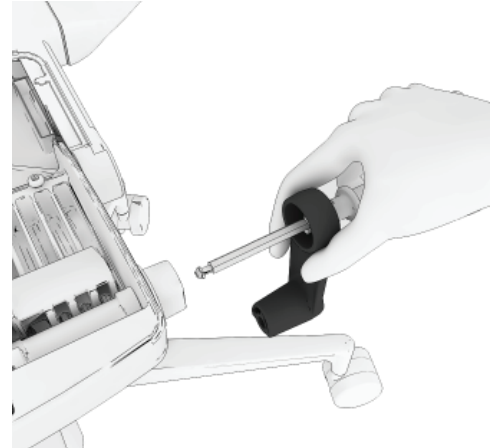

19. Install the tilt limit control assembly with front link into the tilt assembly.

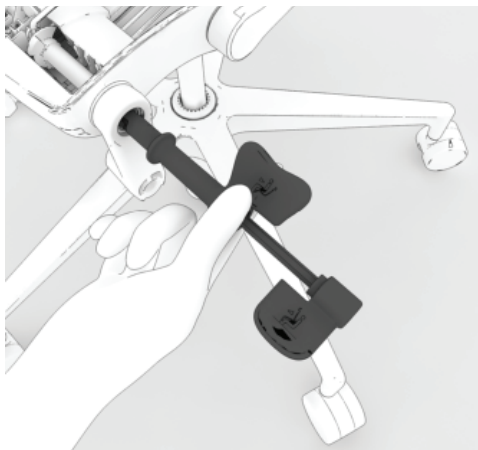

20. Rotate the rear tilt limit control handle until it locks into the keyed mating part in the tilt.

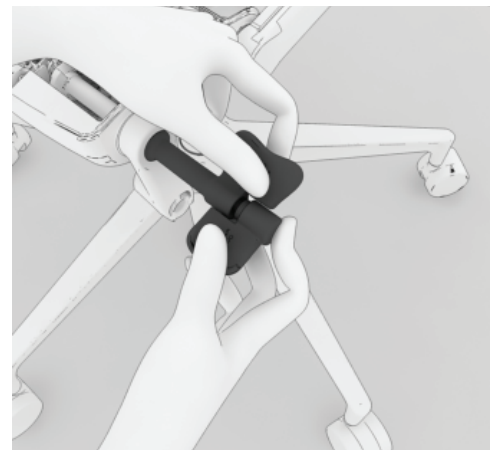

21. Slide the forward angle lever control knob over the rear tilt lever control knob. While applying pressure rotate them together until they snap into the tilt housing.

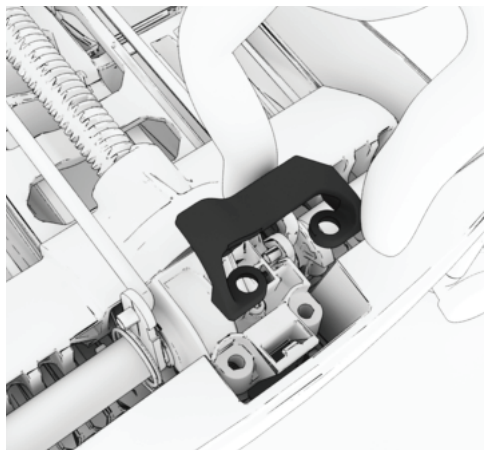

22. Install the control retainer into tilt assembly.

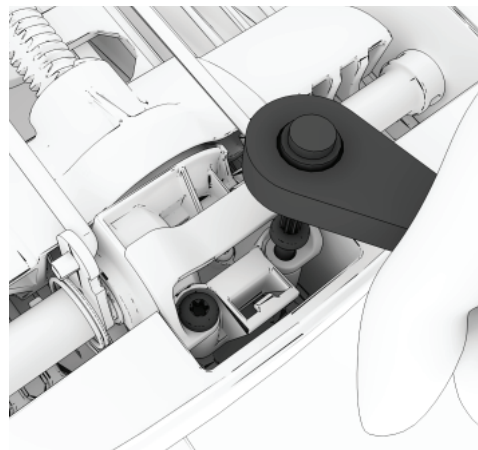

23. Using T25 Torx bit install the two screws. Torque to 60 in/lbs. Check all levers for proper function.

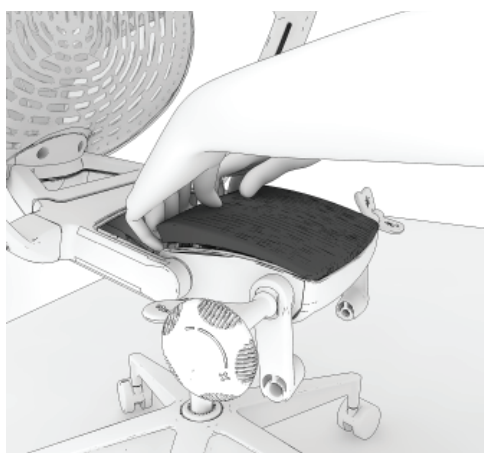

24. Position the top front tilt cover and snap it in place.

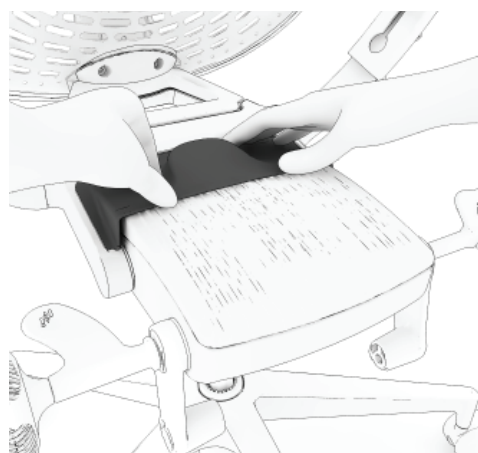

25. Position the top rear tilt cover and snap it in place.

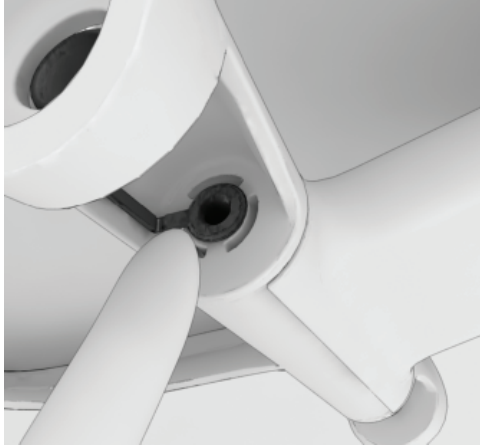

Note: Before re-attaching the seat to the front links make sure the bushings are still in place.

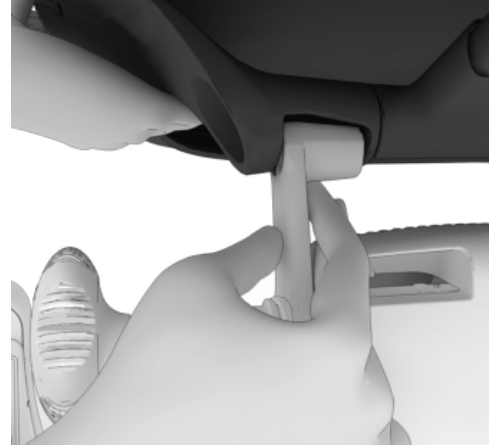

27. Rotate the seat down over the Front Links and align with the slot in the seat.

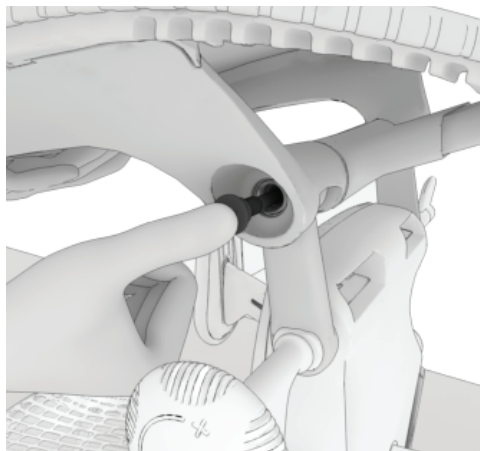

28. Install the bolts on both sides.

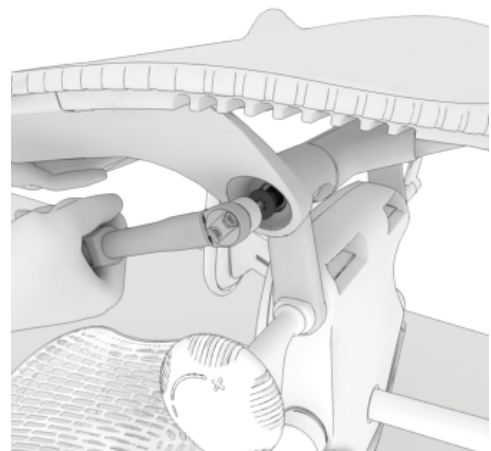

29. Using T40 torx bit, tighten the bolts. Torque to 300 in/lbs.

Caution: Do not over torque.

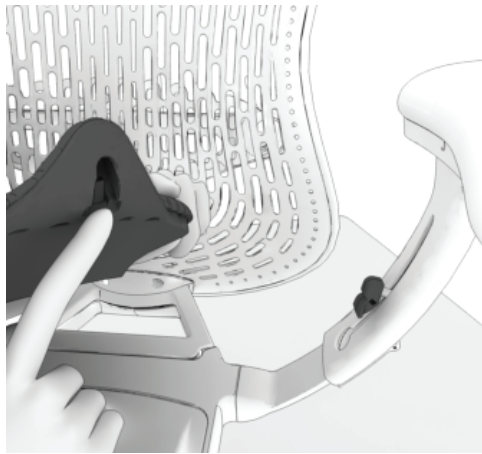

30. Rotate the seat to the end use position sliding the Pivot Bushing into the keyed opening in the seat.

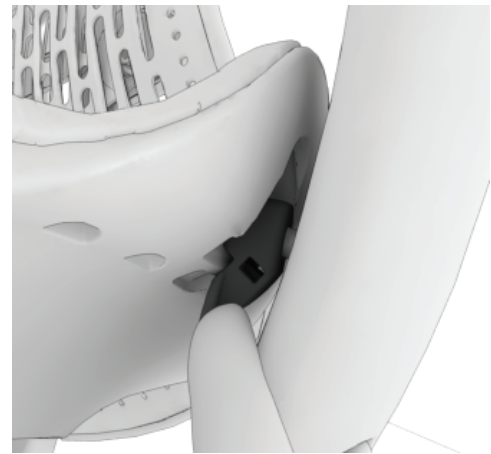

31. Push down until it snaps.

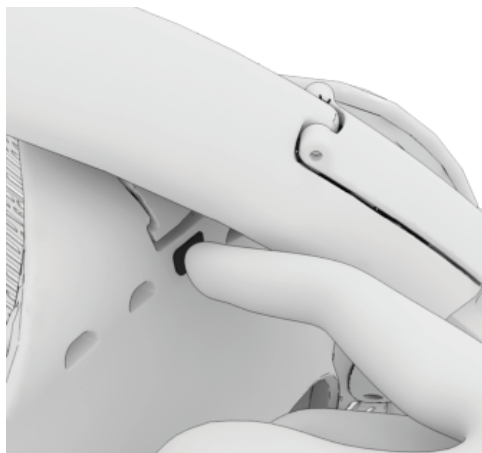

32. Install the D-Clips into seat.

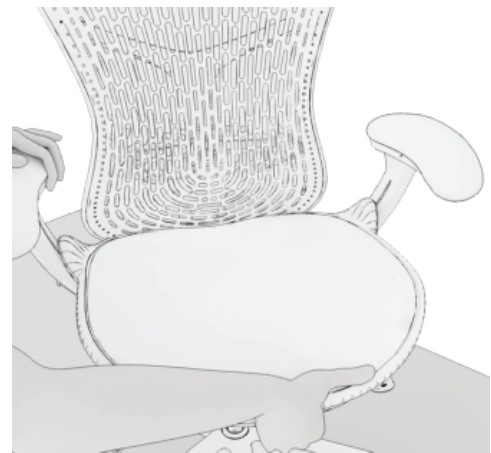

33. Check for proper function.



Tools Required:

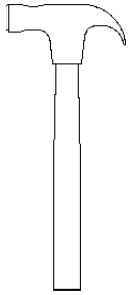

Hammer



Nylon Cap

Steps:

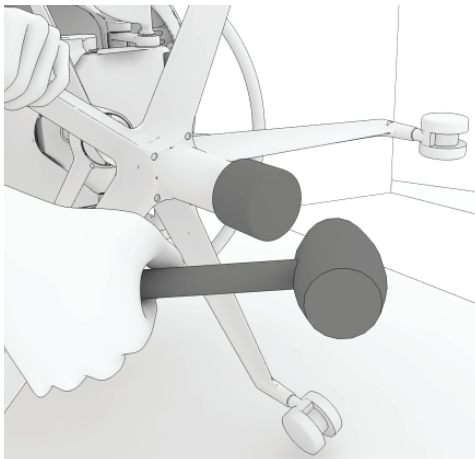

1. Place nylon cap over the end of cylinder and strike with hammer.



2. Disengage the base from cylinder.



3. Take out the footring from cylinder.

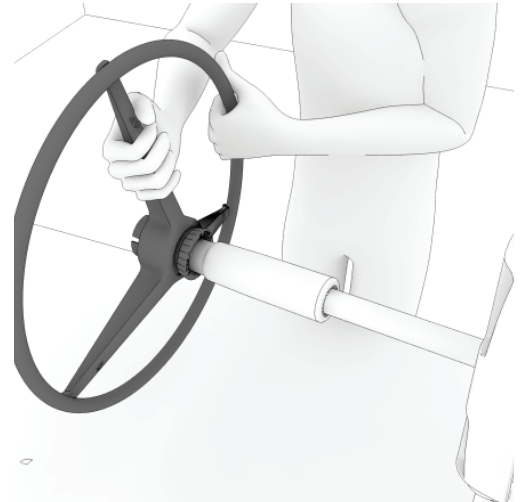

4. Place the footring into cylinder.

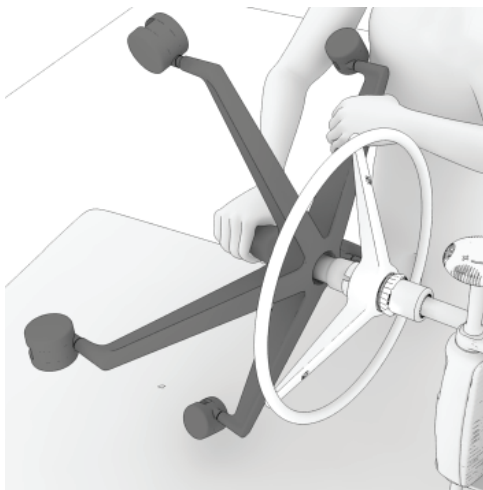

5. Place the base into cylinder.



4. Sit on chair firmly several times to set cylinder and base.

HermanMiller

Part no. 1BFM0V rev B.

© 2014 Herman Miller, Inc. Zeeland, Michigan. Printed in the U.S.A.
™ and Compass are among the trademarks of Herman Miller, Inc.

Illustrations and specifications are based on the latest product information available at the time of publication.
The right is reserved to make changes in design and specifications at any time, without notice, and also to discontinue products.