

HermanMiller

The Collection

Nelson™ Bench Installation



How to assemble your bench.

For more information about our products and services or to see a list of dealers, please visit us at hermanmiller.com or call (800) 851 1196.

© 2013 Herman Miller, Inc., Zeeland, Michigan Printed in U.S.A. Part No. 1b9l4t - C.

TM Nelson are among the trademarks of Herman Miller, Inc.

Tools required



#2 Phillips Screwdriver

Parts Included

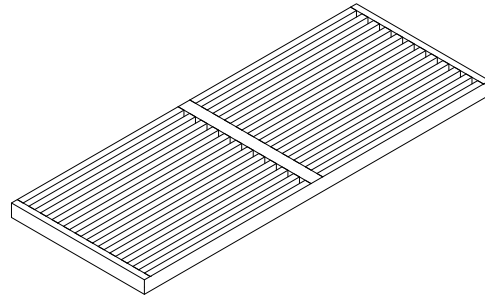

A Bench Assembly

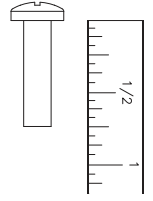

B 3/4" Long pan head machine screw (2)



Warning:

Failure to fully tighten screws may cause injury by causing bench to collapse. Tighten screws until they stop plus a quarter turn.

Step 1

1.1 Lay bench assembly (A) top side down on a clean surface.

1.2 Pivot leg assemblies up.

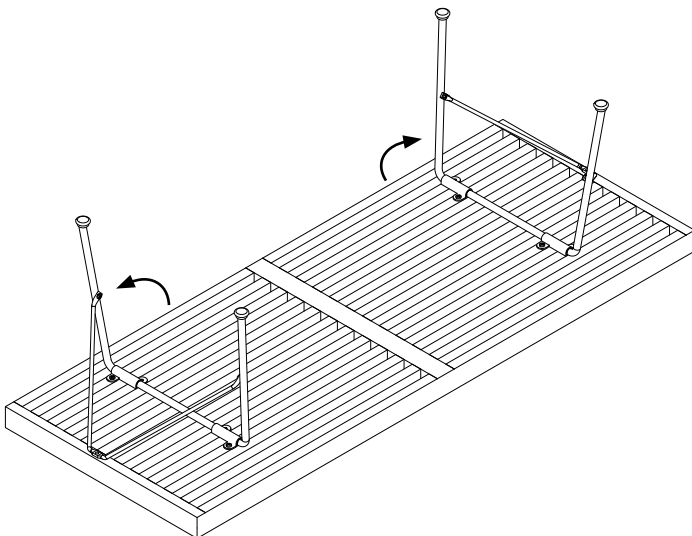

Step 2

2.1 Align holes in V brackets with metal insert in bench slats.

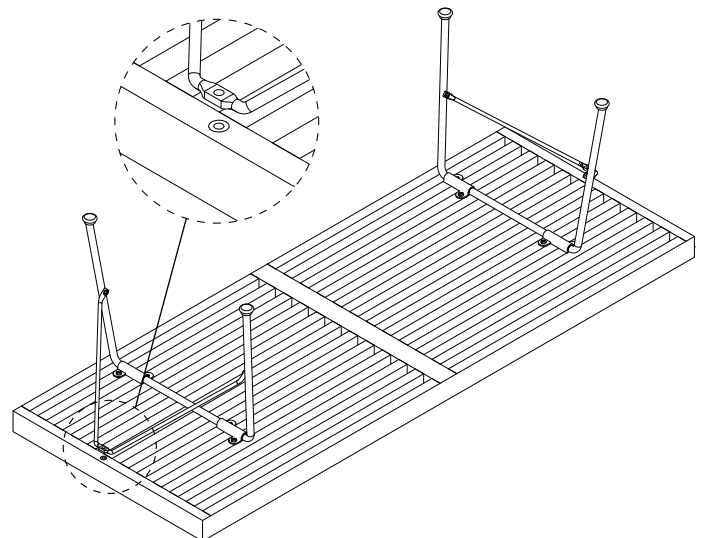

Step 3

3.1

Insert machine screws (B) into each leg assembly. Tighten screws.

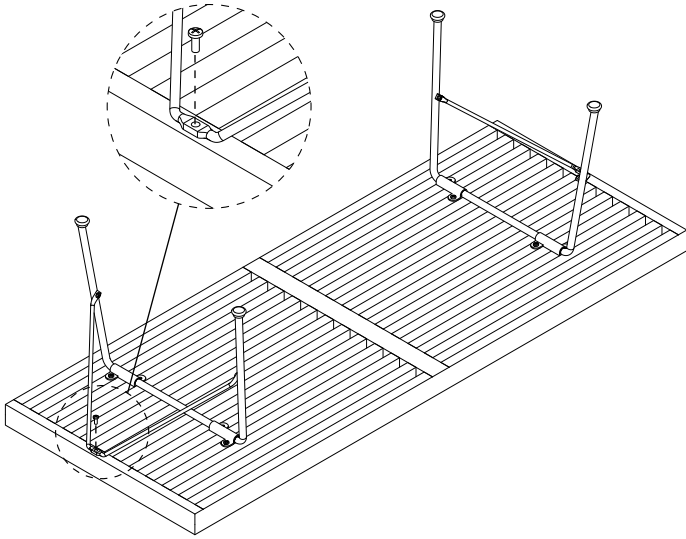

Step 4

4.1

Place table in upright position.

