



---

# Table of Content

1. Post Leg Installation ('P' option).....	2
2. T & C - Leg Installation (T & C options).....	4
3. T & C - Adjustable Leg Installation (A + D option).....	7
4. Flip Top Leg & Assembly Installation (DT5A Product).....	10
5. 4X Leg Installation (X - option).....	14
6. Single Column Leg Installation (S option).....	17
7. Y3 Leg Installation (E option).....	21
8. Y2 Leg Installation (G option).....	24
9. Byrne Interlink.....	27
10. Extended Meeting Table.....	28



# Everywhere Tables™ Post Leg Installation (P) and Disassembly for Recycling Instructions

## Parts Included:

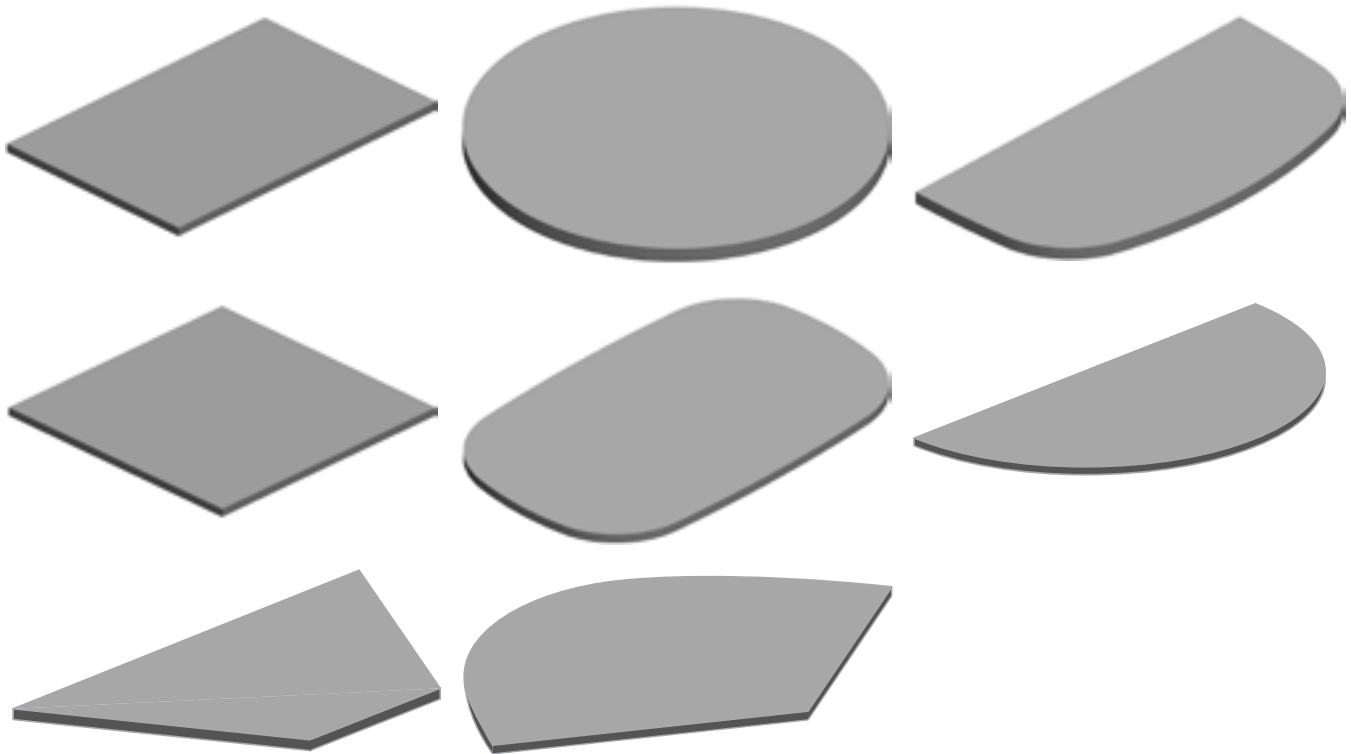

### A Work Surface Options

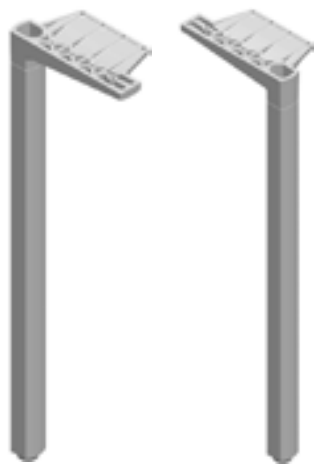

**B** Post Leg Option (2 Sets)

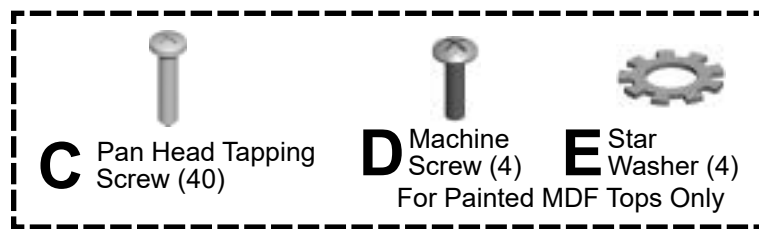

Hardware Pack

## Tools Required:

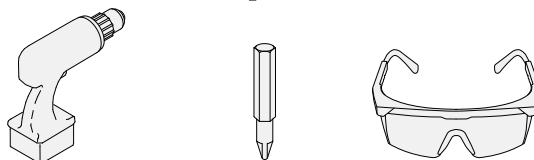

Power Driver #2 Phillips Bit Safety Glasses

## Assembly Instructions:

---

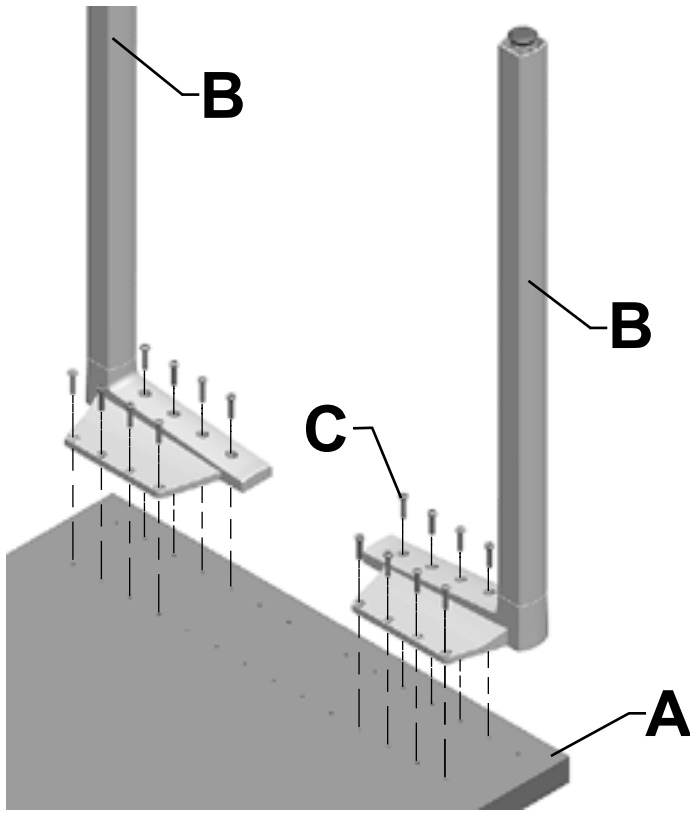

1. Align Holes in Post Legs (B) with outermost holes in Work Surface (A).
2. Install 8 Pan Head Tapping Screws (C) per Leg (HPL + Veneer) or 7 pan head Screws per leg (C) (Painted MDF).
3. For use on 'painted MDF tops' use (D)+(E) in locations where an insert is present in the hole pattern.

## Disassembly for Recycling:

### Materials Identification and Segregation:

Where possible, plastic components are marked with ASTM recycling codes. Use these codes to identify material type for recycling. Non marked components should be treated as mixed plastic. Ferrous metals can be identified using a small magnet for recycling. Non-ferrous metals should be separated and recycled separately.

To disassemble product, reverse steps 3 through 1.



# Everywhere Tables™ T & C Leg Installation (T & C options) and Disassembly for Recycling Instructions

## Parts Included:

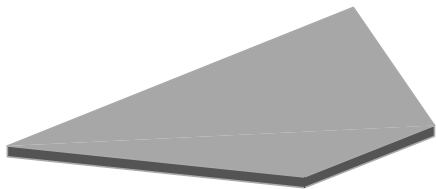
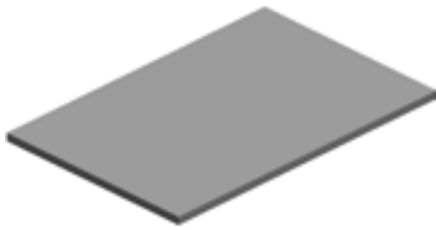

**A** Work Surface Options



**B** T Leg Option (2 Sets)



**C** C Leg Option

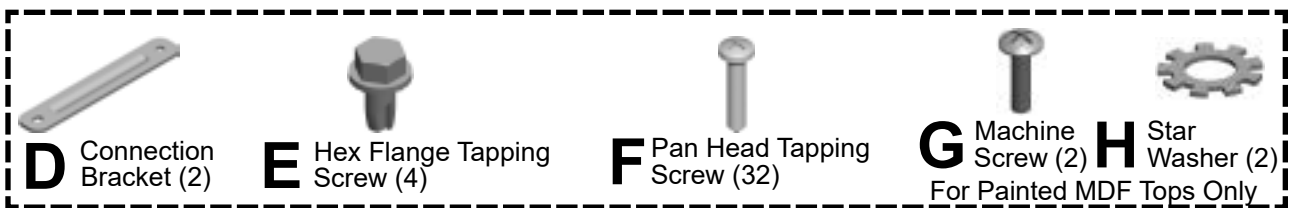

Hardware Pack

## Tools Required:

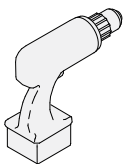

Power Driver

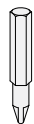

#2 Phillips Bit

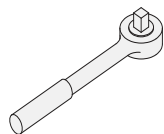

Ratchet Wrench



3/8" Socket

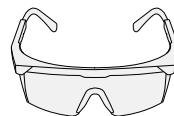

Safety Glasses

**HermanMiller**

Part no. 1b6k0d rev K

© 2023 Herman Miller, Inc. Zeeland, Michigan. Printed in the U.S.A.  
™, © Herman Miller, Everywhere Tables are among the trademarks of Herman Miller, Inc.

Illustrations and specifications are based on the latest product information available at the time of publication. The right is reserved to make changes in design and specifications at any time, without notice, and also to discontinue products.

# Assembly Instructions:

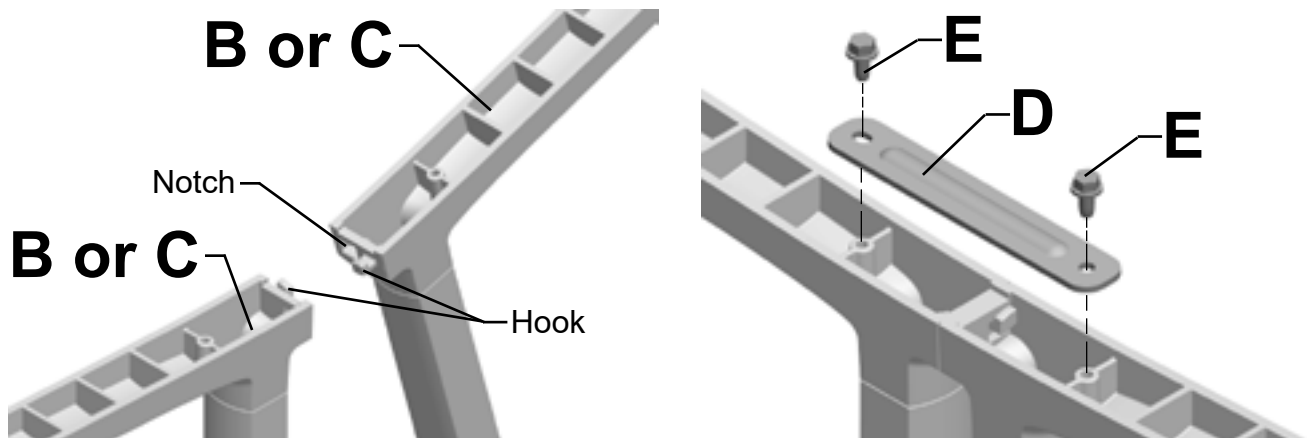

1. Hold Leg segments (B or C) at 15 degree angle to one another.
2. Insert Hooks on base of leg segments into notches in adjoining leg segments.
3. Secure Leg segments together with Connection Bracket (D) and 2 Hex Flange Tapping Screws (E). (Per Leg) Do not overtighten.

“T” Leg

“C” Leg

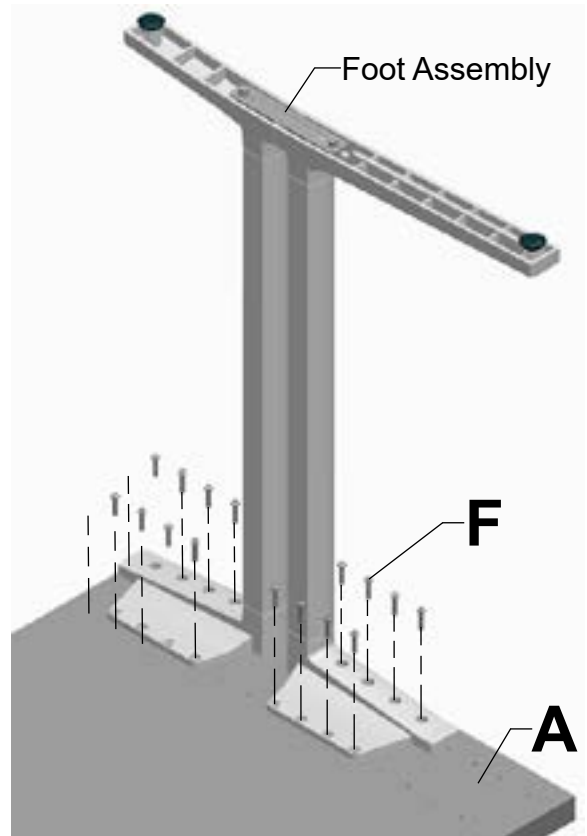
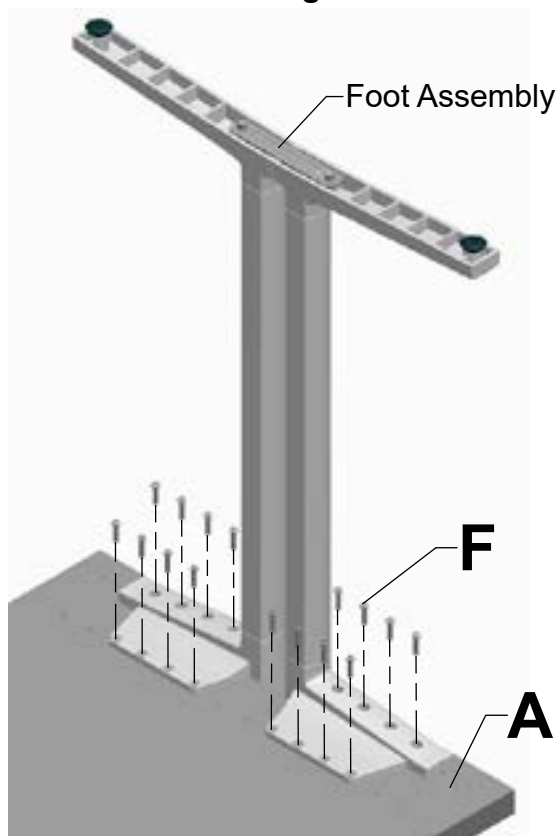

4. Position Leg Assembly at each end on bottom side of Work Surface (A) so that Foot Assembly is centered on depth of Work Surface.
5. Install Pan head tapping screws (F) 16 per Leg Assembly. Exception on painted MDF tops, use machine screw (G) and star washer (H) in locations where insert is present in the hole pattern.

**HermanMiller**

Part no. 1b6k0d rev K

© 2023 Herman Miller, Inc. Zeeland, Michigan. Printed in the U.S.A.  
™  Herman Miller, Everywhere Tables are among the trademarks of Herman Miller, Inc.

Illustrations and specifications are based on the latest product information available at the time of publication.  
The right is reserved to make changes in design and specifications at any time, without notice, and also to discontinue products.

## **Disassembly for Recycling:**

---

### **Materials Identification and Segregation:**

Where possible, plastic components are marked with ASTM recycling codes. Use these codes to identify material type for recycling. Non marked components should be treated as mixed plastic. Ferrous metals can be identified using a small magnet for recycling. Non-ferrous metals should be separated and recycled separately.

To disassemble product, reverse steps 5 through 1.



# Everywhere Tables™ Adjustable Leg Table Installation (A + D options) and Disassembly for Recycling Instructions

## Parts Included:

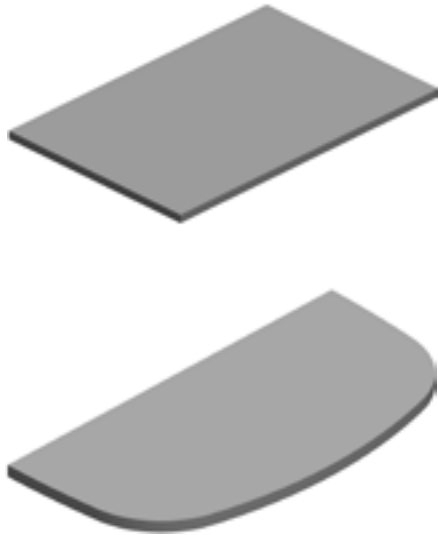

**A** Work Surface Options



**B** T Adjustable Leg Option (2 Sets) (A)



**C** C Adjustable Leg Option (D)

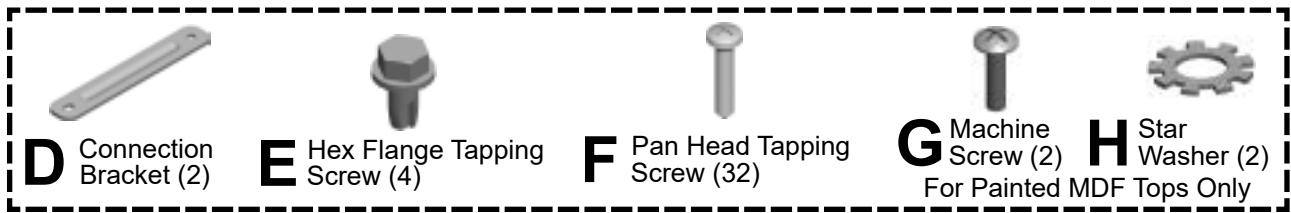

Hardware Pack

## Tools Required:

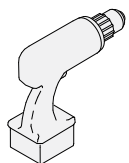

Power Driver



#2 Phillips Bit

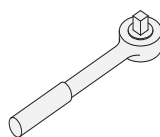

Ratchet Wrench



3/8" Socket



Safety Glasses

# Assembly Instructions:

## Adjustable Leg Installation:

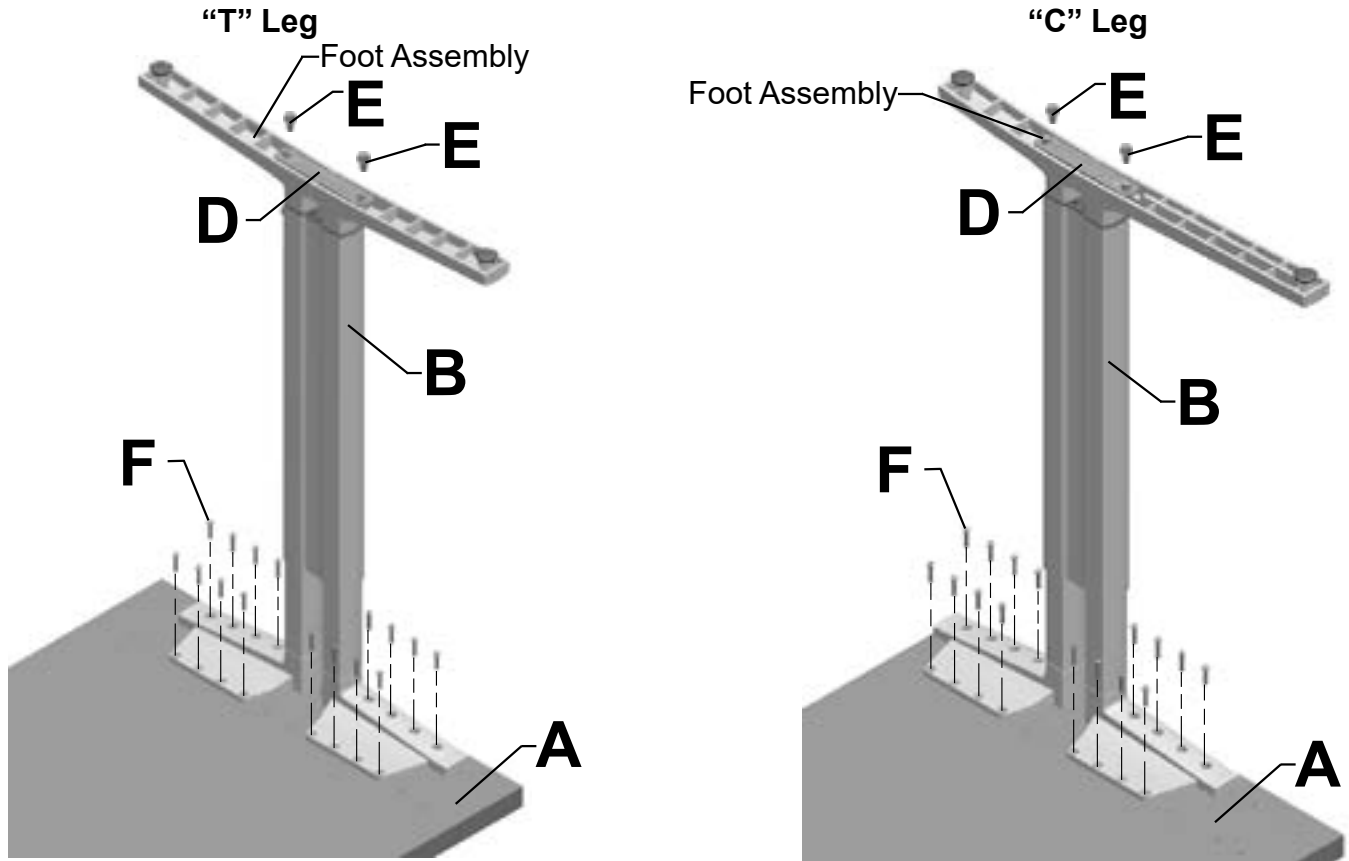

1. Secure leg segments together with connecting bracket (D) and 2 Hex Flange tapping screws (E) (per leg assembly).
2. Position Leg Assembly at each end on bottom side of Work Surface (A) so that Foot Assembly is centered on depth of Work Surface.
3. Install Pan head tapping screws (16) per leg assembly. Exception painted MDF tops. Use machine screw(G) and star washer (H) in locations where insert is present in the hole pattern.

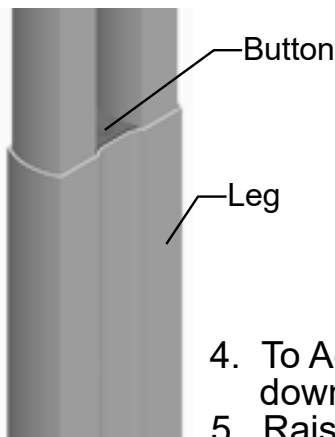

### WARNING:

If the table's pin height adjustment is not properly engaged, the table could unexpectedly drop potentially causing injury. After changing table height, press firmly down on surface to see if table position appears secure.

4. To Adjust work surface height, support work surface then push down on button on Legs.
5. Raise or lower work surface to desired height.



## **Disassembly for Recycling:**

---

### **Materials Identification and Segregation:**

Where possible, plastic components are marked with ASTM recycling codes. Use these codes to identify material type for recycling. Non marked components should be treated as mixed plastic. Ferrous metals can be identified using a small magnet for recycling. Non-ferrous metals should be separated and recycled separately.

To disassemble product, reverse steps 5 through 1.



# Everywhere Tables™ Flip - Top Table Installation and Disassembly for Recycling Instructions

## Parts Included:

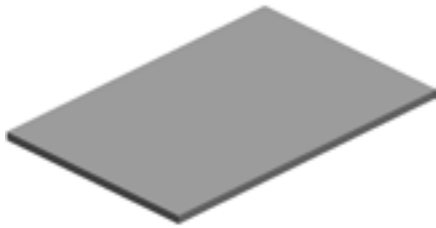

**A** Work Surface Options



**B** Leg Assembly (2)



**C** Cross Member Assembly



**D** Paddle (2) Assembly



**E** Pan Head Tapping 1.5" long screws (8)



**F** Connection Bracket (2)



**G** Hex Flange Tapping Screw (4)



**H** Pan Head Tapping Screw 3/4" long (8)

Hardware Pack

## Tools Required:

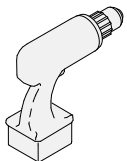

Power Driver



#2 Phillips Bit

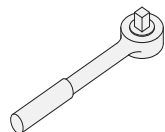

Ratchet Wrench



3/8" Socket



T-50 Torx Bit



Safety Glasses

**HermanMiller**

Part no. 1b6k0d rev K

© 2023 Herman Miller, Inc. Zeeland, Michigan. Printed in the U.S.A.  
™ **HermanMiller**, Everywhere Tables are among the trademarks of Herman Miller, Inc.

Illustrations and specifications are based on the latest product information available at the time of publication. The right is reserved to make changes in design and specifications at any time, without notice, and also to discontinue products.

# Assembly Instructions:

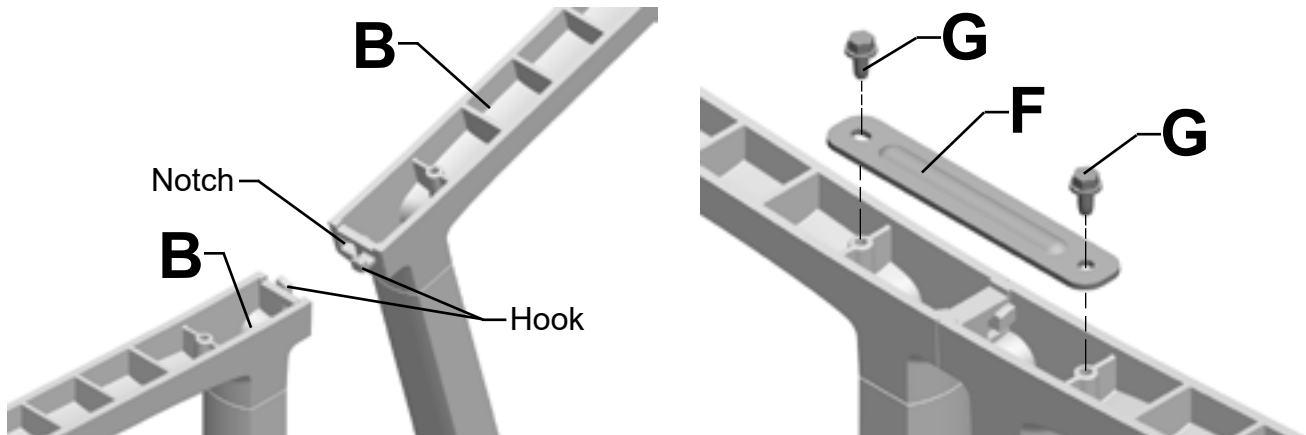

1. If legs have casters, use 1-locking caster and 1-non locking caster per leg assembly.
2. Hold Leg segments (B) at 15 degree angle to one another.
3. Insert Hooks on base of leg segments into notches in adjoining leg segments.
4. Secure Leg segments together with Connection Bracket (F) and 2 Hex Flange Tapping Screws (G). Do not over tighten.

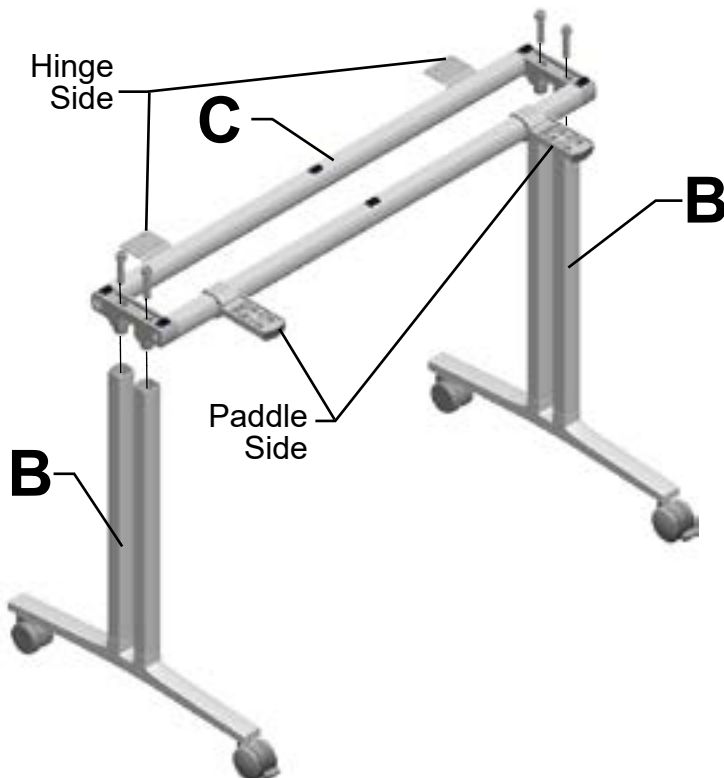

- Note: Locking Casters to be on Paddle side.
5. Remove pre-assembled T-50 Torx head screws from top of the Legs (hold for Assembly).
  6. Insert Leg Assemblies (B) into Cross Member Assembly (C).
  7. Secure Legs to Cross Member with T-50 torx head screws.

**HermanMiller**

Part no. 1b6k0d rev K

© 2023 Herman Miller, Inc. Zeeland, Michigan. Printed in the U.S.A.  
™  Herman Miller, Everywhere Tables are among the trademarks of Herman Miller, Inc.

Illustrations and specifications are based on the latest product information available at the time of publication.  
The right is reserved to make changes in design and specifications at any time, without notice, and also to discontinue products.

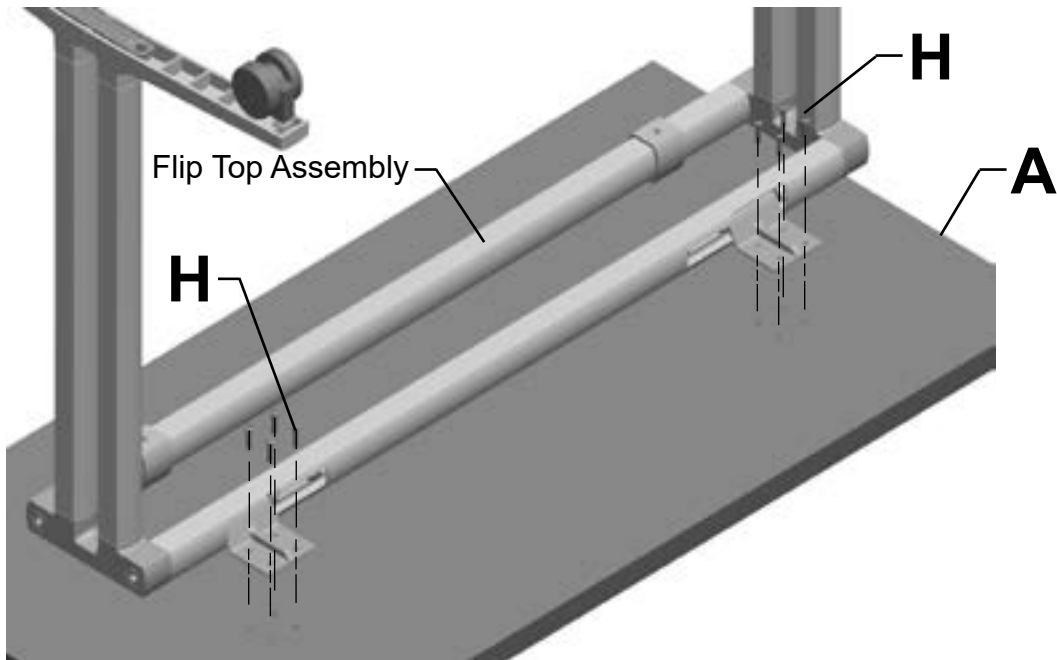

8. Position Flip Top Assembly onto Work Surface (A).
9. Install 8 Pan Head Tapping Screws 3/4" long (H).

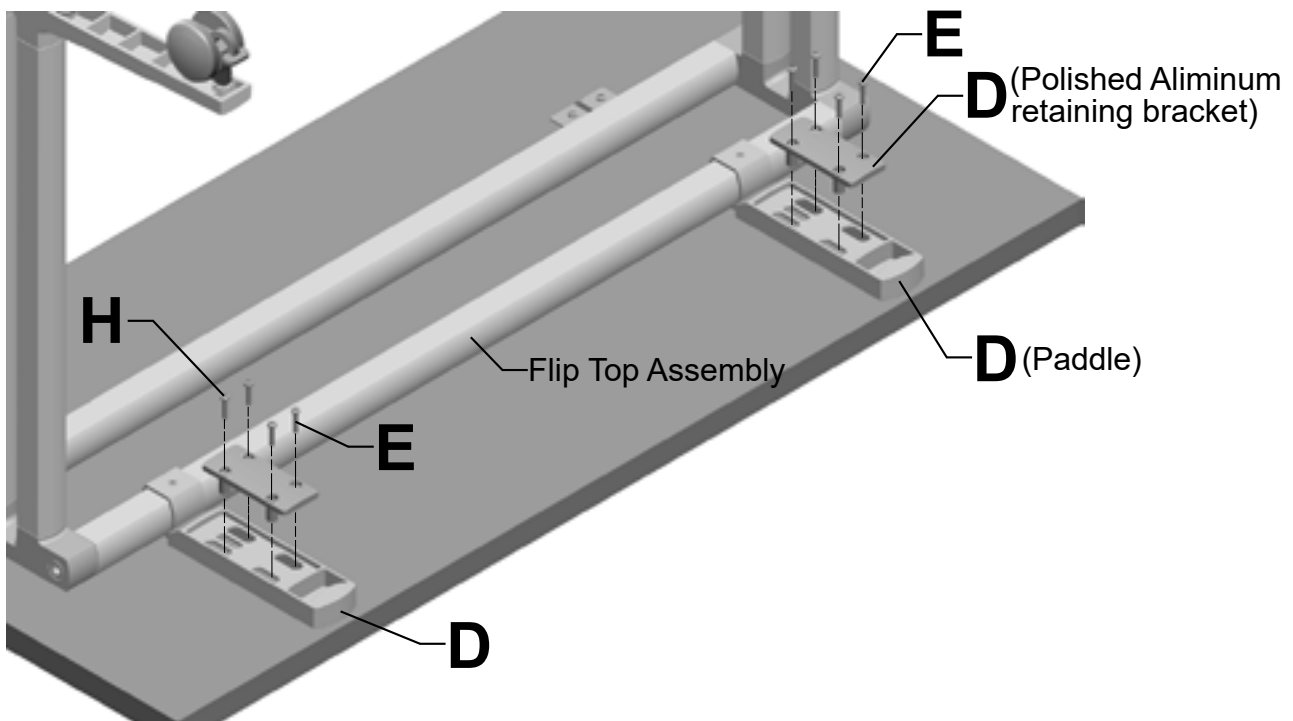

10. Position Paddles (D) up against Collars on Cross Members.
11. Pull back polished Aluminium retaining bracket to Align predrilled pilot holes.
12. Install 8-1 1/2" long Pan Head Tapping screws (E) (part of paddle kit).

## **Disassembly for Recycling:**

---

### **Materials Identification and Segregation:**

Where possible, plastic components are marked with ASTM recycling codes. Use these codes to identify material type for recycling. Non marked components should be treated as mixed plastic. Ferrous metals can be identified using a small magnet for recycling. Non-ferrous metals should be separated and recycled separately.

To disassemble product, reverse steps 12 through 1 and remove the casters.



# Everywhere Tables™ 4 X (X - Option) Installation and Disassembly for Recycling Instructions

## Parts Included:

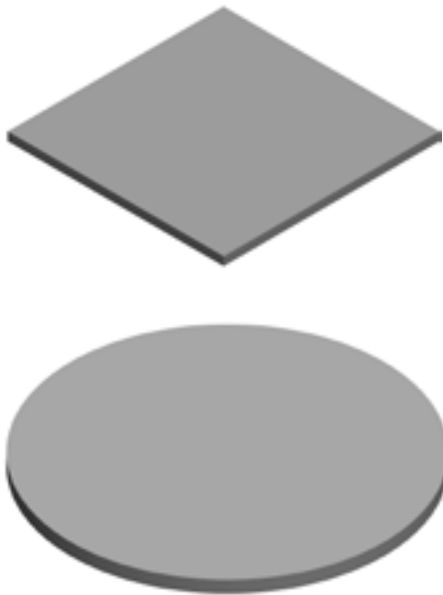

**A** Work Surface Options



**B** T Leg (4)



**C** 4-Way Base Connector



**D** Connection Bracket (2)

**E** Hex Flange Tapping Screw (5)

**F** Pan Head Tapping Screw (32)

## Tools Required:

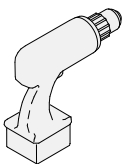

Power Driver

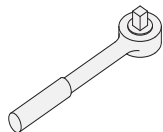

Ratchet Wrench



#2 Phillips Bit



3/8" Socket

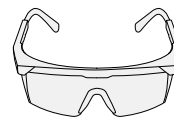

Safety Glasses

**HermanMiller**

Part no. 1b6k0d rev K

© 2023 Herman Miller, Inc. Zeeland, Michigan. Printed in the U.S.A.  
™ Herman Miller, Everywhere Tables are among the trademarks of Herman Miller, Inc.

Illustrations and specifications are based on the latest product information available at the time of publication. The right is reserved to make changes in design and specifications at any time, without notice, and also to discontinue products.

## Assembly Instructions:

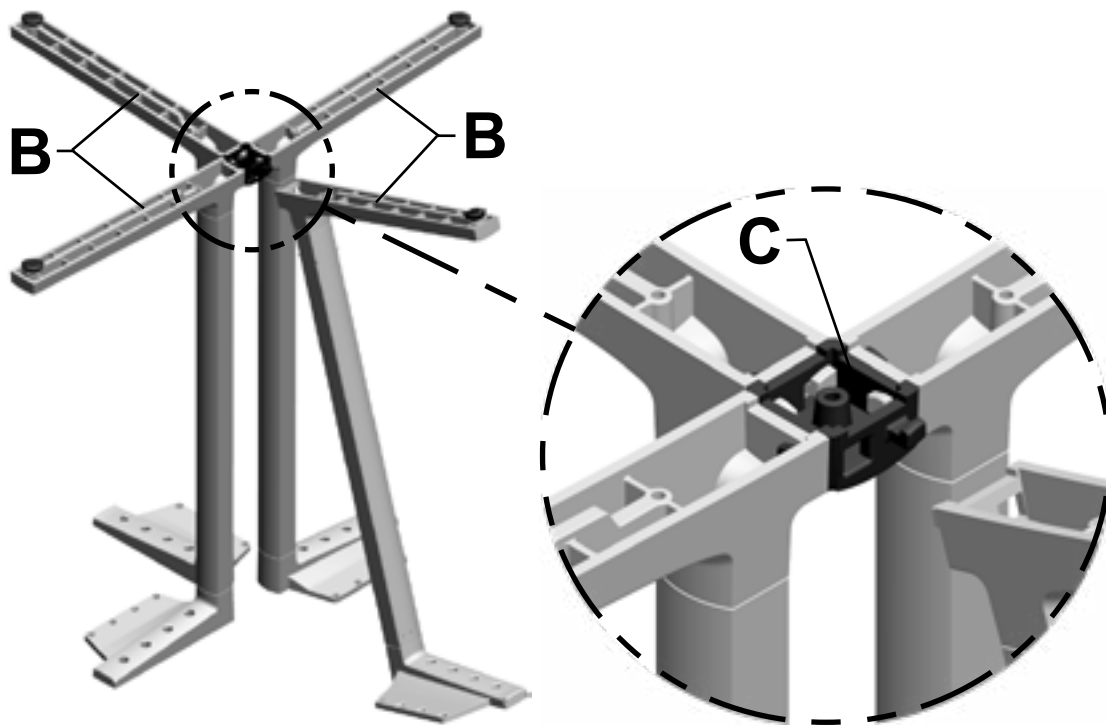

1. Hold Leg segments(B) at 15 degree angle.
2. Interlock Leg Bases onto Base Connector(C).

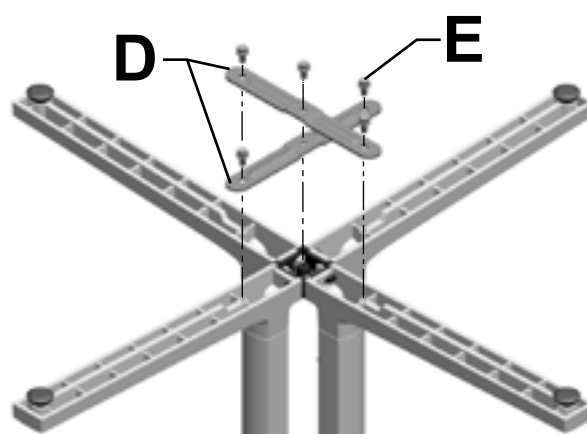
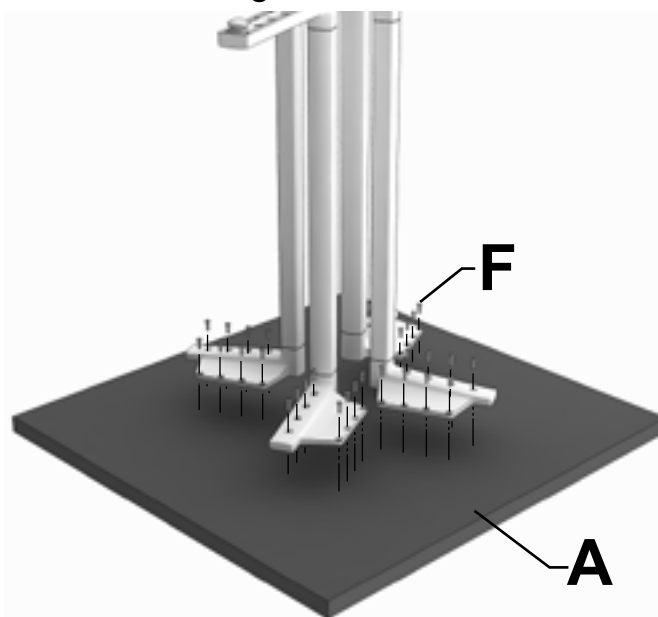

3. Position Leg Assembly onto bottom of Table Top(A).
4. Install 8 screws(F) per Leg.
5. Tie Legs together with 2 Leg Brackets(D) and 5 Hex Flange Screws(E). Do not overtighten.

**HermanMiller**

Part no. 1b6k0d rev K

© 2023 Herman Miller, Inc. Zeeland, Michigan. Printed in the U.S.A.  
™  **HermanMiller**, Everywhere Tables are among the trademarks of Herman Miller, Inc.

Illustrations and specifications are based on the latest product information available at the time of publication.  
The right is reserved to make changes in design and specifications at any time, without notice, and also to discontinue products.

## **Disassembly for Recycling:**

---

### **Materials Identification and Segregation:**

Where possible, plastic components are marked with ASTM recycling codes. Use these codes to identify material type for recycling. Non marked components should be treated as mixed plastic. Ferrous metals can be identified using a small magnet for recycling. Non-ferrous metals should be separated and recycled separately.

To disassemble product, reverse steps 5 through 1.





# Everywhere Tables™ Single Column Base (S) Installation and Disassembly for Recycling Instructions

## Parts Included:

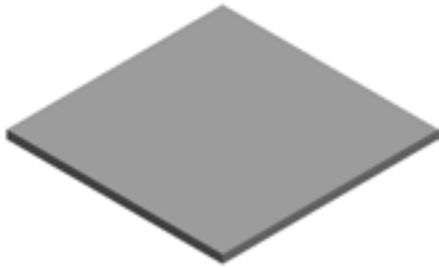

**A** Work Surface Options



**D** Cap



**E** Lock Ring

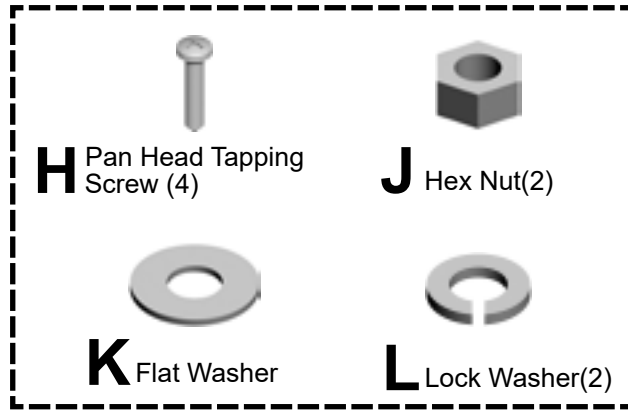

Hardware Pack



**F** Spider



**G** 4-Leg Base



**B** Leg Extrusion



**C** Threaded Rod

## Tools Required:

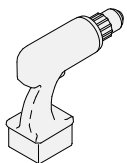

Power Driver

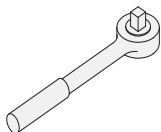

Ratchet Wrench



#2 Phillips Bit



3/8" Socket



T-50 Torx Driver

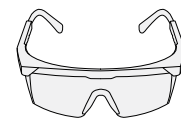

Safety Glasses

**HermanMiller**

Part no. 1b6k0d rev K

© 2023 Herman Miller, Inc. Zeeland, Michigan. Printed in the U.S.A.  
™ Herman Miller, Everywhere Tables are among the trademarks of Herman Miller, Inc.

Illustrations and specifications are based on the latest product information available at the time of publication.  
The right is reserved to make changes in design and specifications at any time, without notice, and also to discontinue products.

## Assembly Instructions:

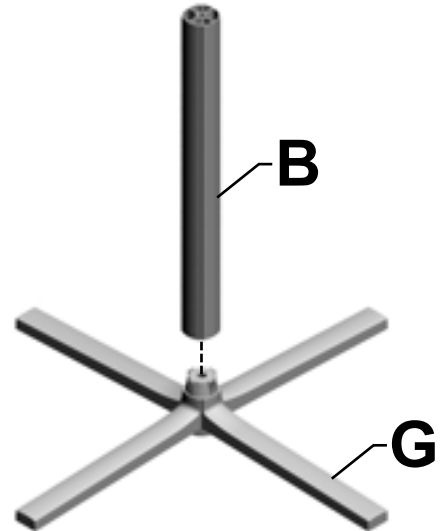
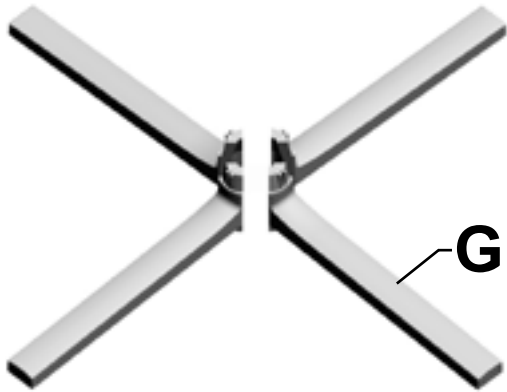

1. Assemble 4-leg base(G) together.
2. 4 Leg Bases(G) fit into Leg Extrusion(B).

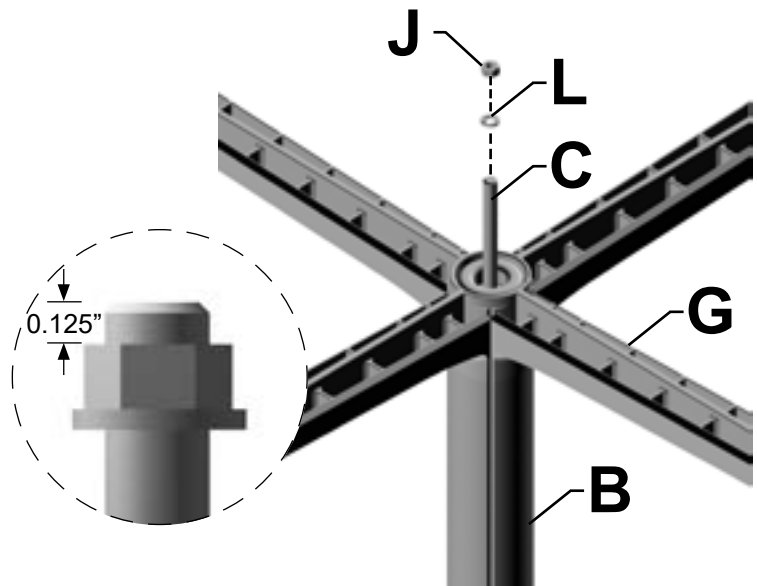
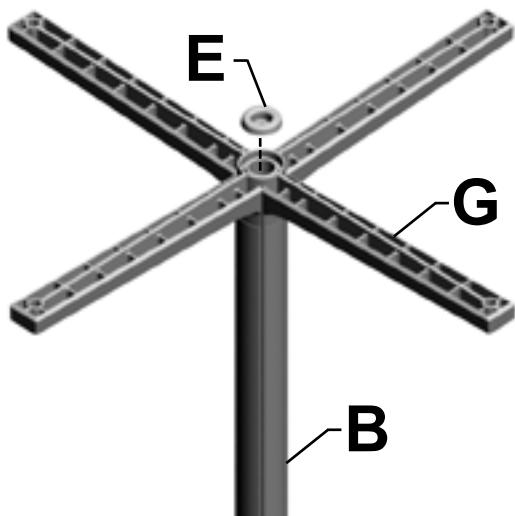

3. Assemble Lock Ring(E) to bottom of Leg base(G).
4. Insert Threaded Rod(C) with Lock Washer(L) & Hex Nut(J) at bottom of Leg Base(G).

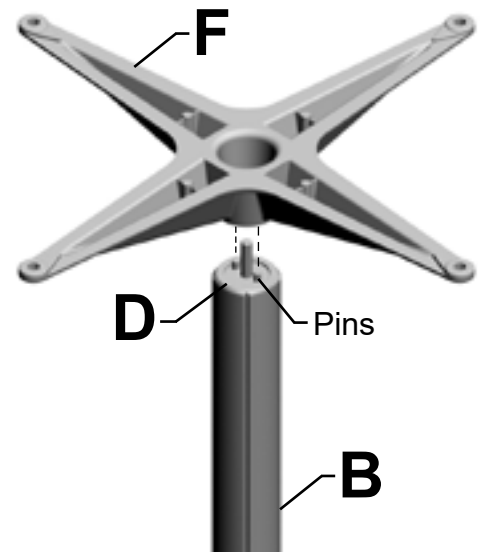
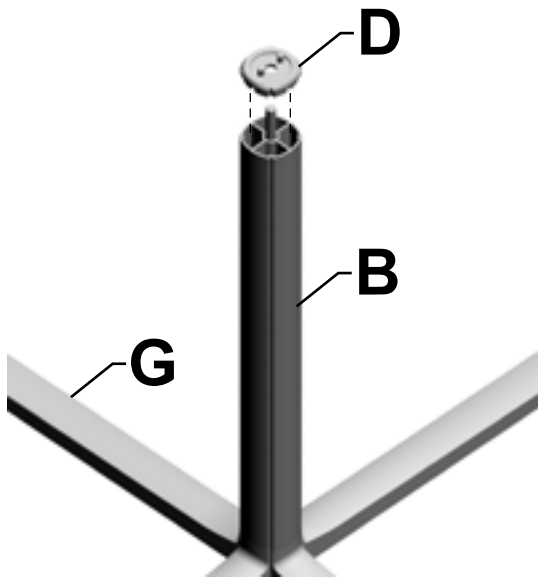

5. Assemble Cap(D) on top of Leg Extrusion(N).
6. Place Spider(F) on top of Cap(D). Make sure pins are in holes in Spider(F).

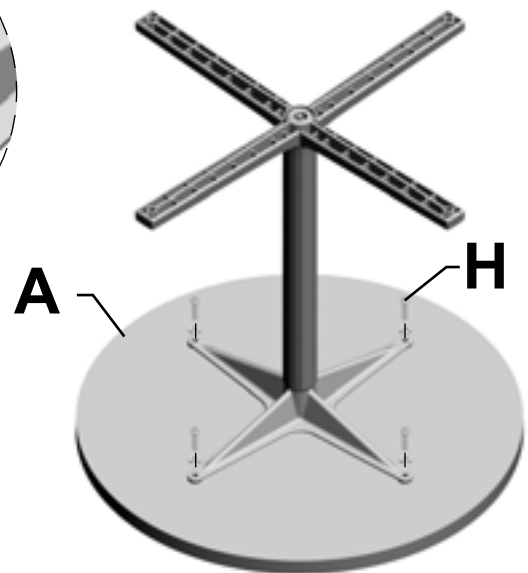
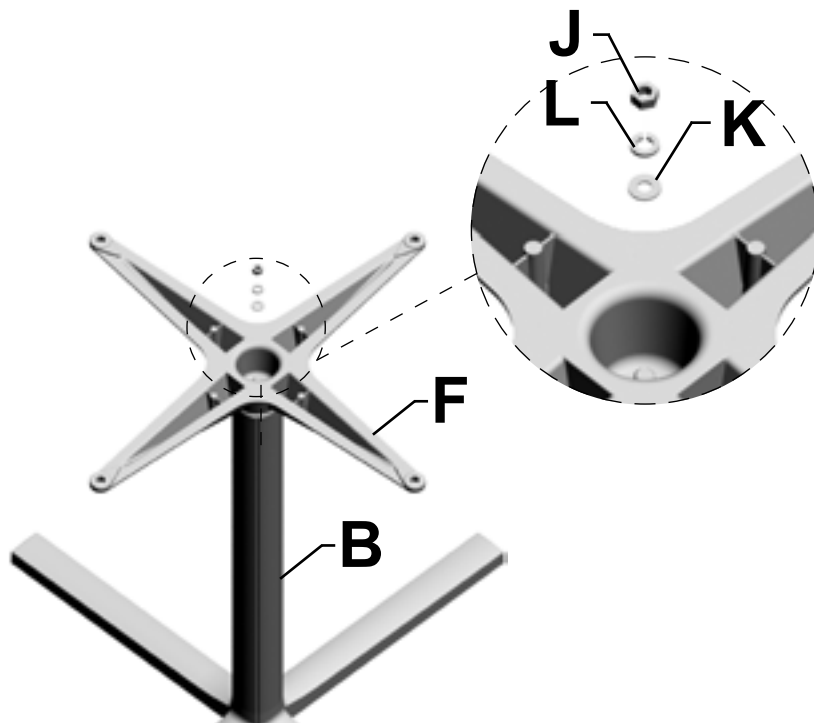

7. Place Flat Washer(K), Lock Washer(L) and Hex Nut(J) to top of Threaded Rod(C). Tighten to a torque specification of 20 ft lbs.
8. Using Pan Head screw(H) assemble Work Surface(A) with Leg Base assembly.

**HermanMiller**

Part no. 1b6k0d rev K

© 2023 Herman Miller, Inc. Zeeland, Michigan. Printed in the U.S.A.  
 TM, ® Herman Miller, Everywhere Tables are among the trademarks of Herman Miller, Inc.

Illustrations and specifications are based on the latest product information available at the time of publication.  
 The right is reserved to make changes in design and specifications at any time, without notice, and also to discontinue products.

## **Disassembly for Recycling:**

---

### **Materials Identification and Segregation:**

Where possible, plastic components are marked with ASTM recycling codes. Use these codes to identify material type for recycling. Non marked components should be treated as mixed plastic. Ferrous metals can be identified using a small magnet for recycling. Non-ferrous metals should be separated and recycled separately.

To disassemble product, reverse steps 8 through 1.



# Everywhere Tables™ Y3 Leg Installation (E-option) Installation and Disassembly for Recycling Instructions

## Parts Included:



**A** Work Surface Options



**B** T Leg (6)



**C** 3-Way Base Connector (2)

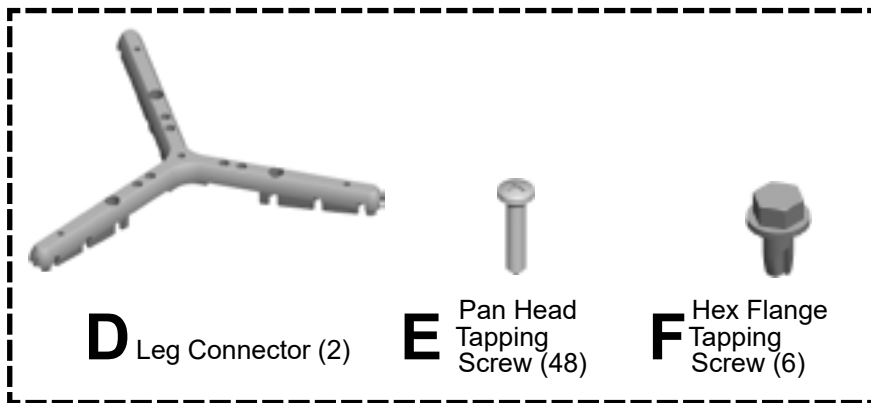

**D** Leg Connector (2)

**E** Pan Head Tapping Screw (48)

**F** Hex Flange Tapping Screw (6)

Hardware Pack Options

## Tools Required:

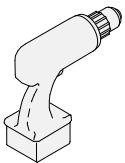

Power Driver

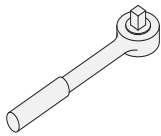

Ratchet Wrench



#2 Phillips Bit



3/8" Socket



Safety Glasses

# Assembly Instructions:

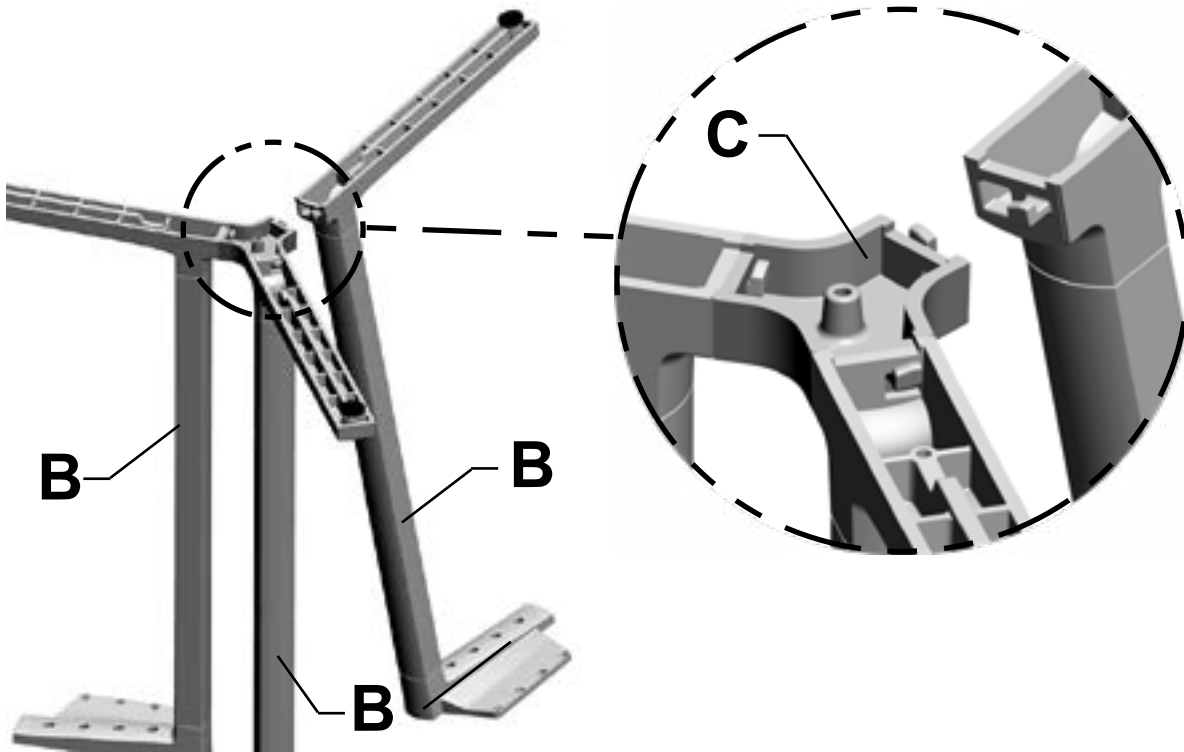

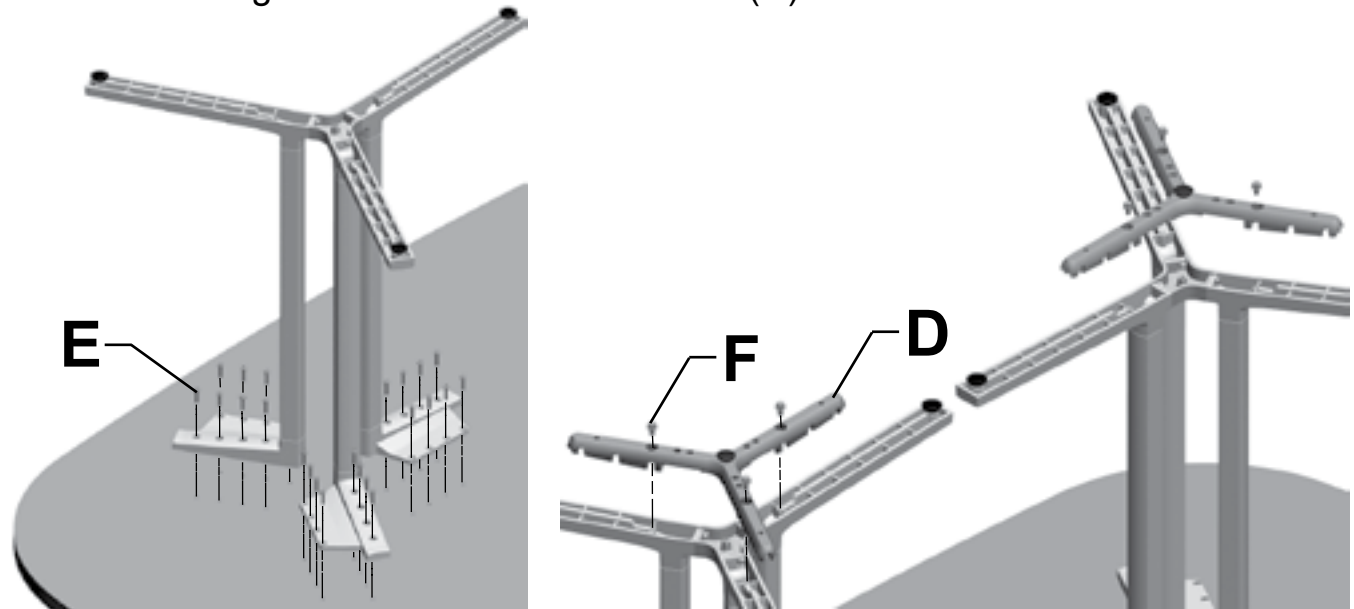

1. Hold Leg segments(B) at 15 degree angle.
2. Interlock Leg Bases onto Base Connector(C).



3. Position Leg Assembly onto bottom side of Work Surface(A)
4. Install 24 Pan Head Tapping Screws(E) per leg assembly.
5. Position Y Brace(D) onto Leg Assemblies.
6. Install 3 Hex Flange Screws(F) per Leg Assembly. Do not overtighten.
7. When in use position, ensure all 8 glides are in contact with the floor.

**HermanMiller**

Part no. 1b6k0d rev K

© 2023 Herman Miller, Inc. Zeeland, Michigan. Printed in the U.S.A.  
™   **HermanMiller**, Everywhere Tables are among the trademarks of Herman Miller, Inc.

Illustrations and specifications are based on the latest product information available at the time of publication.  
The right is reserved to make changes in design and specifications at any time, without notice, and also to discontinue products.

## **Disassembly for Recycling:**

---

### **Materials Identification and Segregation:**

Where possible, plastic components are marked with ASTM recycling codes. Use these codes to identify material type for recycling. Non marked components should be treated as mixed plastic. Ferrous metals can be identified using a small magnet for recycling. Non-ferrous metals should be separated and recycled separately.

To disassemble product, reverse steps 7 through 1.



# Everywhere Tables™ Y2 Leg Installation and Disassembly for Recycling Instructions

## Parts Included:



**A** Work Surface Options



**B** T Leg (4)



**C** 3-Way Base Connector (2)



**D** Leg Spanner (1)

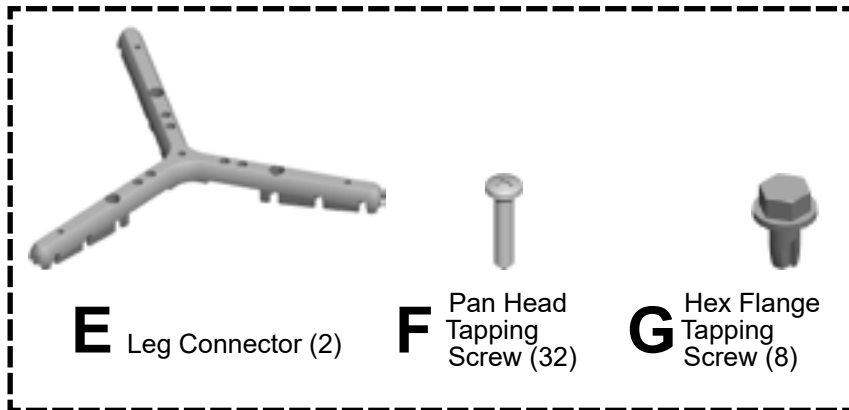

Hardware Pack Options

## Tools Required:

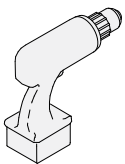

Power Driver

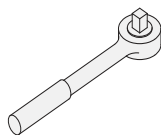

Ratchet Wrench



#2 Phillips Bit



3/8" Socket



Safety Glasses

**HermanMiller**

Part no. 1b6k0d rev K

© 2023 Herman Miller, Inc. Zeeland, Michigan. Printed in the U.S.A.  
™, © Herman Miller, Everywhere Tables are among the trademarks of Herman Miller, Inc.

Illustrations and specifications are based on the latest product information available at the time of publication. The right is reserved to make changes in design and specifications at any time, without notice, and also to discontinue products.



## Assembly Instructions:

1. Hold Leg segments (B) at 15 degree angle.
2. Interlock Leg Bases onto base connector(C).

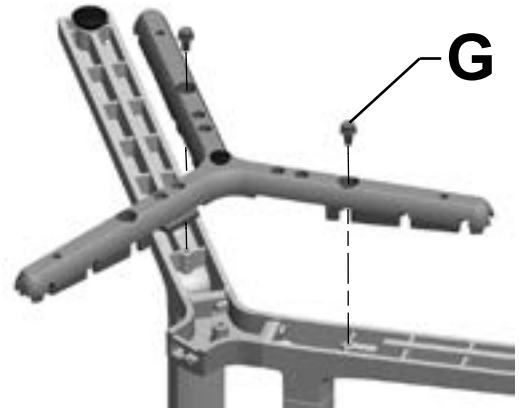
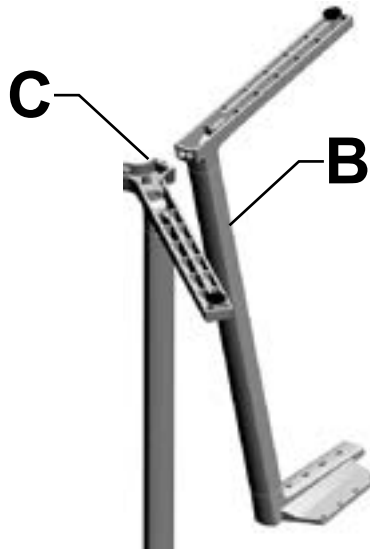

3. Assemble Leg Connectors onto bottom of Leg Assemblies with 2 Hex Flange Tapping Screws(G) per leg.

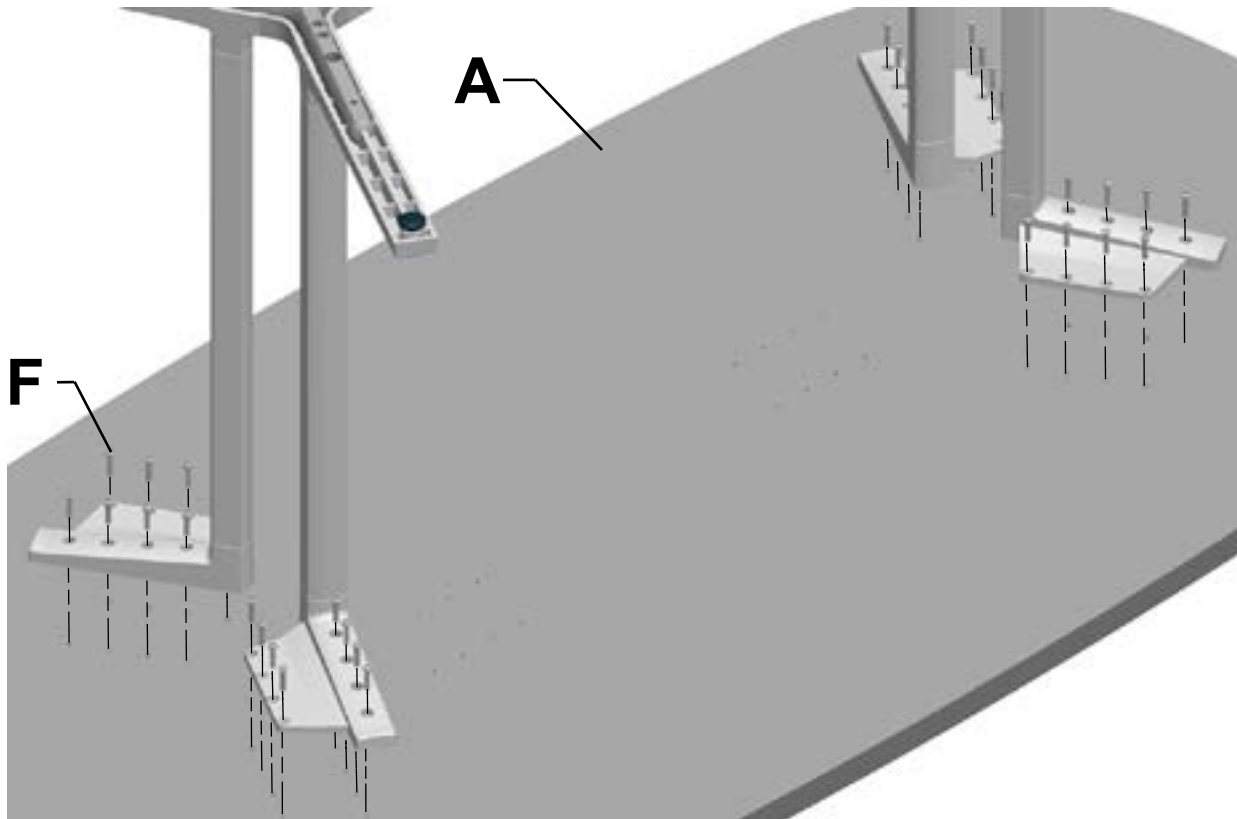

4. Install Leg Assemblies onto Work Surface(A) with 32 Tapping Screws(F).

**HermanMiller**

Part no. 1b6k0d rev K

© 2023 Herman Miller, Inc. Zeeland, Michigan. Printed in the U.S.A.  
™ **HermanMiller**, Everywhere Tables are among the trademarks of Herman Miller, Inc.

Illustrations and specifications are based on the latest product information available at the time of publication.  
The right is reserved to make changes in design and specifications at any time, without notice, and also to discontinue products.

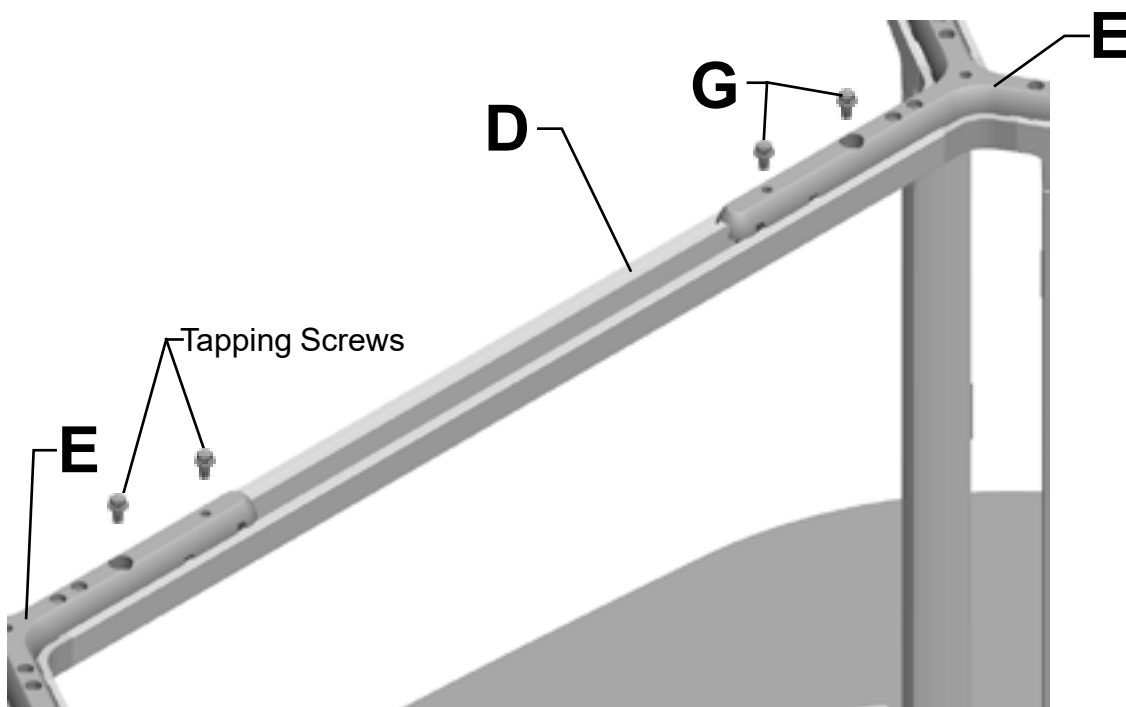

5. Attach spanner (D) to the two leg connectors (E), use 4 Hex flange tapping screws (G). Do not over tighten

## **Disassembly for Recycling:**

### **Materials Identification and Segregation:**

Where possible, plastic components are marked with ASTM recycling codes. Use these codes to identify material type for recycling. Non marked components should be treated as mixed plastic. Ferrous metals can be identified using a small magnet for recycling. Non-ferrous metals should be separated and recycled separately.

To disassemble product, reverse steps 5 through 1.

---

Electrically interconnected tables shall be mechanically connected.

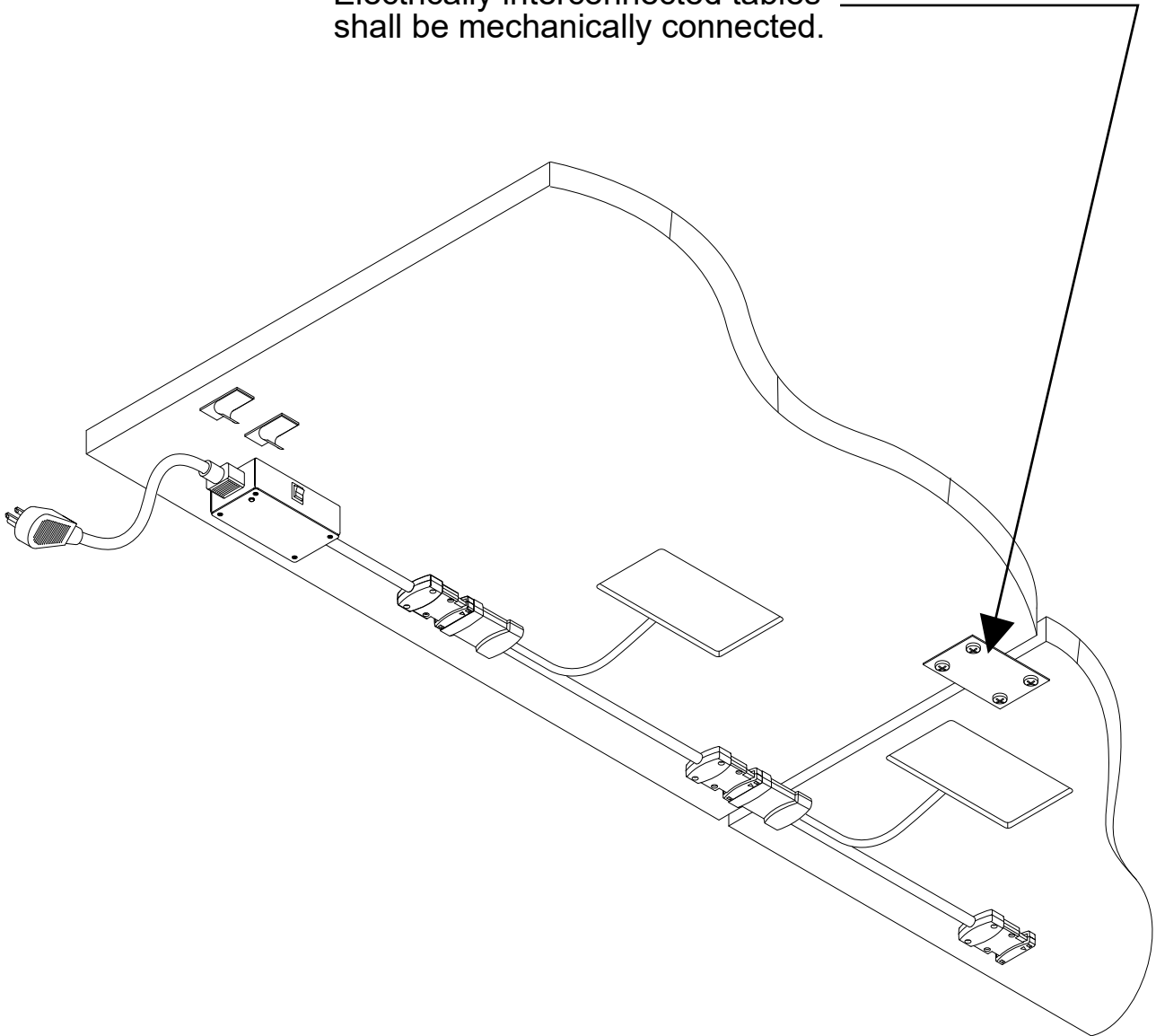



# Everywhere Soft Rectangle - Extended Meeting Table Installation and Disassembly for Recycling Instructions

## Parts Included:



**A** Work Surface (2)

Y2 Leg Option

Post Leg Option

Y Leg Option

**B** Leg kit (2)



**C** 3-Way Base Connector



**D** Stiffener (Post Leg configuration only)



**H** Ganging Plate (2)



**I** Biscuit (4)



**J** Joint Fastener (4)

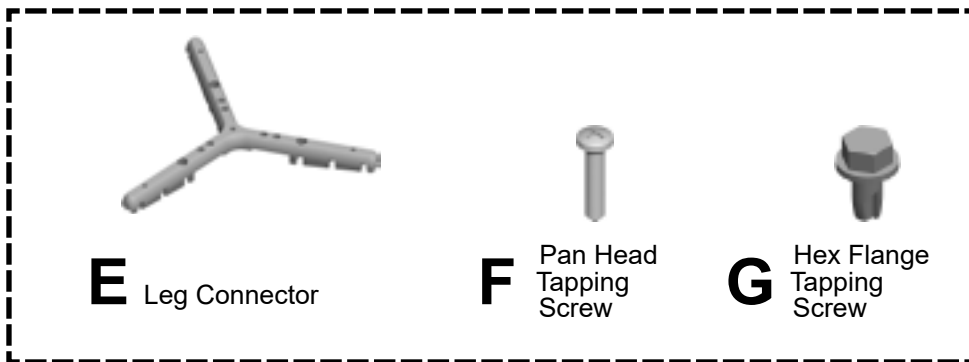

**E** Leg Connector

**F** Pan Head Tapping Screw

**G** Hex Flange Tapping Screw

Hardware Pack Options

## Tools Required:

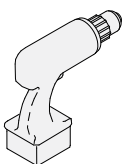

Power Driver

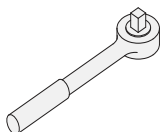

Ratchet Wrench



#2 Phillips Bit



3/8" Socket



Safety Glasses

# Assembly Instructions:

---

Step 1: Lay work surfaces (A) upside down on a soft surface to prevent scratching.

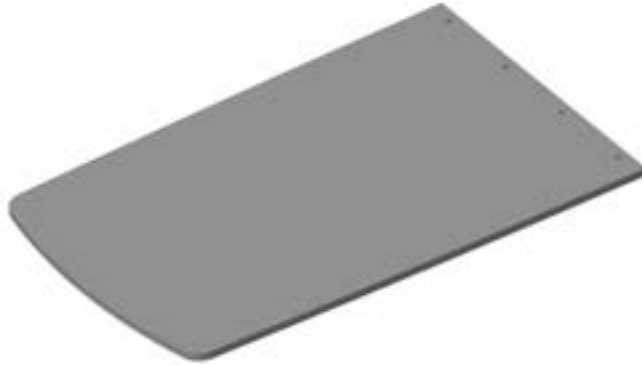

Step 2: Assemble legs using instructions specified in this document. The leg configuration can be determined based on the images below:

## Y2 Leg Option

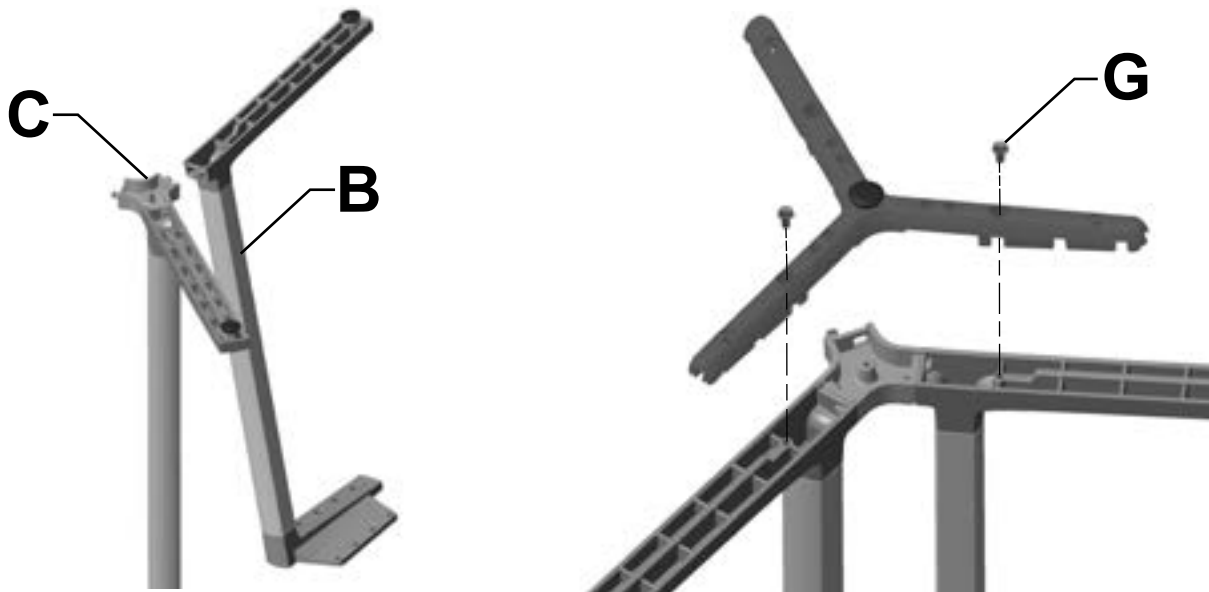

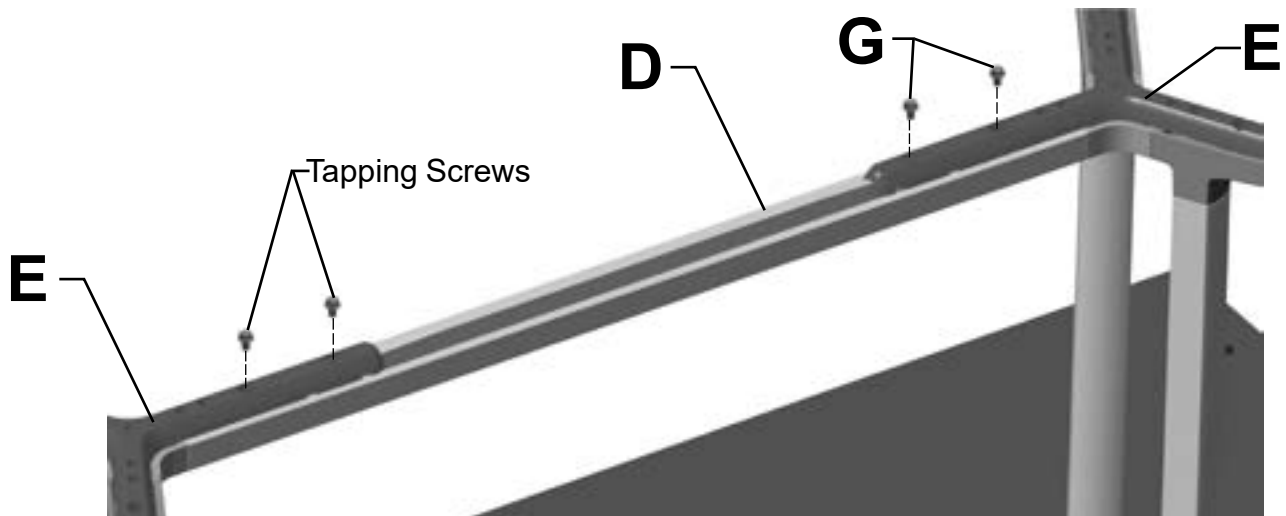
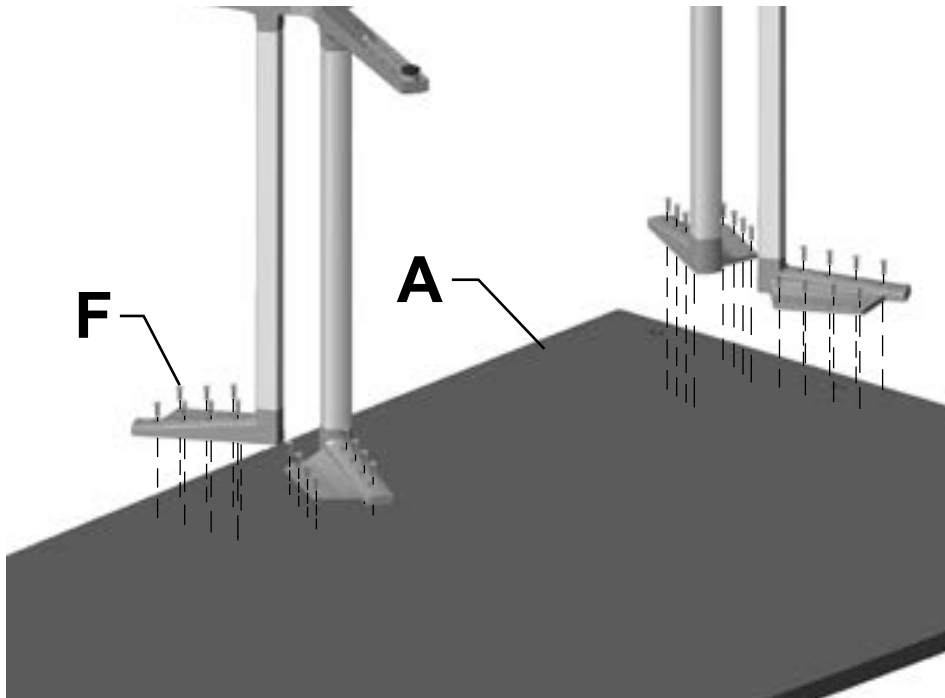

## Y3 Leg Option

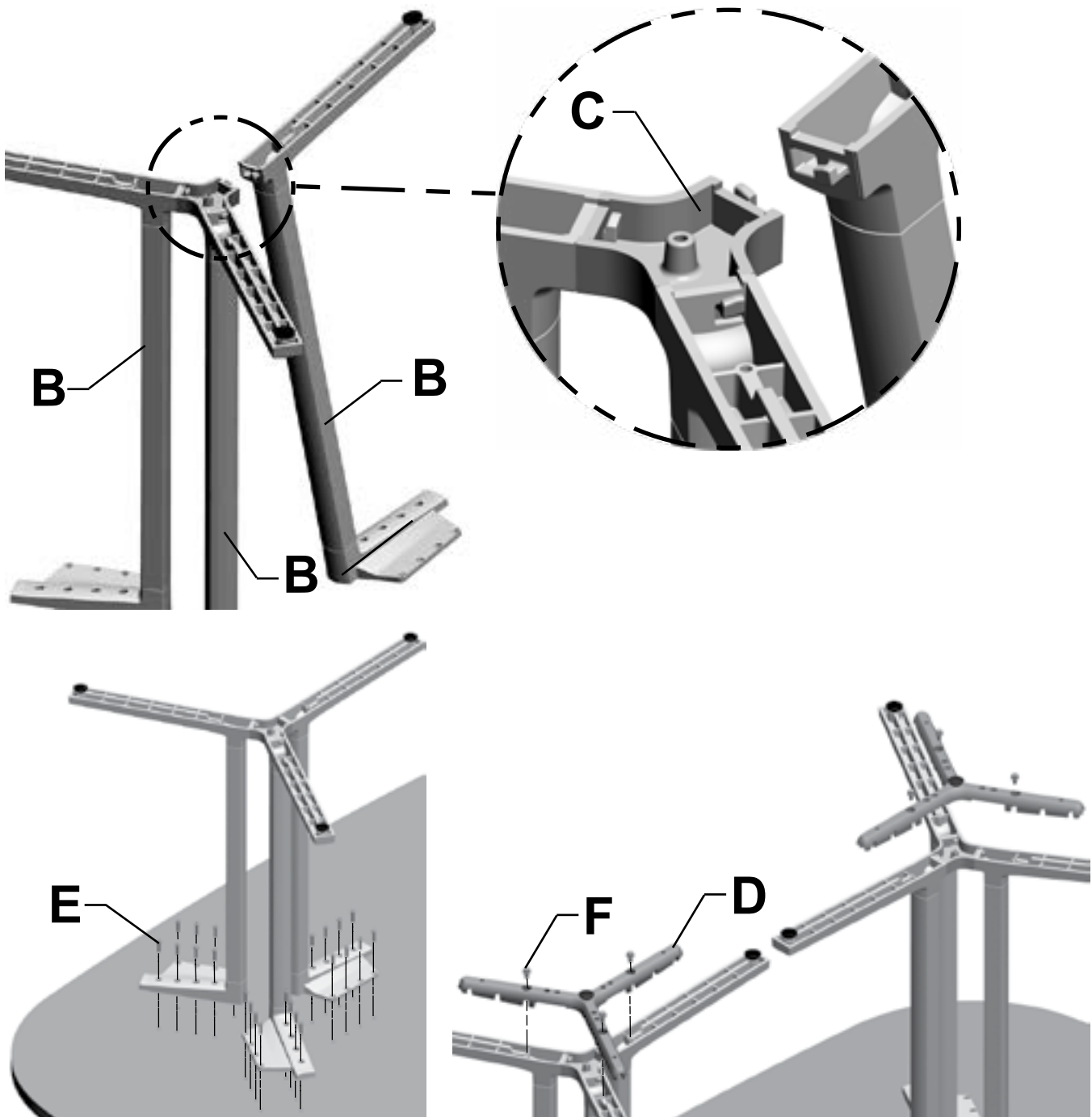

Step 3: Locate the predrilled holes for leg configuration and attach the leg assemblies to the work surface using the included hardware

**HermanMiller**

Part no. 1b6k0d rev K

© 2023 Herman Miller, Inc. Zeeland, Michigan. Printed in the U.S.A.  
™, © Herman Miller, Everywhere Tables are among the trademarks of Herman Miller, Inc.

Illustrations and specifications are based on the latest product information available at the time of publication.  
The right is reserved to make changes in design and specifications at any time, without notice, and also to discontinue products.

---

Step 4: Carefully flip each table onto its feet. Align each joint edge. Attach joint connectors using a small allen wrench to tighten until the joint is gap free. Attach the ganging plate in the pre-drilled holes in the work surface.





## **Disassembly for Recycling:**

---

### **Materials Identification and Segregation:**

Where possible, plastic components are marked with ASTM recycling codes. Use these codes to identify material type for recycling. Non marked components should be treated as mixed plastic. Ferrous metals can be identified using a small magnet for recycling. Non-ferrous metals should be separated and recycled separately.

To disassemble product, reverse steps 4 through 1.